

**REGULAR MEETING
OF
FLORENCE CITY COUNCIL**

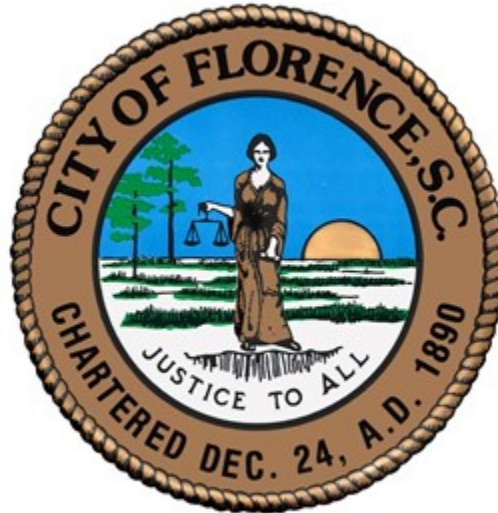

**COUNCIL CHAMBERS
324 W. EVANS STREET
FLORENCE, SOUTH CAROLINA**

**MONDAY
SEPTEMBER 9, 2024
1:00 P.M.**



**REGULAR MEETING OF FLORENCE CITY COUNCIL
MONDAY, SEPTEMBER 9, 2024 – 1:00PM
CITY CENTER – COUNCIL CHAMBERS
324 WEST EVANS STREET
FLORENCE, SOUTH CAROLINA**

I. CALL TO ORDER

II. INVOCATION

Pledge of Allegiance to the American Flag

III. APPROVAL OF MINUTES

August 12, 2024 – Special Meeting
August 12, 2024 – Regular Meeting
August 17, 2024 – Special Meeting

IV. HONORS AND RECONGNITIONS

SERVICE RECOGNITIONS

Larry Richardson – 25 years – Fire Department
Henry Glover – 25 years – Fire Department
Mark Browder – 20 years – Utilities Department

V. ORDINANCES IN POSITION

a. Bill No. 2024-13 – Second Reading

An Ordinance providing for the issuance and sale of combined waterworks and sewerage system revenue bonds of the City of Florence, South Carolina, authorizing the issuance of bond anticipation notes, and other matters relating thereto.

b. Bill No. 2024-14 – Second Reading

An Ordinance to annex and zone RG-3 Phase 2 of Smith's Field subdivision, identified as Florence County Tax Map Parcels 00100-01-337 through 00100-01-380

c. Bill No. 2024-15 – Second Reading

An Ordinance to annex and zone CG the lot at 525 South Ebenezer Road, identified as Florence County Tax Map Number 00074-01-334.

VI. MAYORAL REPORT

VII. COMMITTEE REPORTS

- a. Business Development Committee**
- b. Community Development Committee**
- c. Marketing and Public Relations Committee**
- d. Finance, Audit and Budget Committee**

(Note: Action may be taken during Committee Reports.)

VIII. EXECUTIVE SESSION

- a. For a discussion related to a contractual matter [30-4-70(a)(2)].**

After returning to open session, Council may take action on matters discussed during Executive Session.

IX. ADJOURN



**SPECIAL MEETING OF FLORENCE CITY COUNCIL
MONDAY, AUGUST 12, 2024 – 11:00 A.M.
CITY COUNCIL CHAMBERS
324 WEST EVANS STREET
FLORENCE, SOUTH CAROLINA**

MEMBERS PRESENT

Mayor Teresa Myers Ervin, Mayor Pro Tempore George Jebaily, Councilwoman Lethonia Barnes, Councilman Chaquez T. McCall, Councilman J. Lawrence Smith, II and Councilwoman LaShonda NeSmith-Jackson

MEMBERS ABSENT

Councilman Bryan A. Braddock

ALSO PRESENT

Mr. Scotty Davis, City Manager; Mrs. Casey Moore, Municipal Clerk; Mr. Michael Hemingway, Director of Utility Planning and Economic Development; Mr. Benjamin T. Zeigler, City Attorney

MEDIA PRESENT

No media was present for the meeting.

Notices of this regular meeting of City Council were provided to the media and individuals requesting a copy of the agenda informing them of the date, location and time of the meeting.

CALL TO ORDER

Mayor Ervin called the August 12, 2024 special meeting of Florence City Council to order at 11:09 a.m.

INVOCATION

Mayor Ervin gave the invocation for the meeting. The pledge of allegiance to the American Flag followed the invocation.

EXECUTIVE SESSION

Mayor Ervin said Council will be entering into Executive session to receive legal advice regarding the PFAS lawsuit.

Councilman McCall made a motion to enter into Executive Session and Councilwoman NeSmith-Jackson seconded the motion. Council voted 6-0 to enter into Executive Session at 11:10 a.m.

Council resumed open session at 12:30 p.m. No action was taken.

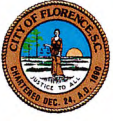

**FLORENCE CITY COUNCIL
SPECIAL MEETING – AUGUST 12, 2024**

ADJOURN

Without objection, the August 12, 2024 special meeting of City Council was adjourned at 12:30 p.m.

Dated this 9th day of September 2024.

Casey C. Moore, Municipal Clerk

Teresa Myers Ervin, Mayor



**REGULAR MEETING OF FLORENCE CITY COUNCIL
MONDAY, AUGUST 12, 2024 – 1:00 P.M.
CITY CENTER – COUNCIL CHAMBERS
324 WEST EVANS STREET
FLORENCE, SOUTH CAROLINA**

MEMBERS PRESENT

Mayor Teresa Myers Ervin, Mayor Pro Tempore George Jebaily, Councilwoman Lethonia Barnes, Councilman Chaquez T. McCall, Councilwoman LaShonda NeSmith-Jackson and Councilman J. Lawrence Smith, II

MEMBERS ABSENT

Councilman Bryan A. Braddock

ALSO PRESENT

Mr. Scotty Davis, City Manager; Mr. Benjamin T. Zeigler, City Attorney; Mrs. Casey Moore, Municipal Clerk; Mr. Clint Moore, Assistant City Manager of Development; Chief Allen Heidler, Florence Police Department; Chief Shannon Tanner, Florence Fire Department; Mr. Michael Hemingway, Director of Utility Planning and Economic Development; Mr. Jerry Dudley, Director of Planning; Mrs. Victoria Nash, Director of Parks, Recreation, and Sports Tourism; Mrs. Amanda Pope, Director of Marketing/Communications and Municipal Services; Mrs. Jennifer Krawiec, Director of Human Resources; Mr. Adam Swindler, Director of Public Works; Mr. Joshua Whittington, Director of Utilities; Mr. Glenn Bodenheimer, Interim Finance Director and Ms. Patrice Rankin, Administrative Coordinator

MEDIA PRESENT

Mr. Seth Taylor with the Post and Courier and Ms. Audra Grant with the Florence Morning News were present for the meeting.

Notices of this regular meeting of City Council were provided to the media and individuals requesting a copy of the agenda informing them of the date, location, and time of the meeting.

CALL TO ORDER

Mayor Ervin called the August 12, 2024 regular meeting of Florence City Council to order at 1:01pm.

INVOCATION

Mayor Ervin gave the invocation for the meeting. The pledge of allegiance to the American Flag followed the invocation.

APPROVAL OF MINUTES

Councilwoman NeSmith-Jackson made a motion to adopt the minutes of the July 8, 2024 Regular Meeting and Councilwoman Barnes seconded the motion. The minutes were unanimously (6-0) adopted.



ADDENDUM TO THE AGENDA:

EXECUTIVE SESSION

Action from Executive Session from the special called meeting held at 11:00am on August 12, 2024 to receive legal advice regarding the PFAS lawsuit [30-4-70(a)(2)].

Councilman McCall made a motion to add this item to August 12, 2024 meeting agenda and Councilwoman NeSmith-Jackson seconded the motion. This item was added to the agenda by unanimous vote (6-0).

SERVICE RECOGNITIONS

Mr. Shannon Tanner, Fire Chief, presented Kevin Coleman with a certificate of recognition for 25 years of service with the Florence Fire Department.

Mr. Allen Heidler, Police Chief, presented Christopher Walters with a certificate of recognition for 25 years of service with the Florence Police Department.

Mr. Scotty Davis, City Manager, presented James Moore with a certificate of recognition for 10 years of service with the City of Florence.

APPEARANCES BEFORE COUNCIL

Charlie Barrineau, Field Services Manager – Municipal Association of S.C.

Mr. Charlie Barrineau presented the Municipal Achievement Award in the Economic Development category for Sports Tourism to the City of Florence. Forty municipalities applied for this award and the City of Florence was selected as the winner. Mr. Barrineau said the City of Florence has received this award five times.

Don Strickland, Executive Director – PDRTA

Mr. Don Strickland appeared before Council to provide an update on the Pee Dee Regional Transportation Authority (PDRTA). PDRTA is celebrating its 50th anniversary and services six counties in the Pee Dee region. He spoke on the need for expansion of service hours, growth and connectivity and said they are working with the FLATS Committee to complete a transit study. PDRTA has partnered with local healthcare providers, educational institutions and workforce to provide transportation routes.

Mayor Ervin acknowledged the partnership between PDRTA and the City of Florence to provide transportation from the local schools to the Barnes Street Activity Center.

Connie Waters

Ms. Connie Waters appeared before Council to speak on dog parks in the City. She introduced several officers with the Florence County Sheriff's Office along with a law enforcement canine. One of the officers announced that the Florence County Violent Crimes Task Force would be traveling to California to receive a certification for Street Crimes Unit of the Year. Ms. Waters said that she was pleased to know that the city has 3 dog parks, but each existing city park is large enough to construct more dog parks. She



**FLORENCE CITY COUNCIL
REGULAR MEETING – AUGUST 12, 2024**

shared her vision of the city having a dog park that would honor fallen military and law enforcement dogs.

Janie Behr

Ms. Janie Behr appeared before Council to speak on the recent dog attack and the control of dangerous dogs, specifically pit-bull dogs. She shared an encounter that she had with a pit bull but was able to get away unharmed. Ms. Behr acknowledged the dog attack that claimed the life of Ms. Karen Nelson, as well as a pit bull attack with a minor in Florence County. Ms. Behr shared statistics regarding pit bull bans in the United Kingdom and asked Council to consider banning dangerous pit bull dogs in the City of Florence.

Jayne Boswell

Ms. Jayne Boswell appeared before Council to speak on spay and neuter ordinances and a spay and neuter clinic. The Humane Society was established to care for homeless animals in the community. There is currently a crisis with animals and there are not enough adoptions to decrease the number of animals in shelters. Ms. Boswell shared the idea of a regional low cost spay and neuter clinic to assist with lowering the pet population in the community. Best Friends Animal Society is currently offering free spay and neuter of bully breeds and would like to bring the service to the City of Florence. Ms. Boswell said the Florence Humane Society is working on a financial plan to assist with the spay and neuter and clinic.

INTRODUCTION OF ORDINANCES

Bill No. 2024-13- First Reading

An Ordinance providing for the issuance and sale of combined waterworks and sewerage system revenue bonds of the City of Florence, South Carolina, and other matters relating thereto.

Councilwoman Barnes made a motion to pass Bill No. 2024-13 on first reading and Councilwoman NeSmith-Jackson seconded the motion.

Mr. Davis said this bill is in reference to water and sewer revenue bonds of up to \$270 million. These funds will allow the City to secure the funding necessary for the expansion of the city's Surface Water Treatment Plant and to rehabilitate and upgrade the Jeffries Creek Sewer Interceptor. Mr. Davis introduced Ms. Amy Vitner, Managing Director with First Tryon Advisors, to present the financing plan to Council. He said this information was previously presented to the Finance, Audit and Budget Committee.

Ms. Vitner presented background information regarding the upcoming bond sale. In 2023, the city issued \$33.5 million to fund a portion of the \$537 million, 10-year water and sewer Capital Improvement Plan. The ten-year rate structure for utilities was also amended and adopted to accommodate the level of borrowing for the costs of the projects. Since 2023, the city's project costs have increased to \$676,231,000 due to increased cost estimates as well as additional projects. Ms. Vitner said the adopted rate increases should be adequate to support the additional costs in the short term. The city may need to consider additional rate increases once timing is determined for longer term projects. Projects included in Phase II are the Surface Water Treatment Plant Expansion, the Jeffries Creek Sewer Interceptor and the PFAS project. The project costs for Phase II have increased by \$77 million for a total cost of \$305 million. Other sources of funding have been identified to include \$15 million in anticipated grant funding and a \$24 million SRF Loan. The balance of \$266 million is expected to be financed with the revenue bond. In addition to the Phase II costs increases, the Wastewater Management Facility Expansion project



FLORENCE CITY COUNCIL REGULAR MEETING – AUGUST 12, 2024

has grown from \$180 million to \$250 million, but debt for this project is not anticipated to be issued until fiscal year 2029. Debt service remains in line with last year until 2030; however, starting in 2030, when the debt payments for the Wastewater Management Expansion commence, the city will likely need to identify additional revenues.

Councilwoman NeSmith-Jackson asked for the start date of the Phase II projects. Ms. Vitner said the engineering and design phases are almost complete, so construction could start later this year. Mr. Michael Hemingway, Director of Utility Planning and Economic Development, confirmed the construction for the surface water expansion project will start in November and will take five years to complete. The Jeffries Creek Sewer Interceptor design phase will be complete in March 2025 and construction will begin sometime after spring 2025.

Councilwoman NeSmith-Jackson asked if the city anticipates any additional rate increases. Mr. Hemingway said additional increases could occur if escalated costs are received from contractors during the bid process. Councilwoman NeSmith-Jackson asked what the next steps are if escalated costs do occur. Mr. Hemingway said the city is still seeking other revenue opportunities such as grants to assist in funding these projects.

Councilman McCall asked Mr. Davis to clarify if this bond will be used to fund additions to the city's water and sewage system. Mr. Davis responded yes. Councilman McCall asked if this would cover any deferred maintenance issues and Mr. Davis responded no. These projects will be to upgrade the city's system so that the city can continue to address the demand on the system. Mr. Davis also spoke on maintenance of the utility system. AECOM presented an assessment at last month's Council meeting that indicated \$37.2 million in repairs and improvements to the city's utility system. City staff is working diligently on securing grant funding and existing dollars to cover the cost of repairs and improvements. The \$37.2 million in repairs and improvements will not come out of this bond.

Pro tem Jebaily said that the city is under DHEC order to address the sewer line that runs through Jeffries Creek. The Jeffries Creek Interceptor will address sewage issues that has been ongoing for years and will. Mr. Davis said this project will help to address the sewage issues that the community has been dealing with for a number of years.

Councilwoman Barnes asked Mr. Davis to explain the process of flushing the water lines to resolve the discolored water issue. Mr. Davis said the discolored water is due to the high iron content in the water. The city has a dual water system consisting of groundwater wells and surface water. The water from the wells contains a high amount of iron and sometimes the iron will coat the inside of the pipes. The city uses filtration systems and flushing mechanisms to resolve the discolored water. Many of the issues with discolored water will be addressed with the \$37.2 million in repairs and improvements to the system.

Mayor Ervin spoke on the importance of looping the water lines in the system. Much of the system consists of dead-end lines causing water to sit and collect iron sediment. Looped lines help prevent discolored water with the continuous circulation of water through the pipes.

Council voted unanimously (6-0) in favor of the motion. Bill No. 2024-13 was passed on first reading.



**FLORENCE CITY COUNCIL
REGULAR MEETING – AUGUST 12, 2024**

Bill No. 2024-14 – First Reading

An Ordinance to annex and zone RG-3 Phase 2 of Smith’s Field subdivision, identified as Florence County Tax Map Parcels 00100-01-337 through 00100-01-380.

Councilman Smith a motion to pass Bill No. 2024-14 on first reading and Councilwoman Barnes seconded the motion.

Mr. Jerry Dudley, Planning Director, said this request is consistent with the development agreement that requires the developer to annex into the city as they finish the phases of development. The applicant is requesting to zone Residential General-3 (RG-3) and the development has been subdivided into forty-five lots. Planning Commission voted unanimously to recommend the zoning request.

Council voted unanimously (6-0) in favor of the motion. Bill No. 2024-14 was passed on first reading.

Bill No. 2024-15- First Reading

An Ordinance to annex and zone CG the lot at 525 South Ebenezer Road, identified as Florence County Tax Map Number 00074-01-334.

Councilwoman Barnes made a motion to pass Bill No. 2024-15 on first reading and Pro tem Jebaily seconded the motion.

Mr. Jerry Dudley, Planning Director, said this request is for the KJ’s Market located at the corner of Ebenezer Road and Pine Needles Road. The applicant is requesting Commercial General zoning, which is consistent with the land use and the lots in the vicinity. Planning Commission voted unanimously to recommend the zoning request.

Pro tem Jebaily asked if the same developer owns the adjacent parcels. Mr. Dudley said he wasn’t sure of the owner of the adjacent parcels but could find out who the owner is.

Councilwoman NeSmith-Jackson inquired on the continuity for annexation of this property. Mr. Dudley said continuity is provided across Pine Needles Road from The Grove development. Councilwoman NeSmith-Jackson asked if city staff knew the applicant’s reason for requesting annexation. Mr. Dudley said the applicant is requesting city services, primarily police protection. Councilwoman NeSmith-Jackson asked how long has the KJ’s Market been opened for business. Mr. Dudley said it has been in business for some years.

Mayor Ervin said this KJ’s Market was recently remodeled, as well as the KJ’s Market located on Pamplico Highway.

Council voted unanimously (6-0) in favor of the motion. Bill No. 2024-15 was passed.

INTRODUCTION OF RESOLUTIONS

Resolution No. 2024-31

A Resolution to proclaim August 4-10, 2024 as National Health Center Week in the City of Florence.

Councilwoman NeSmith-Jackson made a motion to pass Resolution No. 2024-31 and Councilman Smith seconded the motion.



**FLORENCE CITY COUNCIL
REGULAR MEETING – AUGUST 12, 2024**

Councilwoman NeSmith-Jackson and Mayor Ervin presented the Resolution to Nicole Echols, Director of External Affairs for Hope Health.

Council voted unanimously (6-0) in favor of the motion. Resolution No. 2024-31 was passed.

Resolution No. 2024-32

A Resolution to recognize August as Black Business Month in the City of Florence.

Councilwoman NeSmith-Jackson made a motion to pass Resolution No. 2024-32 and Councilman McCall seconded the motion.

Councilwoman NeSmith-Jackson presented the Resolution to Les Echols, Director of Community and Minority Enterprise for the Greater Florence Chamber of Commerce.

Council voted unanimously (6-0) in favor of the motion. Resolution No. 2024-32 was passed.

Resolution No. 2024-33

A Resolution of Recognition for Ashley Briggs.

Councilwoman NeSmith-Jackson made a motion to pass Resolution No. 2024-33 and Councilman Smith seconded the motion.

Councilman Smith presented the Resolution to Ashley Briggs.

Council voted unanimously (6-0) in favor of the motion. Resolution No. 2024-33 was passed.

Resolution No. 2024-34

A Resolution certifying buildings as an abandoned building site pursuant to the South Carolina Abandoned Buildings Revitalization Act, Title 12, Chapter 67 Section 12-67-100 of the South Carolina Code of Laws, as amended regarding the property located at 161 N. Coit Street, Florence, South Carolina, Florence County Tax Map Parcel 90073-15-029.

Pro tem Jebaily made a motion to pass Resolution No. 2024-34 and Councilman McCall seconded the motion.

Mr. Clint Moore, Assistant City Manager of Development, said this resolution will certify the abandoned buildings located on North Coit Street that are in association with the Urban Square project. The contractors previously submitted their letter of intent to the state and Council passing this Resolution will complete the documentation process.

Council voted unanimously (6-0) in favor of the motion. Resolution No. 2024-34 was passed.

Resolution No. 2024-35

A Resolution of City Council approving Downtown Redevelopment Grants for First Quarter, FY25.

Mayor Ervin said this item will be discussed in Executive Session. Having no objection, this item will be discussed in Executive Session.



REPORTS TO COUNCIL

Department of Environmental Services

Mr. Scotty Davis, City Manager, said the city wanted to give clarity and transparency regarding the water system. He introduced Mr. David Thompson, drinking water team lead with the Department of Environmental Services (DES), to provide an update regarding the water system.

Mr. David Thompson said the city operates the water system for Florence, as well as the Town of Timmonsville. The city's last inspection was satisfactory and these inspections are completed out of the Columbia Department of Environmental Services. The Department of Environmental Services is not required to give prior notification for inspections, but a courtesy call may be offered the day before to make sure the proper operators are present during the inspection. A Department of Environment Services inspection will consist of a review of paperwork, equipment operations, maintenance of equipment, cleanliness and security of the facilities and ensure operator requirements are met. They will also complete a review of the annual audit for water loss percentage and review the Consumer Confidence report. Mr. Thompson also said DES works closely with the city regarding complaints received of discolored water and concluded by saying the city is doing a great job providing water to the customers of Florence.

Councilwoman Barnes asked for the tiers of the Department of Environment Services grading system. Mr. Thompson said the facilities can receive a satisfactory, needs improvement or unsatisfactory rating.

MAYORAL REPORT

Mayor Ervin thanked city staff for ensuring that the citizens of Florence have potable water. She also thanked city staff for their emergency preparedness efforts during Tropical Storm Debby, as well as the citizens who helped to clean storm drains. The City of Florence received a Municipal Achievement Award from the Municipal Association of South Carolina at the annual meeting in Greenville, SC. The 2nd Annual Pee Dee Youth Day Initiative event was well attended and was a success.

COMMITTEE REPORTS

Business Development Committee, Chaired by Pro tem Jebaily

Pro tem Jebaily said the committee discussed feedback received from the public meeting regarding the Lucas Street Corridor. The committee also received updates regarding infrastructure and trail projects.

Community Development Committee, Chaired by Councilwoman Barnes

Councilwoman Barnes said the committee discussed efforts to unify the community. The committee is continuing to work on the five points of a crime plan and received information on railroad quiet zones.

Marketing and Public Relations Committee, Chaired by Councilwoman NeSmith-Jackson

Councilwoman NeSmith-Jackson encouraged residents to sign up to receive notifications from "Cy." The fall session of City University will be held on September 16th through October 28th. The deadline to apply for the fall session is September 8th. Councilwoman NeSmith-Jackson acknowledged that August is also National Dog Month and Women's Equality Day is August 26th. The committee will continue to work on awareness campaigns.



**FLORENCE CITY COUNCIL
REGULAR MEETING – AUGUST 12, 2024**

Mayor Ervin said that she has met with Florence 1 Schools to discuss hosting a Youth City University session.

Finance, Audit and Budget Committee, Chaired by Councilman McCall

Councilman McCall said the committee received a presentation from First Tryon Advisors on the water and sewer bonds. The committee also reviewed the monthly financial reports for June 2024.

EXECUTIVE SESSION

Mayor Ervin said Council will be entering into Executive Session for a discussion of matters related to an economic development project, to receive legal advice regarding a potential lawsuit, for a personnel matter, and action from Executive Session from the special called meeting held at 11:00am on August 12, 2024 to receive legal advice regarding the PFAS lawsuit.

Councilwoman NeSmith-Jackson made a motion to enter into Executive Session and Councilman Smith seconded the motion. Council voted unanimously (6-0) to enter into Executive Session at 2:58pm.

Council resumed open session at 3:22pm and took action on the following items:

Resolution No. 2024-35

A Resolution of City Council approving Downtown Redevelopment Grants for First Quarter, FY25.

Pro tem Jebaily made a motion to pass Resolution No. 2024-35 and Councilman McCall seconded the motion.

Council voted unanimously (6-0) in favor of the motion. Resolution No. 2024-35 was passed.

Action from Executive Session from the special called meeting held at 11:00am on August 12, 2024 to receive legal advice regarding the PFAS lawsuit.

Pro tem Jebaily made a motion to authorize the City Manager to work with city attorneys to opt out of additional PFAS/PFOA Class Action matters and to approve and authorize the filing of an action by the City relating to PFAS and PFOA damages to the City of Florence. Councilman McCall seconded the motion.

Council voted unanimously (6-0) in favor of the motion.

ADJOURN

Without objection, the August 12, 2024 Regular meeting of City Council was adjourned at 3:23pm.

Dated this 9th day of September 2024.

Casey C. Moore, Municipal Clerk

Teresa Myers Ervin, Mayor



**SPECIAL MEETING OF FLORENCE CITY COUNCIL
SATURDAY, AUGUST 17, 2024 – 8:00 A.M.
CITY COUNCIL CHAMBERS
324 WEST EVANS STREET
FLORENCE, SOUTH CAROLINA**

MEMBERS PRESENT

Mayor Pro Tempore George Jebaily, Councilwoman Lethonia Barnes, Councilman Chaquez T. McCall, Councilman Bryan A. Braddock, Councilman J. Lawrence Smith, II and Councilwoman LaShonda NeSmith-Jackson

MEMBERS ABSENT

Mayor Teresa Myers Ervin

ALSO PRESENT

Mr. Scotty Davis, City Manager; Mr. Clint Moore, Assistant City Manager of Development; Mrs. Amanda Pope, Director of Marketing, Communications and Municipal Services; Mr. Josh Whittington, Director of Utilities; Mr. Michael Hemingway, Director of Utility Planning and Economic Development; Mr. Jerry Dudley, Director of Planning; Mr. Robert Mott, Water Resources Manager; and Mr. Benjamin T. Zeigler, City Attorney

MEDIA PRESENT

Seth Taylor with the Post and Courier and a reporter with WPDE were present for the meeting.

Notices of this regular meeting of City Council were provided to the media and individuals requesting a copy of the agenda informing them of the date, location and time of the meeting.

CALL TO ORDER

Mayor Pro tem Jebaily called the August 17, 2024 special meeting of Florence City Council to order at 8:04 a.m.

INVOCATION

Councilwoman Barnes gave the invocation for the meeting. The pledge of allegiance to the American Flag followed the invocation.

EXECUTIVE SESSION

Pro tem Jebaily said Council will be entering into Executive Session to discuss information regarding a contractual matter.



**FLORENCE CITY COUNCIL
SPECIAL MEETING – AUGUST 17, 2024**

Councilwoman Barnes made a motion to enter into Executive Session and Councilman Smith seconded the motion. Council voted 6-0 to enter into Executive Session at 8:06 a.m.

Council resumed open session at 9:12 a.m.

Pro tem Jebaily asked Mr. Scotty Davis, City Manager, to provide an update of the situation that occurred that led to taking the surface water plant offline. He asked Mr. Davis to address the health of the system and what measures are being taken to address the critical failures that led to the plant's shutdown. Mr. Davis said the system is healthy and explained the city is a dual system, operating both ground water and surface water treatment facilities. The surface water treatment plant is currently back online and both systems are functioning adequately.

Mr. Davis explained the incident occurred due to sediment in the water entering the system but was also due to a failure on staff's part. In-house standard operating procedures were not followed, and executive level staff should have been notified earlier of the incident but were not. The city is engaging in a contract with engineering firm CDM Smith to ensure these issues do not occur in the system again.

Mr. Davis said the system-wide boil water advisory is still in effect and staff anticipates that it will be lifted on Sunday. Water samples will be collected throughout the system and be sent for testing. Internal testing has indicated no biological infiltration in the water.

Councilman Braddock thanked Mr. Davis for taking ownership of the situation and coming up with a plan.

ADJOURN

Without objection, the August 17, 2024 special meeting of City Council was adjourned at 9:17 a.m.

Dated this 9th day of September 2024.

Casey C. Moore, Municipal Clerk

Teresa Myers Ervin, Mayor

FLORENCE CITY COUNCIL MEETING

DATE: September 9, 2024

AGENDA ITEM: Ordinance

DEPARTMENT/DIVISION: Finance

I. SECOND READING OF AN ISSUE UNDER CONSIDERATION:

Series Ordinance making provision for the terms and conditions of an issue of combined waterworks and sewerage system capital improvement revenue bonds of the City of Florence, South Carolina, in the aggregate principal amount of not exceeding \$270,000,000 as authorized by a bond ordinance of the City of Florence, South Carolina, adopted October 24, 1989, as amended; and other matters relating thereto.

II. CURRENT STATUS/PREVIOUS ACTION TAKEN:

1. The City's Bond Ordinance, adopted on October 24, 1989, provides that upon adoption of a "Series Ordinance" there may be issued one or more series of Bonds for the purpose of providing funds for improvements and extensions to the Combine Waterworks and Sewerage System of the City.
2. At the July 31, 2024 regular meeting of the Finance Committee of Florence City Council, First Tryon Advisors presented to Council the financing and capital improvement plan to fund a number of major projects.
3. Council gave first reading to the Series Ordinance described under Section I above at its August 12, 2024 meeting.
4. Subsequent to the August 12 meeting, Administration consulted with the City's financial advisor and utility rate consultant and determined that potential water and sewer rate increases can be further mitigated by the issuance of bond anticipation notes ("BANS"). The BANS will be short term borrowings that will ultimately be paid by the bonds to be issued pursuant to the Series Ordinance. In addition, it may be advantageous to sell the BANS as a single instrument in a private sale to a bank or other lending institution rather than selling them in the Municipal Bond Market. Finally, several additional federal tax and securities disclosure provisions have been added to the Series Ordinance.
5. The Series Ordinance has been amended for second reading:
 - a. To provide for the sale and issuance of the BANS;
 - b. To allow for the sale of the BANS to a bank or other lending institution; and
 - c. To include additional federal tax and securities disclosure provisions listed in subsection 4 above.

III. POINTS TO CONSIDER:

1. This bond is the second of three separate bond issuances that will fund current and future major projects and will be paid off over a 30-year time span. Further bond issuance will follow a reevaluation of needs and costs.
2. The proposed ordinance will allow the City to secure the funding necessary to defray the costs of expanding the City's Surface Water Treatment Plant, upfitting the City's water system to address PFAS issues, and rehabilitating and upgrading the Jeffries Creek Sewer Interceptor.

IV. ATTACHMENTS:

1. Ordinance
2. Jeffries Creek Interceptor Improvement Study
3. Surface Water Treatment Plant Condition Assessment
4. Financing Plan Overview

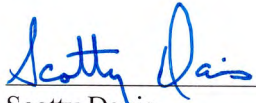

Scotty Davis
City Manager

A SERIES ORDINANCE

MAKING PROVISION FOR THE TERMS AND CONDITIONS OF AN ISSUE OF COMBINED WATERWORKS AND SEWERAGE SYSTEM CAPITAL IMPROVEMENT REVENUE BONDS OF THE CITY OF FLORENCE, SOUTH CAROLINA, IN ONE OR MORE SERIES, IN THE AGGREGATE PRINCIPAL AMOUNT OF NOT EXCEEDING \$270,000,000 AS AUTHORIZED BY A BOND ORDINANCE OF THE CITY OF FLORENCE, SOUTH CAROLINA, ADOPTED OCTOBER 24, 1989, AS AMENDED; AUTHORIZING THE ISSUANCE OF BOND ANTICIPATION NOTES; AND OTHER MATTERS RELATING THERETO.

SERIES ORDINANCE

STATE OF SOUTH CAROLINA

WHEREAS, the City Council (“**City Council**”) of the City of Florence (the “**City**”) has made general provision for the issuance of Combined Waterworks and Sewerage System Revenue Bonds through the means of an ordinance entitled “AN ORDINANCE PROVIDING FOR THE ISSUANCE AND SALE OF COMBINED WATERWORKS AND SEWERAGE SYSTEM REVENUE BONDS OF THE CITY OF FLORENCE, SOUTH CAROLINA, AND OTHER MATTERS RELATING THERETO,” adopted on October 24, 1989, as amended (the “**Bond Ordinance**”); and

WHEREAS, it is provided in and by the Bond Ordinance that, upon adoption of a “Series Ordinance” there may be issued one or more series of Bonds for the purpose of providing funds for improvements and extensions to the Combined Waterworks and Sewerage System of the City (the “**System**”); and

WHEREAS, the revenues derived from the System are now hypothecated and pledged to the payment of the following:

- a) the outstanding installments of an original issue of \$10,428,518 South Carolina Water Quality Revolving Fund Loan dated April 18, 2013;
- b) the outstanding installments of an original issue of \$3,817,741 South Carolina Water Quality Revolving Fund Loan dated September 23, 2013;
- c) the outstanding installments of an original issue of \$6,111,310.18 Waterworks and Sewerage System Junior Lien Revenue Bond dated March 10, 2014;
- d) the outstanding installments of an original issue of not exceeding \$1,750,566 plus capitalized interest, if any, South Carolina Water Quality Revolving Fund Loan dated September 11, 2014;
- e) the outstanding installments of an original issue of \$2,702,347.56 Combined Waterworks and Sewerage System Refunding Revenue Bond, Series 2015, dated July 15, 2015;
- f) the outstanding installments of an original issue of \$14,405,000 Combined Waterworks and Sewerage System Refunding Revenue Bonds, Series 2016, dated November 9, 2016;
- g) the outstanding installments of an original issue of \$9,055,000 Special Obligation Bonds (Florence Downtown Redevelopment Project Area), Taxable Series 2016A, dated November 9, 2016, additionally secured by a junior lien pledge of System revenues;
- h) the outstanding installments of an original issue of \$26,515,000 Special Obligation Bonds (Florence Downtown Redevelopment Project Area), Series 2016B, dated November 9, 2016, additionally secured by a junior lien pledge of System revenues;
- i) the outstanding installments of an original issue of not exceeding \$2,260,938 plus capitalized interest, if any, South Carolina Drinking Water Revolving Fund Loan dated June 14, 2018;

j) the outstanding installments of an original issue of not exceeding \$5,730,149 plus capitalized interest, if any, South Carolina Water Pollution Control Revolving Fund Loan dated June 14, 2018;

k) the outstanding installments of an original issue of \$68,590,000 Combined Waterworks and Sewerage System Refunding and Capital Improvement Revenue Bonds, Series 2019, dated October 3, 2019;

l) the outstanding installments of an original issue of \$15,252,000 Combined Waterworks and Sewerage System Refunding Improvement Revenue Bond, Series 2020, dated May 15, 2020; and

m) the outstanding installments of an original issue of \$32,100,000 Combined Waterworks and Sewerage System Refunding Improvement Revenue Bonds, Series 2023, dated September 27, 2023.

WHEREAS, the obligations described at (a), (b), (d) through (f), and (i) through (m) are hereinafter referred to as the **“Parity Bonds;”** and

WHEREAS, the City has further determined that it is necessary to construct certain capital improvements to the System, specifically, expanding the City’s Surface Water Treatment Plant and upfitting the City’s water system to address PFAS issues, and rehabilitating and upgrading the Jeffries Creek Sewer Interceptor (the **“Projects”**); and

WHEREAS, the City finds that the Series 2024 Bonds (as defined below) may be issued on a parity with the Parity Bonds pursuant to Section 4.02(A)(6) of the Master Ordinance; and

WHEREAS, it has been determined that not exceeding \$270,000,000 may be required in order to provide funds for (i) defraying a portion of the cost of the Projects; (ii) capitalized interest on the Series 2024 Bonds (defined below) if required to make payments on the Series 2024 Bonds prior to the Projects being fully completed, placed into service, and fully operational; and (iii) costs related to the financing and providing necessary reserves, if any; and

WHEREAS, by reason of the foregoing, it has been determined to adopt this ordinance as a “Series Ordinance” in accordance with the terms and provisions of the Bond Ordinance.

NOW, THEREFORE, BE IT ORDAINED BY THE CITY COUNCIL OF THE CITY OF FLORENCE, IN MEETING DULY ASSEMBLED:

ARTICLE I

DEFINITIONS AND AUTHORITY

Section 1.01. Definitions.

All terms which are defined in Section 2.02 of the Bond Ordinance shall have the same meanings in this Series Ordinance as such terms are prescribed to have in the Bond Ordinance.

“Continuing Disclosure Certificate” means that certificate which is to be executed by an

Authorized Official and delivered at or prior to the closing of the Bonds as required by Securities and Exchange Commission Rule 15c2-12, as amended.

Section 1.02. Authority for Series Ordinance.

This Series Ordinance is adopted pursuant to the provisions of the Bond Ordinance.

ARTICLE II

AUTHORIZATION AND TERMS OF THE SERIES OF BONDS

Section 2.01. Conditions Precedent to Issuance of Series of Bonds.

The Bond Ordinance provides that a Series Ordinance shall be adopted with respect to each Series of Bonds which Series Ordinance shall express the approval of City Council to the issuance of a Series of Bonds and City Council's agreement to abide by the terms, provisions and agreements set forth in the Bond Ordinance and shall specify and determine:

- 1) As prescribed by Section 6-17-60 of the Enabling Act, the then period of usefulness of the System;
- 2) The Date or Dates of Issue of such Series of Bonds;
- 3) The precise principal amount of the Series of Bonds;
- 4) The specific purposes for which the proceeds of such Series will be used;
- 5) The title and designation of the Bonds of such Series and manner of numbering and lettering, and the denomination or denominations of the Bonds of such Series;
- 6) The date or dates of maturity and the amounts thereof;
- 7) The interest rate or rates, or the manner of determining such rate or rates, of the Bonds of such Series;
- 8) The time for the payment of interest on the Bonds in such Series and the Record Date;
- 9) The redemption price or redemption prices and the redemption date or redemption dates and other terms of redemption (if any) applicable to any of the Bonds of such Series for such payments;
- 10) The Registrar for such Bonds if other than the Trustee;
- 11) The portion of such Series that are serial Bonds and that are term Bonds, if any, including the amount and date of each mandatory redemption or sinking fund installment, if any, required by such Series Ordinance to be paid for the retirement of any such Bonds;
- 12) The portion of such Series that are Capital Appreciation Bonds, if any, including the time for payment of such Capital Appreciation Bonds in order to address the information requested in paragraphs (7) and (8) above.

13) Any other applicable redemption requirement for the Bonds of such Series and the method of satisfying the same;

14) The manner in which Bonds of such Series are to be sold and provisions for the sale thereof;

15) The form or forms for the Bonds of each Series;

16) That the then applicable Reserve Requirement has been or will be met;

17) The disposition of the proceeds of the sale of the Bonds of such Series and the manner of their application; and

18) Any other provisions deemed advisable by the City not in conflict with or in substitution for the provisions of the Bond Ordinance and the Series Ordinance relating to the Bonds of such Series.

Section 2.02. Findings, Determinations, Agreements and Covenants.

Pursuant to the provisions of the Bond Ordinance described in Section 2.01 above, it is hereby found and determined that, and the City hereby covenants and agrees, as applicable:

1) The useful life of the System is found to be 40 years.

2) The Date of Issue of the Bonds whose issuance is provided for herein (the “**Series 2024 Bonds**”) is to be the date of delivery of the Series 2024 Bonds.

3) The Series 2024 Bonds shall be in one or more series in the original principal amount of not exceeding \$270,000,000. The final principal amount and maturity schedule shall be set forth in a certificate to be signed by the Mayor and included with this Ordinance in the records of City Council.

4) The proceeds of the Series 2024 Bonds shall be used, subject to the provisions of paragraphs 6 and 12 below, to provide moneys which will be sufficient to pay (i) a portion of the cost of the Projects; (ii) capitalized interest on the Series 2024 Bonds (defined below) if required to make payments on the Series 2024 Bonds prior to the Projects being fully completed, placed into service, and fully operational; and (iii) costs related to the financing and providing necessary reserves, if any.

5) The Series 2024 Bonds shall be designated City of Florence, South Carolina, Combined Waterworks and Sewerage System Capital Improvement Revenue Bonds, Series 2024 (or such other designation as shall be set forth in a certificate to be signed by the Mayor and with such further designation to indicate more than one series) and shall be issued in registered form. The Series 2024 Bonds shall be numbered and lettered in such way as to maintain a proper record thereof and will be issued in the form of a single bond per each maturity.

6) The Mayor of the City is hereby authorized and empowered to determine the aggregate principal amount of the Series 2024 Bonds, the principal amount of each maturity of the Series 2024 Bonds, the interest rates for the Series 2024 Bonds, the Series 2024 Bonds to be subject to mandatory and optional redemption and the redemption prices of the Series 2024 Bonds subject to optional redemption, any such other information as may be necessary to effect the issuance of the Series 2024 Bonds and shall

be set forth in a certificate to be signed by the Mayor and included with this Ordinance in the records of City Council.

7) Interest on the Series 2024 Bonds shall be payable as set forth in a certificate to be signed by the Mayor and included with this Ordinance in the records of City Council.

8) Such of the Series 2024 Bonds as the Mayor shall determine pursuant to paragraph (6) above shall be subject to mandatory redemption at the redemption price equal to the principal amount of the Series 2024 Bonds to be redeemed, together with interest accrued from the date of redemption, in the years and in the amounts determined by the Mayor and shall be set forth in a certificate to be signed by the Mayor and included with this Ordinance in the records of City Council.

9) The Registrar for the Series 2024 Bonds shall be the Trustee under the Bond Ordinance.

10) The Series 2024 Bonds shall be sold, upon consultation with First Tryon Advisors as Financial Advisor, at competitive sale; provided, however, that the Series 2024 Bonds may be sold by negotiated sale if the Mayor, in consultation with First Tryon Advisors, determines that market conditions are such that a negotiated sale will be more in the City's best interests than a competitive sale. City Council hereby authorizes the Mayor to approve the Preliminary Official Statement and to ratify the use of such Preliminary Official Statement by the successful purchaser of the Series 2024 Bonds in connection with the offering of any Series of Bonds by the successful purchaser. City Council hereby authorizes the preparation and distribution of the Official Statement with respect to such Series of Bonds. The Final Official Statement shall be approved on behalf of the City by the Mayor.

11) The Series 2024 Bonds shall be substantially in the form attached hereto as Exhibit A.

12) The proceeds of the Series 2024 Bonds shall be applied as set forth in a certificate to be signed by the Mayor and included with this Ordinance in the records of City Council.

13) City Council hereby authorizes the issuance of the Series 2024 Bonds and agrees to abide by all of the terms, provisions and agreements set forth in the Bond Ordinance.

14) City Council hereby approves the issuance of the Series 2024 Bonds in substantially the form attached hereto as Exhibit A, with such changes as shall be appropriate following the sale of the Series 2024 Bonds.

15) The City finds that the provisions of Section 4.02(A) and (B) of the Bond Ordinance may be satisfied permitting the Series 2024 Bonds to be issued on a parity with the outstanding Parity Bonds.

16) City Council hereby authorizes the issuance of one or more series of notes in anticipation of the receipt of proceeds of any of the Series 2024 Bonds authorized hereunder (the "BANS"); provided that no such BANS shall be issued unless all conditions for issuance of the Series 2024 Bonds in an amount not less than the principal amount of the BANS provided for in the Bond Ordinance and this Series Ordinance shall have been satisfied, except for the requirements of Section 4.02(3) of the Bond Ordinance, which may be satisfied by the delivery to the Trustee of a certificate of a Financial Consultant or Consulting Engineer demonstrating that, at the time of the anticipated issuance of the Bonds to pay such BANS, all such conditions are reasonably projected to have been satisfied, and the Mayor of the City shall have delivered to the Trustee a certificate stating that, pursuant to this Series Ordinance, the City irrevocably commits to issue, in the manner prescribed by law, the Bonds or refunding BANS in an

amount, not less than the principal amount of any BANS issued hereunder, not to exceed \$270,000,000. Any BANS shall be stated to mature not more than one year following the date of delivery thereof and the City Manager of the City is authorized to negotiate for the sale of such BANS at either public or private sale on terms he deems to be in the best interests of the City. All terms contained in this Section 2.02 relating to the sale of the Series 2024 Bonds as may be applicable to any BANS shall be applied to the BANS. Any of the BANS may be sold as a single instrument to a bank or other lending institution, and if so sold, may be structured to provide for the delivery of the entire par amount thereof and premium, if any, to the City at closing, or may provide for the periodic disbursement of portions of the par amount thereof to and as required by the City during the term of such BAN. Interest shall accrue on each amount so disbursed from the date of its disbursement to the City.

17) In accordance with Act No. 442 of the Acts and Joint Resolutions of the General Assembly of the State of South Carolina for the year 1994, the City hereby covenants to file with a central repository for availability in the secondary bond market when requested (1) an annual independent audit, within thirty days of the City's receipt of the audit; and (2) event specific information, within thirty days of an event adversely affecting more than five percent of the City's revenue or tax base. The only remedy for failure by the City to comply with the covenant in this Section 17 shall be an action for specific performance of this covenant.

18) The City hereby covenants and agrees that it will comply with and carry out all of the provisions of the Continuing Disclosure Certificate. Notwithstanding any other provision of this Ordinance, failure of the City to comply with the Continuing Disclosure Certificate shall not be considered an event of default hereunder; however, any Bondholder may take such actions as may be necessary and appropriate, including seeking mandamus or specific performance by court order, to cause the City to comply with its obligations under this Section 18. The Continuing Disclosure Certificate shall be executed by an Authorized Officer prior to the delivery of the Bonds and shall be in such form as shall be determined by the City Manager of the City, upon advice of counsel, do be compliant with applicable law. However, in the event the City determines to engage the services of a disclosure dissemination agent for the purpose of disseminating information to meet the requirements of the Securities and Exchange Commission Rule 15c2-12(b)(5), the City may enter into a disclosure dissemination agent agreement in a form acceptable to the City in lieu of executing said Continuing Disclosure Certificate. The execution of either the Continuing Disclosure Certificate or the disclosure dissemination agent agreement shall constitute conclusive evidence of the approval by the person executing the same of any and all modifications and amendments thereto.

19) The City will comply with all requirements of the Code in order to preserve the tax-exempt status of the Bonds or BANS, including without limitation, the requirement to file the information report 8038-G with the Internal Revenue Service. In this connection, the City covenants to execute any and all agreements, certificates and other documentation as it may be advised by bond counsel will enable it to comply with this Section, and such agreements, certificates and other documentation may be executed by an Authorized Officer and by the City Manager of the City or either of them.

The City hereby represents and covenants that it will not take any action which will, or fail to take any action which failure will, cause interest on the Bonds or BANS to become includable in the gross income of the Holder thereof for federal income tax purposes pursuant to the provisions of the Code and regulations promulgated thereunder in effect on the date of original issuance of Bonds or BANS. Without limiting the generality of the foregoing, the City represents and covenants that:

- a) All property provided by the net proceeds of the Bonds or BANS will be owned by the

City in accordance with the rules governing the ownership of property for federal income tax purposes.

b) The City shall not permit the proceeds of the Bonds or BANS or any facility financed with the proceeds of the Bonds or BANS to be used in any manner that would result in (a) ten percent (10%) or more of such proceeds being considered as having been used directly or indirectly in any trade or business as provided in Section 141(b) of the Code, or (b) five percent (5%) or more of such proceeds being considered as having been used directly or indirectly to make or finance loans to any person other than a governmental unit as provided in Section 141(c) of the Code.

c) The City is not a party to nor will it enter into any contracts with any person for the use or management of any facility provided with the proceeds of the Bonds or BANS that do not conform to the guidelines set forth in Revenue Procedure 2017-13, as may be subsequently modified by applicable pronouncements of the United States Treasury Department.

20) Careful consideration has been given to the time in which the expenditures of the proceeds of the Bonds or BANS will be made. It has been ascertained that all of the money received from the proceeds of the Bonds or BANS will be expended within the limitations imposed by Section 148 of the Code and the Treasury regulations promulgated pursuant thereto. Accordingly, the City will be able to certify upon reasonable grounds that the Bonds and BANS herein provided for are not “arbitrage bonds” within the meaning of Section 148 of the Code.

21) City Council hereby authorizes the Mayor or the City Manager to take such further action, including but not limited to the execution of any document or certificate, as may be necessary to effect the issuance of the Series 2024 Bonds and any BANS.

DONE, RATIFIED AND ADOPTED THIS 9th day of September, 2024.

Mayor, City of Florence, South Carolina

Attest:

Municipal Clerk, City of Florence,
South Carolina

First Reading: August 12, 2024
Second Reading: September 9, 2024

(FORM OF BOND)

CITY OF FLORENCE, SOUTH CAROLINA
COMBINED WATERWORKS AND SEWERAGE SYSTEM
CAPITAL IMPROVEMENT REVENUE
BONDS, SERIES 2024

No. R-__

<u>Interest Rate</u>	<u>Maturity Date</u>	<u>Date of Issue</u>	<u>CUSIP</u>
_____%	September 1, 20__	_____, 2024	

Registered Owner: CEDE & CO.

Principal Amount:

THE CITY OF FLORENCE, SOUTH CAROLINA (the “City”) acknowledges itself indebted and for value received hereby promises to pay, solely from the sources and as hereinafter provided, to the Registered Holder named above or registered assigns, the Principal Amount set forth above on the Maturity Date stated above, unless this Bond be subject to redemption and shall have been redeemed prior thereto as hereinafter provided, upon presentation and surrender of this Bond at the corporate trust office of The Bank of New York Mellon Trust Company, N.A. (the “Trustee”) in the City of Pittsburgh, State of Pennsylvania, and to pay interest on such principal amount at the annual Interest Rate stated above (calculated on the basis of a 360-day year of twelve 30-day months) from the later of _____ 1, 20__, or the date to which interest has been paid immediately preceding the authentication date hereof, unless the authentication date hereof is a March 1 or a September 1, in which event this Bond will bear interest from the earlier of such authentication date or the date to which interest has last been paid; provided that if the City shall fail to pay interest on ____ 1, 20__, then this Bond will bear interest from _____ 1, 20__. Interest on this Bond is payable on March 1 and September 1 of each year beginning ____ 1, 20__. The interest so payable on any March 1 or September 1 will be paid to the person in whose name this Bond is registered at the close of business on the February 15 or August 15 immediately preceding such March 1 or September 1 (the “Record Date”) by check or draft mailed at the times provided herein from the office of the Trustee to the person in whose name this Bond is registered on the Record Date at the address shown on the registration books, provided that, at the request of the Registered Holder of \$1,000,000 or more in aggregate principal amount of Bonds, such payments shall be made by wire transfer to an account within the continental United States as such Registered Holder shall designate in writing to the Trustee on or before the Record Date. The principal of, redemption premium, if any, and interest on this Bond are payable in any coin or currency of the United States of America which at the time of payment is legal tender for the payment of public and private debts.

Both the principal of and interest on this Bond, as the same shall become due, are payable solely from the Net Earnings (as defined in the Ordinances described herein) derived from the operation of the Combined Waterworks and Sewerage System of the City (the “System”) as described herein. This Bond shall not in any event constitute an indebtedness of the City within the meaning of any provision, limitation or restriction of the Constitution or statutes of the State of South Carolina (the “State”). The

City is not obligated to pay this Bond, or the interest hereon, save and except from Net Earnings derived from the operation of the System.

THIS BOND HAS BEEN ISSUED UNDER THE PROVISIONS OF TITLE 6, CHAPTER 17, CODE OF LAWS OF SOUTH CAROLINA, 1976, AS AMENDED, AND DOES NOT CONSTITUTE AN INDEBTEDNESS OF THE CITY WITHIN STATE CONSTITUTIONAL PROVISIONS (OTHER THAN ARTICLE X, SECTION 14, PARAGRAPH 10 OF THE SOUTH CAROLINA CONSTITUTION AUTHORIZING OBLIGATIONS PAYABLE SOLELY FROM SPECIAL SOURCES NOT INVOLVING REVENUES FROM ANY TAX OR LICENSE). THIS BOND AND THE BONDS OF THE SERIES OF WHICH IT IS ONE SHALL NOT CONSTITUTE A DEBT OF THE CITY, NOR A CHARGE, LIEN OR ENCUMBRANCE, LEGAL OR EQUITABLE, UPON ANY PROPERTY OF THE CITY OR ON ANY INCOME, RECEIPTS OR REVENUES THEREOF, OTHER THAN THE AFORESAID NET EARNINGS OF THE SYSTEM PLEDGED THERETO. NO RECOURSE SHALL BE HAD FOR THE PAYMENT OF THIS BOND OR THE INTEREST THEREON AGAINST THE GENERAL FUND OF THE CITY AND NEITHER THE CREDIT NOR THE TAXING POWER OF THE CITY SHALL BE DEEMED TO BE PLEDGED THERETO. THE FULL FAITH, CREDIT AND TAXING POWERS OF THE CITY ARE NOT PLEDGED TO THE PAYMENT OF THE PRINCIPAL OF OR INTEREST ON THIS BOND.

This Bond shall not be valid or obligatory for any purpose until the Certificate of Authentication hereon shall have been duly executed by the Registrar, initially the Trustee.

[The Bonds maturing September 1, 20__, and thereafter, are subject to redemption prior to maturity, at the option of the City, on and after September 1, ____, in whole or in part at any time (but if in part, in such order of maturities as shall be determined by the City) at par plus interest accrued to the redemption date.]

[The Bonds maturing on September 1, 20__, are subject to mandatory sinking fund redemption commencing September 1, ____, and will be redeemed (to the extent not previously redeemed), at one hundred percent (100%) of the principal amount, plus interest accrued to the redemption date, on September 1 of each of the following years in the respective principal amounts for each year specified below:

<u>Year</u>	<u>Amount</u>
-------------	---------------

The amount of the mandatory sinking fund redemption prescribed above for the Bonds of any maturity shall be reduced to the extent Bonds of such maturity have been purchased by the City or redeemed by the City pursuant to the optional redemption provisions set forth above, in such manner as the City shall direct, or, absent such direction, on a *pro rata* basis.]

If less than all of any maturity of the Bonds are to be redeemed, the particular Bonds or portions of Bonds to be redeemed shall be selected by the Trustee by lot. Bonds in a denomination of more than \$5,000 may be redeemed in part from time to time in one or more units of \$5,000 in the manner provided in the Bond Ordinance.

If any of the Bonds, or portions thereof, are called for redemption, the Trustee will give notice to the Holders of any such Bonds to be redeemed, in the name of the City, of the redemption of such Bonds,

or portions thereof, which notice will specify the Bonds to be redeemed, the redemption date and the place or places where amounts due upon such redemption will be payable and, if less than all of the Bonds are to be redeemed, the numbers of such Bonds so to be redeemed, and, in the case of Bonds to be redeemed in part only, such notice will also specify the respective portions of the principal amount thereof to be redeemed. Such notice will be given by mailing a copy of the redemption notice by first class mail at least 30 days prior to the date fixed for redemption to the Holder of each Bond to be redeemed, at the address shown on the registration books; provided, however, that the failure to give such notice by mail, or any defect in the notice mailed to the Holder of any Bond, shall not affect the validity of the proceedings for the redemption of any other Bond. Provided funds for their redemption are on deposit with the Trustee, all Bonds so called for redemption will cease to bear interest on the specified redemption date.

This Bond is one of a Series of Bonds in the aggregate principal amount of \$ _____ of like tenor, except as to number, rate of interest, date of maturity and redemption provisions, issued pursuant to and in accordance with the Constitution and statutes of the State of South Carolina (the “**State**”), including particularly Chapter 17, Title 6, Code of Laws of South Carolina 1976, as amended (the “**Enabling Act**”), an ordinance duly adopted by the City Council of the City of Florence (“**Council**”) on October 24, 1989, as amended by series ordinances duly adopted by Council on April 12, 2010 and December 12, 2011 (collectively, the “**Bond Ordinance**”), as supplemented by an ordinance (the “**Series Ordinance**”) duly adopted by Council on _____, 2024 (the Bond Ordinance and the Series Ordinance are hereinafter collectively referred to as the “**Ordinances**”) for the purpose of providing funds for certain capital improvements to the System secured by a pledge of System revenues.

Certain capitalized terms used herein and not otherwise defined shall have the meanings ascribed thereto in the Ordinances. Certified copies of the Ordinances are on file in the office of the Trustee and in the office of the Clerk of Court for Florence County, South Carolina.

The Bond will be issued on a parity with the City’s outstanding Parity Bonds (as defined in the Series Ordinance) and any Additional Bonds hereafter issued.

The City has covenanted to continuously operate and maintain the System and fix and maintain such rates for the services and facilities furnished by the System as shall at all times be sufficient (a) to provide for the payment of the expenses of the administration and operation and such expenses for maintenance of the System as may be necessary to preserve the same in good repair and working order, (b) to provide for the punctual payment of the principal of and interest on the Bonds and all Junior Lien Bonds, (c) to maintain the Debt Service Fund and thus provide for the punctual payment of the principal of and interest on the Bonds, (d) to maintain each Debt Service Reserve Fund in the manner prescribed in the Ordinances, (e) to build and maintain a reserve for depreciation of the System, for contingencies and for improvements, betterments and extensions to the System other than those necessary to maintain the same in good repair and working order, and (f) to discharge all obligations imposed by the Enabling Act and the Ordinances.

For the payment of the principal of and interest on the Bonds, there are hereby irrevocably pledged the Net Earnings of the System; and a lien upon such Net Earnings has been granted to the Holders of the Bonds.

This Bond and the interest hereon are exempt from all State, county, municipal, school district, and all other taxes or assessments imposed within the State, direct or indirect, general or special, whether

imposed for the purpose of general revenue or otherwise, except inheritance, estate, transfer or certain franchise taxes.

This Bond is transferable, as provided in the Bond Ordinance, only upon the registration books of the City kept for that purpose by the Trustee or other registrar, by the Holder hereof in person or by his duly authorized attorney, upon (a) surrender of this Bond and an assignment with a written instrument of transfer satisfactory to the Trustee duly executed by the Holder hereof or his duly authorized attorney and (b) payment of the charges, if any, prescribed in the Bond Ordinance. Thereupon a new Bond or Bonds of the same aggregate principal amount, maturity and interest rate shall be issued to the transferee in exchange therefor as provided in the Bond Ordinance. The City, the Trustee and any Registrar may deem and treat the person in whose name this Bond is registered as the absolute owner hereof for the purpose of receiving payment of or on account of the principal or redemption price hereof and interest due hereon and for all other purposes.

For every exchange or transfer of the Bonds, the City or the Trustee or Registrar, as the case may be, may make a charge sufficient to reimburse it for any tax, fee or other governmental charge required to be paid with respect to such exchange or transfer.

It is hereby certified and recited that all conditions, acts and things required by the Constitution and statutes of the State to exist, be performed or happen precedent to or in the issuance of this Bond, exist, have been performed and have happened, and that the amount of this Bond, together with all other indebtedness of the City, does not exceed any limit prescribed by such Constitution or statutes.

IN WITNESS WHEREOF, CITY OF FLORENCE, SOUTH CAROLINA, has caused this Bond to be signed by the manual signature of the Mayor of the City, its seal to be reproduced hereon and the same to be attested by the manual signature of the Municipal Clerk of the City.

CITY OF FLORENCE, SOUTH CAROLINA

(SEAL)

By _____
Mayor, City of Florence, South Carolina

Attest:

By _____
Municipal Clerk of the City of Florence,
South Carolina

CERTIFICATE OF AUTHENTICATION

This Bond is the Bond of the Series described in the within mentioned Bond Ordinance.

THE BANK OF NEW YORK MELLON TRUST
COMPANY, N.A., as Trustee

Authorized Signatory

Date: _____, 2024

ASSIGNMENT

FOR VALUE RECEIVED the undersigned hereby sells, assigns and transfers unto

(please print or type name and address of Transferee and Social Security or other identifying number of Transferee)

the within Bond and all rights and title thereunder, and hereby irrevocably constitutes and appoints attorney to transfer the within Bond on the books kept for registration thereof, with full power of substitution in the premises.

Date: _____

Signature Guaranteed:

STATE OF SOUTH CAROLINA

COUNTY OF FLORENCE

I, the undersigned, Municipal Clerk of the City of Florence, South Carolina (“**City Council**”), DO HEREBY CERTIFY:

That the foregoing constitutes a true, correct and verbatim copy of an Ordinance adopted by City Council. The Ordinance was read at two public meetings of City Council held on August 12 and September 9, 2024. An interval of at least six days occurred between each reading. At each meeting, a quorum of City Council was present and remaining present throughout the meeting.

The Ordinance is now in full force and effect.

IN WITNESS WHEREOF, I have hereunto set my Hand this ____ day of September, 2024.

Casey Moore
Municipal Clerk, City of Florence, South Carolina



Jeffries Creek Interceptor Improvement Study Report

SUBMITTED TO: **CITY OF FLORENCE, SC**

MARCH 2017

**CDM
Smith**



5400 Glenwood Avenue, Suite 400
Raleigh, North Carolina 27612
tel: 919 325-3500

March 21, 2017

Mr. Michael Hemingway
City of Florence Utilities
324 West Evans Street
Florence, SC 29501

Subject: Reclaimed Water Master Plan
Draft Report

Dear Mr. Hemingway:

Enclosed please find four copies of the Jeffries Creek Interceptor Improvement Study draft report. This report briefly summarizes the process of developing conceptual improvement alternatives and selecting a recommended improvement plan to increase the hydraulic capacity of the Jeffries Creek interceptors.

We look forward to discussing the report with you at your convenience. If you have any questions, please feel free to contact me. Thank you for the opportunity to work with you on this project.

Sincerely,

A handwritten signature in blue ink, appearing to read "Sheryl D. Smith".

Sheryl D. Smith, P.E.
CDM Smith Inc.

Enclosures: 4 copies of draft report



Table of Contents

Section 1.0 Project Goals and Objectives

Section 2.0 Project Area Description

2.1 Northern Interceptor	1
2.2 Southern Interceptor	3
2.3 Interconnections.....	3
2.4 FRWWMF Influent Pump Station	3

Section 3.0 Evaluation of Wastewater Flows

3.1 Flow Monitoring	4
3.2 Antecedent Conditions and Flow Adjustments	4
3.3 Future Wastewater Flows	6

Section 4.0 Hydraulic Modeling and Capacity Analysis

4.1 Model Development and Calibration	6
4.2 Capacity Analysis.....	7

Section 5.0 Alternative 1 – Gravity Pipe Upsizing

5.1 Alternative 1 – Gravity Pipe Upsizing.....	10
5.2 Alternative 2 – Pump to Northern Interceptor.....	13
5.3 Alternative 3 – Pump to FRWWMF.....	18

Section 6.0 Phasing and Evaluation of Preferred Alternatives

6.1 Preliminary Phasing.....	21
6.2 Alternatives Evaluation	21

Section 7.0 Recommendations and Additional Considerations

7.1 Recommended Phase 1 Projects.....	24
7.2 Additional Considerations.....	25

List of Figures

Figure 1	City of Florence Wastewater Collection System	2
Figure 2	Flow Monitored Areas with Higher RDI/I	5
Figure 3	Peak Dry Weather Flow Capacity	8
Figure 4	Hydraulic Profile of Northern Interceptor During Peak Wet-Weather Design Flow	9
Figure 5	Hydraulic Profile of Southern Interceptor During Peak Wet-Weather Design Flow	9
Figure 6	Alternative 1 – Gravity Pipe Upsizing.....	11
Figure 7	Alternative 2 – Pump to Northern Interceptor.....	14
Figure 8	Hydraulic Profile of Southern Interceptor Downstream of New Pump Station During Peak Wet-Weather Design Flow (Alternatives 2A, 2B, and 2C)	16
Figure 9	Alternative 2E – Preferred Option for Pumping to Northern Interceptor.....	19
Figure 10	Alternative 3 – Pump to Florence Regional WWMF	20
Figure 11	Alternative 1B Phasing	22
Figure 12	Alternative 2E Phasing.....	22
Figure 13	Alternative 3 Phasing	23

List of Tables

Table 1	Alternative 2 Variations on Pump Station Location, Force Main Routing, and Length of Gravity Sewer Replacement.....	15
Table 2	Alternative 2 Capital Costs.....	17
Table 3	Alternatives Evaluation Matrix	24

Jeffries Creek Interceptor Improvement Study

City of Florence, South Carolina

1.0 Project Goals and Objectives

The City of Florence (City) initiated a sanitary sewer collection system study focusing on Jeffries Creek interceptors with the goal of developing conceptual improvement alternatives and selecting a recommended improvement plan to increase the hydraulic capacity of the Jeffries Creek interceptors. This study includes a physical survey of all manholes on the Jeffries Creek interceptors, sanitary sewer system flow monitoring, a hydraulic analysis of the Jeffries Creek sanitary sewer interceptors, and a stormwater analysis using a watershed model of Jeffries Creek. The purpose of the watershed model is to determine the elevation of Jeffries Creek during various return-period storm events so that low lying manholes can be identified as potential sources of rainfall dependent infiltration/inflow (RDI/I). The results of the hydraulic analysis of the Jeffries Creek interceptors and the watershed model of Jeffries Creek were used to develop conceptual improvements for the Jeffries Creek interceptors.

2.0 Project Area Description

The Jeffries Creek basin is one of the five major sewer basins comprising the City's wastewater collection system. The Jeffries Creek basin has the oldest of the City's trunk sewer systems and serves downtown Florence and the residential and business communities in the city center. The system has two parallel trunk sewers on the northern and southern sides of Jeffries Creek, as shown in **Figure 1**.

2.1 Northern Interceptor

The northern Jeffries Creek interceptor is the oldest in the system and was constructed in 1951, along with the original components of the treatment plant. The northern interceptor starts as a 12-inch diameter vitrified clay (VC) sewer at Cashua Drive and ends as a 27-inch diameter VC sewer where it joins with the 24-inch Pye Branch trunk sewer. Wastewater flow from the combined 27-inch and 24-inch pipes continues to the Florence Regional Wastewater Management Facility (FRWWMF) through a 24-inch diameter pipe. For approximately 3,500 feet upstream of Pye Branch, the northern interceptor is paralleled by a 15-inch diameter trunk sewer that serves the downtown area.



Northern Interceptor Along Wisteria Dr.

There is reasonably good access to a majority of the northern interceptor, since it is routed along several roadways, runs through open fields, or is close to the Florence Country Club golf course. However, several shorter portions of the line are behind private homes, run between houses, or are routed through low swampy

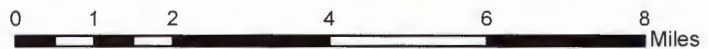
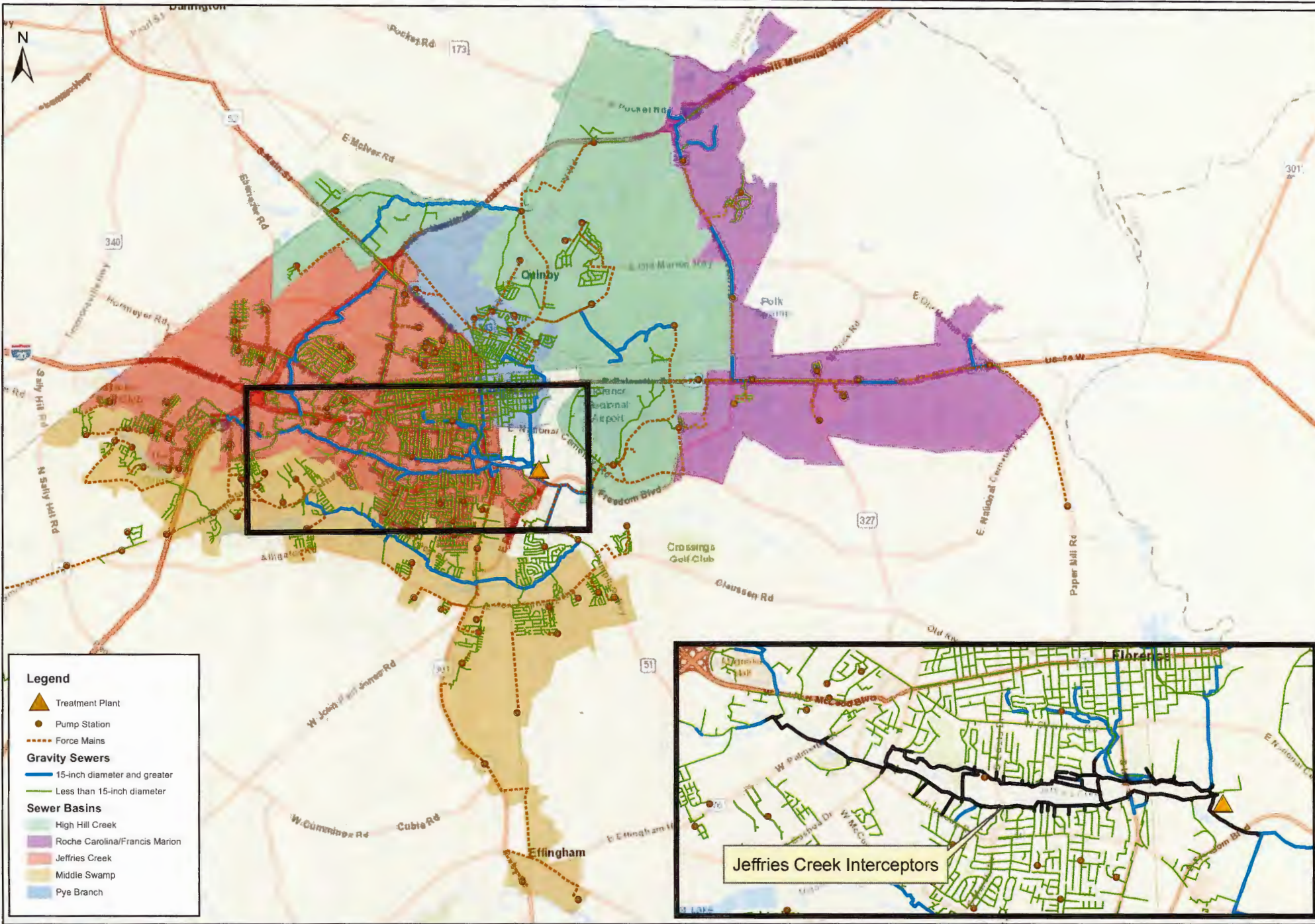

Figure 1
City of Florence Wastewater Collection System

areas. Generally, the ground elevations along this interceptor are higher than those along the southern interceptor and thus the manhole rims are predominantly at grade or less than a foot above ground level. The northern interceptor crosses four major highways, plus an elevated railroad line that parallels Church Street. There are several locations where the interceptor runs extremely close to or under structures.

2.2 Southern Interceptor

The southern Jeffries Creek interceptor was originally constructed in 1966 from Cashua Drive to the FRWWMF. In the 1970's, the southern interceptor was extended on the upstream end to serve new developments in the western portion of the collection system. Currently, the southern



Manholes Along Southern Interceptor

interceptor consists of 18-inch, 21-inch, and 24-inch diameter VC pipe starting at Woody Jones Boulevard and continuing to the junction with the High Hill Creek interceptor just upstream of the FRWWMF. Approximately 1.5 miles of an 18-inch diameter segment of the southern interceptor was paralleled with an 18-inch diameter relief sewer between Cashua Drive and Sylvan Drive in the 1990s.

Access to the majority of the southern interceptor is very limited due to the wetlands and heavily forested woodlands through which these sewers were installed, and also by the lack of proximity to secondary roads and cul-de-sacs on the south side of this interceptor. Almost the entire line is located within or very close to regulatory wetlands, without dedicated rights-of-way for maintenance access. Manholes in the lower wetland areas are mostly at grade, however, a few manhole rims have been raised in the recent past to an elevation about 5 feet above grade.

The southern interceptor crosses under six major highways, plus an elevated railroad line that parallels Church Street. There is also a section of the uppermost portion of this interceptor that crosses Jeffries Creek and was constructed on wooden piles and is exposed at an elevation half in and half out of the standing water.

2.3 Interconnections

There are interconnecting sewers between the northern interceptor (higher elevation) and southern interceptor (lower elevation) along Cashua Drive, Deberry Boulevard, and at Gully Branch.

2.4 FRWWMF Influent Pump Station

The northern and southern Jeffries Creek interceptors combine in a 42-inch pipe which leads into the bar screens upstream of the FRWWMF influent pump station. The Pye Branch basin trunk sewer joins with the northern interceptor and the High Hill Creek basin trunk sewer joins with the southern interceptor upstream of the pump station. The wastewater flow from the Roche Carolina/Francis Marion basin is pumped to the southern interceptor just upstream of the influent pump station.



Southern Interceptor Creek Crossing near Woody Jones Blvd

The wastewater flow from the Middle Swamp basin is pumped directly to the headworks, which is downstream of the influent pump station at the FRWWMF.

The firm capacity through the bar screens and influent pump station is 42 mgd. The headworks facility at the plant has a hydraulic capacity of 60 mgd.

3.0 Evaluation of Wastewater Flows

3.1 Flow Monitoring

Flow monitoring and rainfall data were collected at 19 locations throughout the wastewater collection system from January 4, 2012 through March 1, 2012 with the purpose of developing dry-weather and wet-weather flows for the calibration of the hydraulic model of the Jeffries Creek Interceptors and quantifying rainfall-dependent infiltration and inflow (RDI/I) to identify areas experiencing the highest RDI/I. Environmental Protection Agency (EPA) approved analysis software was used to assist in separating measured wastewater flows into base wastewater flow, groundwater infiltration, and RDI/I components.

Two factors were considered when identifying sewersheds with the highest relative levels of RDI/I. The first factor is the R value, which represents the amount of RDI/I entering the system in each sewershed. Typically, R values greater than two percent indicate a potential need for I/I reduction. The monitors representing Pye Branch sewershed (PYE1 and PYE2), and sewersheds in the downtown portion of Florence generally bounded by Lucas Street, Irby Street, Cherokee Road, and Cashua Drive (JN3 and JN4) recorded R-values greater than 2 percent. The second factor is the peak wet-weather flow to average dry-weather flow ratio. Even if the volume of infiltration is low, inflow could be producing high peaks that lead to overflows and surcharging. The maximum wet-weather peaking factor recorded by the flow monitors was compared to the peaking factor calculated from the Ten State Standards. Flow monitors representing the High Hill Creek sewershed upstream of the Police Cabin pump station (HH1 and HH2), the Pye Branch sewershed (PYE1 and PYE2), and downtown Florence sewersheds (JN2, JN3, and JN4), had higher peaking factors than as calculated using the Ten State Standards and therefore have higher than typical RDI/I. Areas with R value greater than 2 percent or peaking factor greater than the Ten State Standards are shown in **Figure 2**.

3.2 Antecedent Conditions and Flow Adjustments

The Florence area experienced drier than average conditions prior to and during the 2012 flow monitoring period. The total precipitation over the year preceding flow monitoring was 16 inches below average. Since stream flow/groundwater and rainfall conditions both influence wastewater flow and the flow monitoring took place during unusually dry conditions with low stream flow/groundwater conditions, the monitored flows are lower than what would typically be expected during average antecedent conditions. For the interceptor capacity analysis, it is desirable to use wastewater flows that reflect a more typical antecedent moisture condition and represent average-to-high groundwater infiltration and RDI/I that would be expected to enter the City's wastewater collection system. To account for this, the wastewater flows used for hydraulic modeling capacity analysis were adjusted as follows.

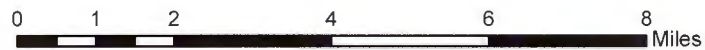
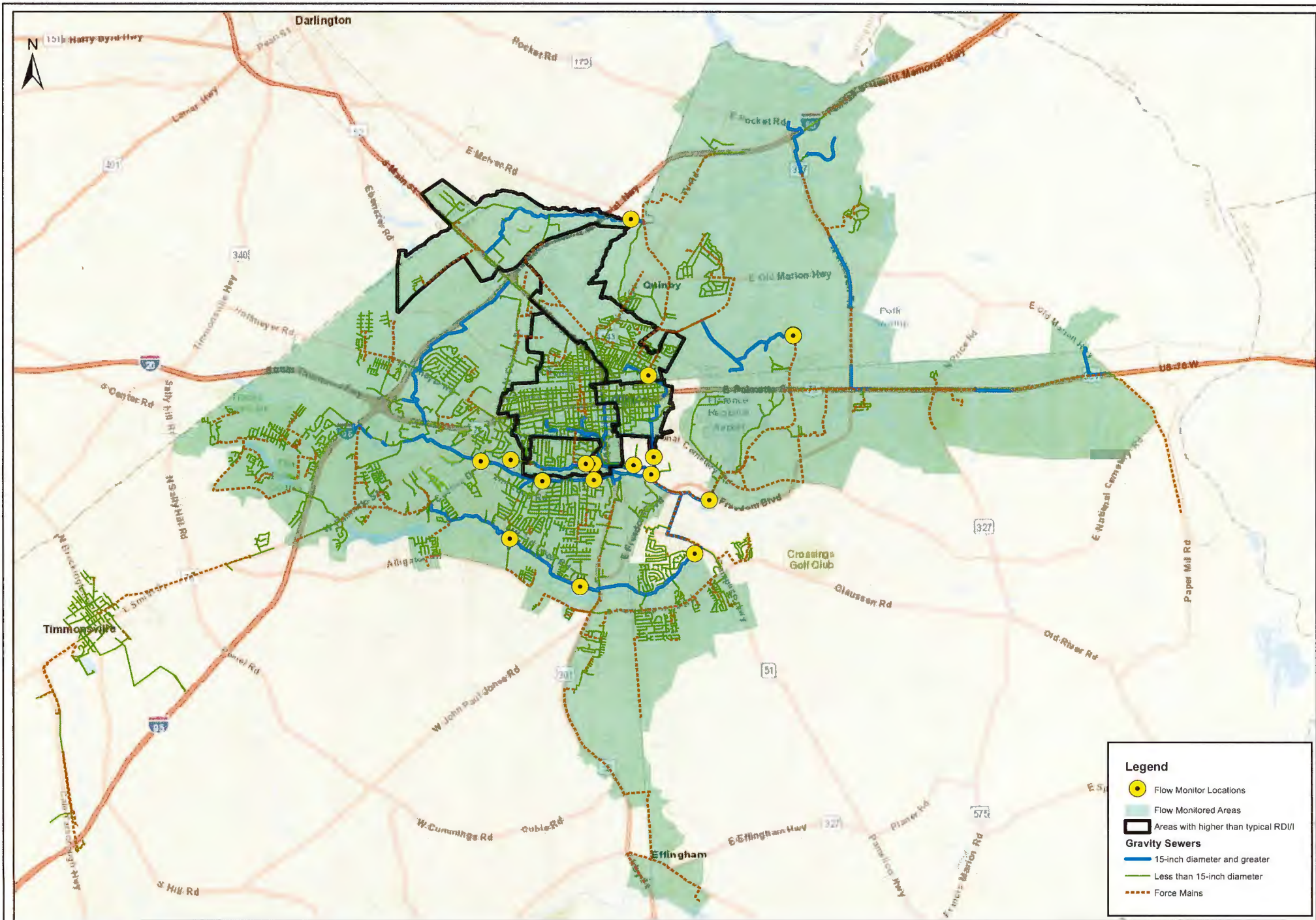

Figure 2
Flow Monitored Areas with Higher RD/I

The dry-weather wastewater flows recorded during the temporary flow monitoring were increased by a factor of 1.44 to represent average antecedent moisture conditions for the capacity analysis based on a comparison of historical wastewater effluent flow to effluent flow during the temporary flow monitoring period.

A peaking factor approach was used to simulate the design storm for the capacity analysis of the Jeffries Creek interceptor system. The most intense storm event recorded during the flow monitoring period had an average recurrence interval of less than 1-year. Typically, collection system improvements are designed to convey wastewater flows resulting from a larger storm event. Therefore, the wet-weather peaking factors observed during the temporary flow monitoring were increased by a factor of 1.92 to represent wastewater flows resulting from a larger storm event with a 2-year recurrence interval (i.e. 2-year storm event). The 1.92 escalation factor was determined based on a comparison of peak rainfall intensity during a 2-year storm event to the peak intensity of the largest storm event recorded during the temporary flow monitoring period.

3.3 Future Wastewater Flows

According to City staff, the majority of the central portion of Jeffries Creek basin is fully developed. However, potential for future growth exists in the western portion of the collection system, upstream of flow monitor JS1. According to the 2005 Pee Dee Regional Water and Sewer Master Plan, the baseline growth for sewer flows is projected at an annual rate of 1.56 percent. Therefore, for sizing improvements, the average dry-weather flows upstream of flow monitor JS1 were increased by 1.56 percent per year, from 1.6 mgd in 2012 to 1.9 mgd in 2025. Future peak flows were determined by applying a peaking factor similar to the adjusted peaking factor for the current area upstream of flow monitor JS1. In addition, a future pumped flow of 0.30 mgd from Darlington County is projected to enter the City of Florence collection system upstream of Jeffries Creek interceptors.

Since the original analysis of Jeffries Creek flows in 2012, the City has information projecting additional developments in the western Jeffries Creek basin, Pye Branch basin, and Middle Swamp basin. Additional growth in the western portion of the collection system could impact the recommendations for improvements to the Jeffries Creek interceptors presented in this study and should be evaluated prior to design of improvements.

4.0 Hydraulic Modeling and Capacity Analysis

4.1 Model Development and Calibration

Hydraulic modeling of the Jeffries Creek interceptor sewer system was performed using the PCSWMM modeling software. The physical information describing the collection system (manhole locations, rim elevations, invert elevations, pipe connectivity, and pipe sizes) was obtained through field survey conducted by URS and manhole inspection reports prepared by City staff from inspections conducted during the winter of 2011/2012. The hydraulic model includes approximately 12 miles of Jeffries Creek gravity interceptor sewers ranging from 12-inches to 42-inches in diameter extending from Woody Jones Boulevard to the FRWWMF. The model includes the interconnecting pipes between the northern and southern Jeffries Creek interceptors (approximately 6,200 feet of 8-inch through 18-inch diameter pipe) and branch collector sewers

up to one manhole upstream of the interceptor. The hydraulic model was calibrated to dry-weather and wet-weather flows recorded during the flow monitoring program so that it would accurately represent system hydraulics under existing conditions. The model calibrated to within 10% of monitored values.

4.2 Capacity Analysis

Once calibrated, the hydraulic model of the existing Jeffries Creek interceptors was run with adjusted dry-weather flows and adjusted peak wet-weather design flows to confirm existing capacity of the interceptors and determine areas that are susceptible to surcharging and/or overflows.

Figure 3 shows the pipe capacity used under peak dry-weather flow conditions, as calculated by comparing the depth of flow in the sewer to the diameter of the pipe. Typically, sewers flowing greater than 75 percent full during peak dry-weather are considered hydraulically deficient and will be recommended for improvements. The majority of the northern Jeffries Creek interceptor is less than 50 percent full, indicating adequate capacity for dry-weather flows. The upstream portion of the southern Jeffries Creek interceptor is 50 to 75 percent full, and the downstream portion is generally 75 to 100 percent full indicating limited capacity during peak dry-weather flow. Some slight surcharging is predicted on the southern interceptor in the vicinity of the Gully Branch diversion due to reverse grade slopes of some pipes in the area. The peak dry-weather flow to the influent pump station is 9.5 mgd. The firm capacity of the influent pump station is 42 mgd.

Typically, pipes with flow surcharging more than one foot above the crown of the pipe or within three feet of the manhole rim during peak design wet-weather flows are considered hydraulically deficient and will be recommended for improvements. Under peak wet-weather flow conditions, the entire southern interceptor from Woody Jones Boulevard to the FRWWMF is surcharged, as well as portions of the northern interceptor between Deberry Boulevard and the Gully Branch diversion. The surcharging is due to pipe capacity limitations. Multiple overflow locations are predicted during simulated wet-weather flows. Therefore, the majority of the Jeffries Creek interceptor system has insufficient capacity for design wet-weather flows.

Figure 4 presents a hydraulic profile of the northern Jeffries Creek interceptor under peak wet-weather design flow conditions showing surcharging above the pipe crown in some sections. **Figure 5** presents a hydraulic profile of the southern Jeffries Creek interceptor under peak wet-weather design flow conditions showing that the entire interceptor is fully surcharged and overflowing at the manholes with lowest rim elevation. While the model-predicted overflows are in the general vicinity of locations where wet-weather related overflows have been reported in the past along the southern interceptor, the hydraulic model assumes that the pipes are clean, therefore, any debris or obstructions in the pipe could affect the location of the predicted overflow relief points.



Legend

Peak Dry Weather Flow

Percent Pipe Full (Depth)

- Surcharged
- 75-100%
- 50-75%
- 25-50%
- 0-25%

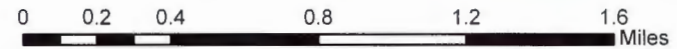

Figure 3
Peak Dry Weather Flow Capacity

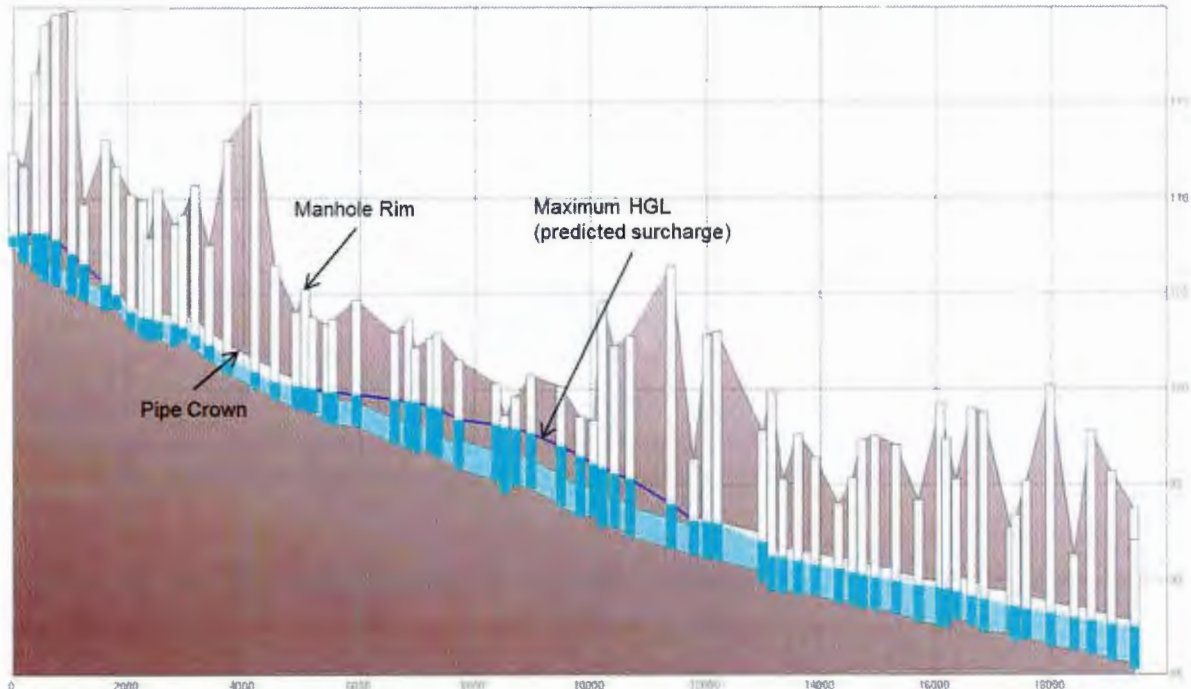

Figure 4. Hydraulic Profile of Northern Interceptor During Peak Wet-Weather Design Flow

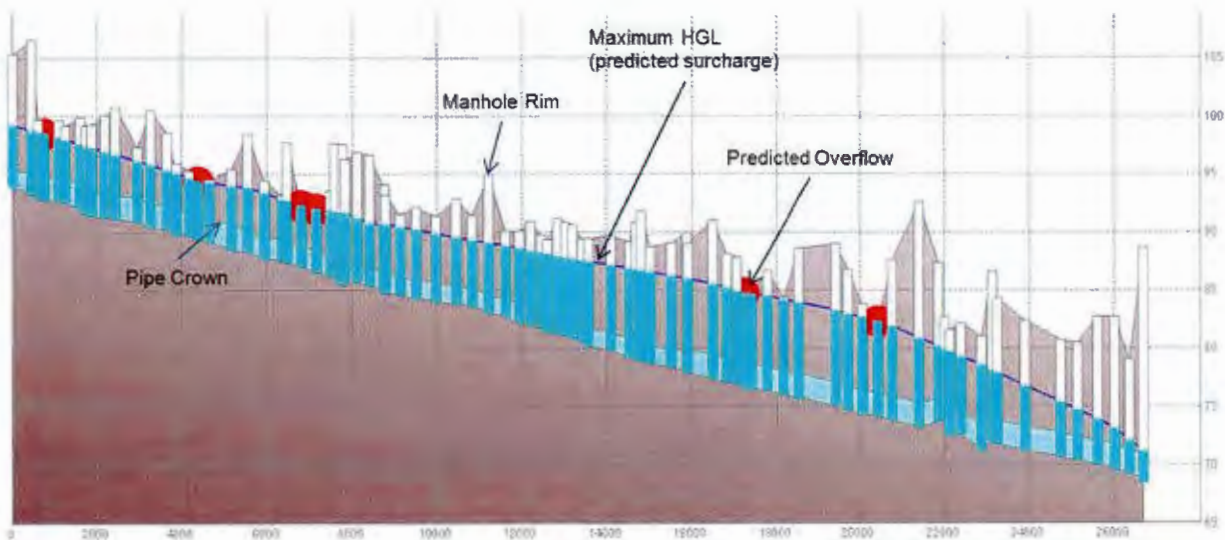

Figure 5. Hydraulic Profile of Southern Interceptor During Peak Wet-Weather Design Flow

The peak simulated wet-weather flow to the influent pump station is 29.6 mgd. However, the peak flow predicted at the pump station is not the true peak flow since some flow is being lost to overflows upstream. Assuming the overflows are corrected and no capacity limitations exist, the peak wet-weather flow conveyed to the influent pump station is 39.4 mgd which is less than the

42-mgd firm capacity of the renovated station and found to be reasonable and in line with previous predicted peak flows.

5.0 Improvement Alternatives

Hydraulic improvements were identified to address the capacity limitations of the existing Jeffries Creek interceptors. The proposed new facilities are sized to meet the following criteria for the projected future flows:

- Pipes flow less than 50 percent full during peak dry-weather flow
- Flow is contained within pipes during wet-weather (i.e., no surcharging)
- Pump station firm capacity is equal to the peak wet-weather flow
- Peak wet-weather flow velocity in force mains is between 5 to 10 feet per second

The construction cost estimates for the improvements were prepared at the “study estimate” level using previous estimates for similar projects, historical data from comparable work, and estimating guides and equipment costs. Factors such as competitive market conditions, geotechnical site conditions, easement acquisition, and implementation schedule cannot be quantified at the current level of detail but can significantly impact the project cost.

Costs presented for each alternative are based on unit costs for pipeline and pump station installation, which generally include labor, equipment, materials and other ancillary costs (mobilization, maintenance of traffic, site restoration, etc.). The gravity sewer unit costs include the cost of manhole installation. Costs do not include easement or land acquisition.

Total construction cost is calculated by applying a 30 percent contingency to the cost of pipeline and pump station installation. The capital costs are calculated by applying 15 percent to the total construction cost for engineering, legal, and administrative fees. All costs shown in the following sections are 2016 values.

Three general alternatives were identified, with variations on each. These include combinations of pipe upgrades, installation of parallel pipe, new pump station and force main, and pipeline rehabilitation.

5.1 Alternative 1 – Gravity Pipe Upsizing

Alternative 1 includes new replacement gravity pipes only. Pipe upgrades were simulated in the hydraulic model, starting at the downstream-most end of the southern Jeffries Creek interceptor, and progressing upstream until predicted overflows and surcharging were eliminated. The resulting improvements, as shown in **Figure 6**, include replacement of the entire southern interceptor from Woody Jones Boulevard to the FRWWMF with new 30-inch through 42-inch diameter pipeline. The last segment of sewer downstream of where the northern interceptor joins with the southern interceptor just before the influent pump station is recommended to be replaced with a new 48-inch diameter pipe (or paralleled with a 24-inch pipe). The parallel 18-inch diameter sewers from Cashua Drive to Edisto Drive are replaced with a new single 36-inch diameter pipe.

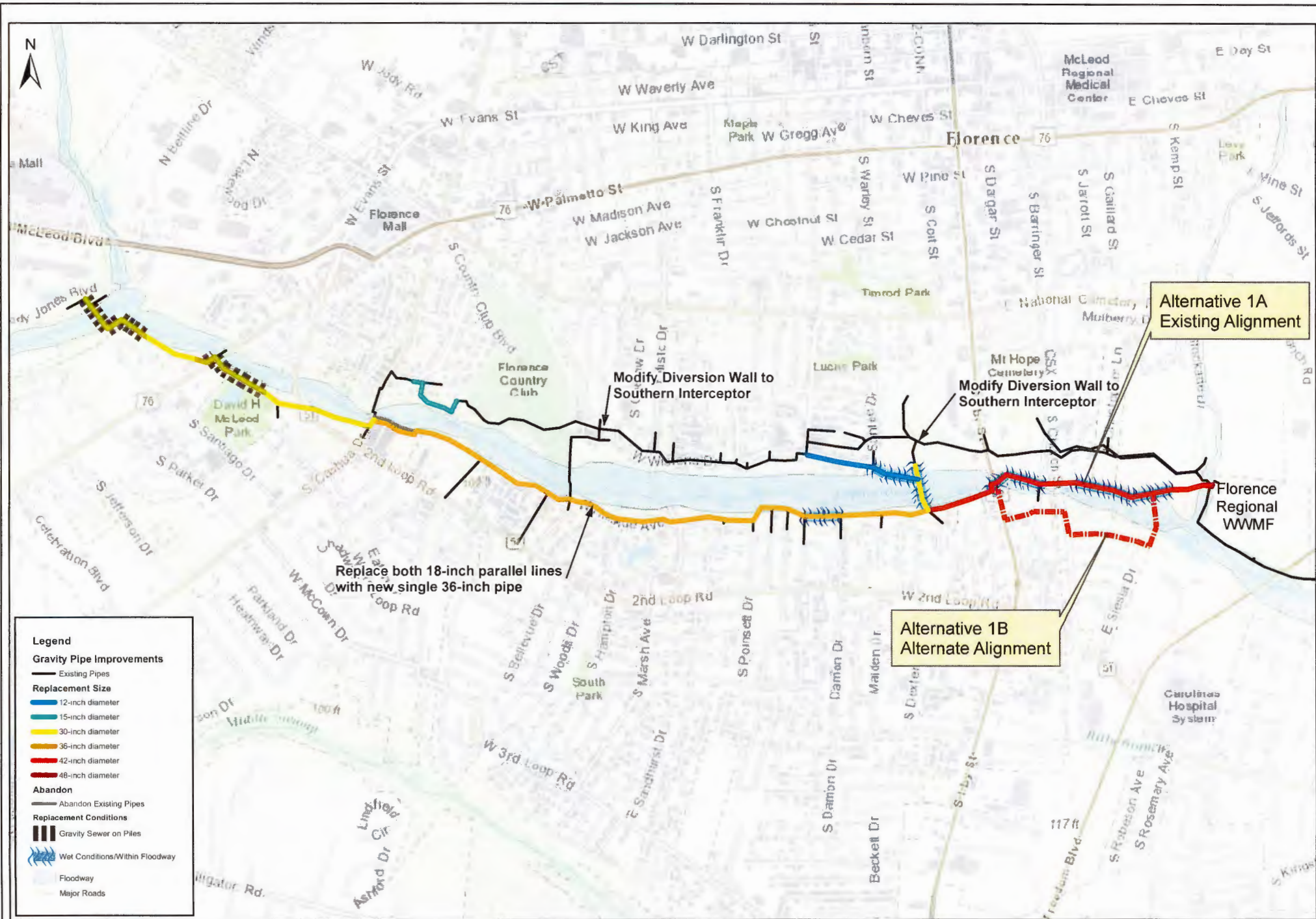

Figure 6
Alternative 1 - Gravity Pipe Upsizing

Two variations of Alternative 1 were evaluated (Figure 6). Alternative 1A includes pipe replacement along the existing alignment of the southern interceptor. Alternative 1B provides an alternate route for the replacement pipe downstream of Irby Street. While the 1B route is longer, it avoids some difficult construction along the wet, swampy area of the existing southern interceptor.

For both variations of Alternative 1, pipe replacement is recommended for the Gully Branch diversion sewer (30-inch diameter replacement) and adjacent sewer from Wisteria Drive (12-inch diameter replacement) since these pipes are also capacity-limited during peak design flows. Due to some surcharging during peak flows, the section of 12-inch diameter sewer on the northern interceptor behind several homes near Fairway Drive is replaced with a new 15-inch diameter pipe. The total length of gravity sewer replacement in Alternative 1A is approximately 6.0 miles. The total length of gravity sewer replacement in Alternative 1B is approximately 6.3 miles.

In addition to pipe replacement, the diversion walls at South Brunwood Drive (MH JFC-0640) and Gully Branch (MH GLB-0120) are modified to control the diversion of flow from the northern interceptor to the southern interceptor. The diversion wall at South Brunwood Drive is lowered to divert more wet-weather flow to the southern interceptor and thus, avoid upgrades on the northern interceptor. The manhole field inspection reports showed that the diversion wall at Gully Branch is deteriorated. This alternative includes rebuilding the diversion wall to keep more flow on the northern interceptor and allow use of the full capacity of the northern interceptor during peak design flow, thus reducing the replacement pipe size of the southern interceptor downstream of the Gully Branch diversion.

The older northern interceptor is not replaced as part of Alternative 1, and this pipe is suspected to be in poor condition. Therefore, it is recommended that the parallel 15-inch and 24-inch northern interceptor pipe be rehabilitated via cured-in-place pipe (CIPP) lining or other rehabilitation methods from Gully Branch to the FRWWMF as part of Alternative 1.

Cost

The majority of the southern interceptor is difficult to access and would require heavy clearing for the construction easement. These conditions were factored into the pipe installation unit costs for this alternative. As shown in Figure 6, several sections of existing pipe in the upstream portion of the project are installed on piling piers. For these sections, it is assumed that the replacement pipe would need to be installed on new piling piers, although geotechnical investigation would be performed in the design phase of the project to confirm the required installation for the pipe. Several sections of replacement pipe are located in areas with standing water and/or within the Jeffries Creek floodway. For these areas, it is assumed that heavy dewatering will be required for pipe installation. Creek crossings of Jeffries Creek are assumed to be performed using trenchless methods. Major road and railroad crossings are assumed to be installed using jack-and-bore methods. New manholes on the southern interceptor (included in the pipe installation unit cost) would be installed with rims above the 100-year flood water surface elevation. Costs also include CIPP lining of approximately 3,200 linear feet of the northern interceptor. The total capital cost estimate for Alternative 1A is \$34.0 million. The total capital cost estimate for Alternative 1B is \$34.9 million. Alternative 1A and 1B are the most expensive alternatives examined in this study.

Non-Cost Factors

The main advantages of Alternative 1 include:

- The southern interceptor is replaced with all new pipe and manholes, which will reduce I/I from Jeffries Creek.
- Approximately 3,200 linear feet of the oldest section of the northern interceptor is structurally rehabilitated to reduce the risk of SSOs in the future.
- The all-gravity sewer alternative has lower operation and maintenance costs as compared with pumping alternatives.

The main disadvantages of Alternative 1 include:

- Pipe replacement along the existing alignment involves significant environmental disturbance along Jeffries Creek.
- Conditions along the southern interceptor are difficult for construction and include requirement of heavy dewatering in some areas and a long creek crossing at Gully Branch.
- Documented easements for the existing sewer are not available. Therefore, construction of replacement sewers would require easement acquisition.

5.2 Alternative 2 – Pump to Northern Interceptor

Alternative 2 involves construction of a new pump station and force main to pump wastewater flow from the upstream portion of the Jeffries Creek interceptors to the downstream portion of the northern interceptor to avoid gravity sewer replacement along the southern interceptor. Additional flow is removed from the southern interceptor by abandoning the Gully Branch diversion to the south. This avoids pipe upgrades through wet conditions around the downstream portion of the southern interceptor, but requires pipe upgrades on the downstream portion of the northern interceptor where construction access is easier.

The entire interconnecting sewer between the northern and southern interceptors at Gully Branch can be abandoned if a small lift station and 4-inch diameter force main is installed to pump wastewater flow from several low-lying homes adjacent to Wisteria Drive back up to the northern interceptor. Abandoning the interconnecting sewer would also reduce I/I from Jeffries Creek into the sanitary sewer system.

Several variations of this alternative were evaluated with differing pump station locations, force main routing, and force main discharge locations, as listed in **Table 1** and shown on **Figure 7**. In general, all of the Alternative 2 variations include a 30-inch diameter replacement gravity sewer from Woody Jones Boulevard to US 76/Palmetto Street, 30 or 36-inch diameter replacement gravity sewer from US 76/Palmetto Street to the new pump station, an 18-inch diameter force main, and replacement of the northern interceptor from the force main discharge to the influent pump station. The northern interceptor section of parallel 15-inch and 27-inch diameter sewer downstream of Gully Branch is replaced with new single 42-inch diameter pipeline.

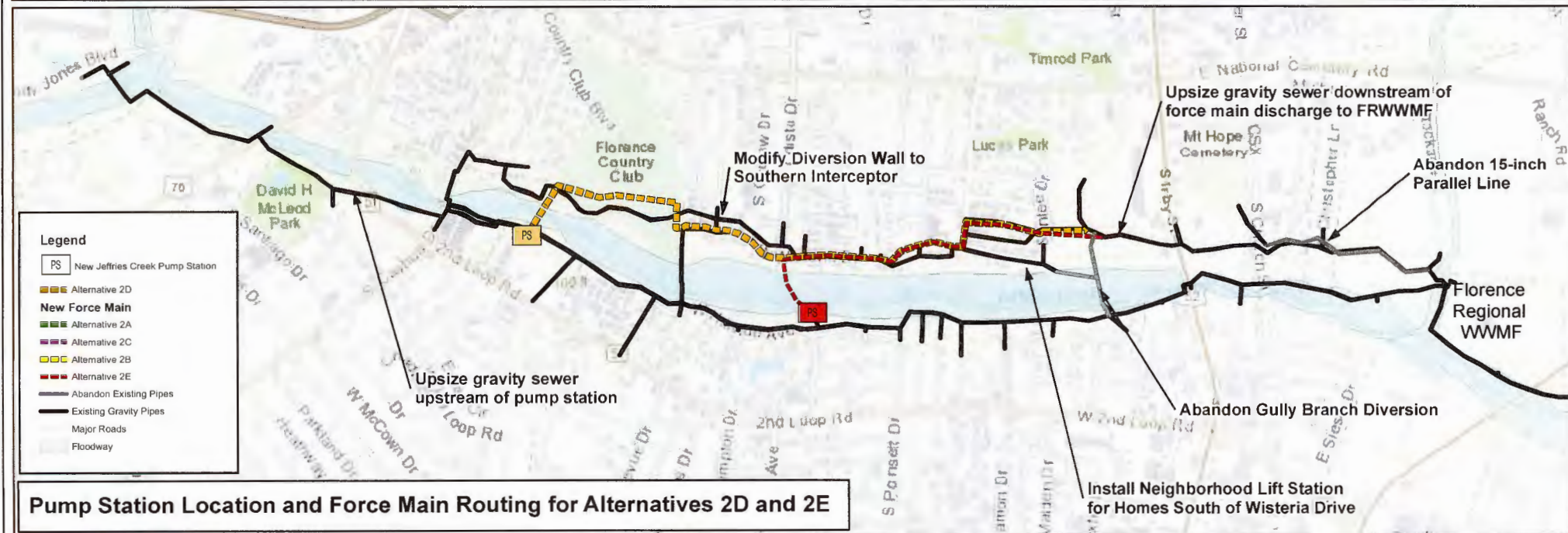
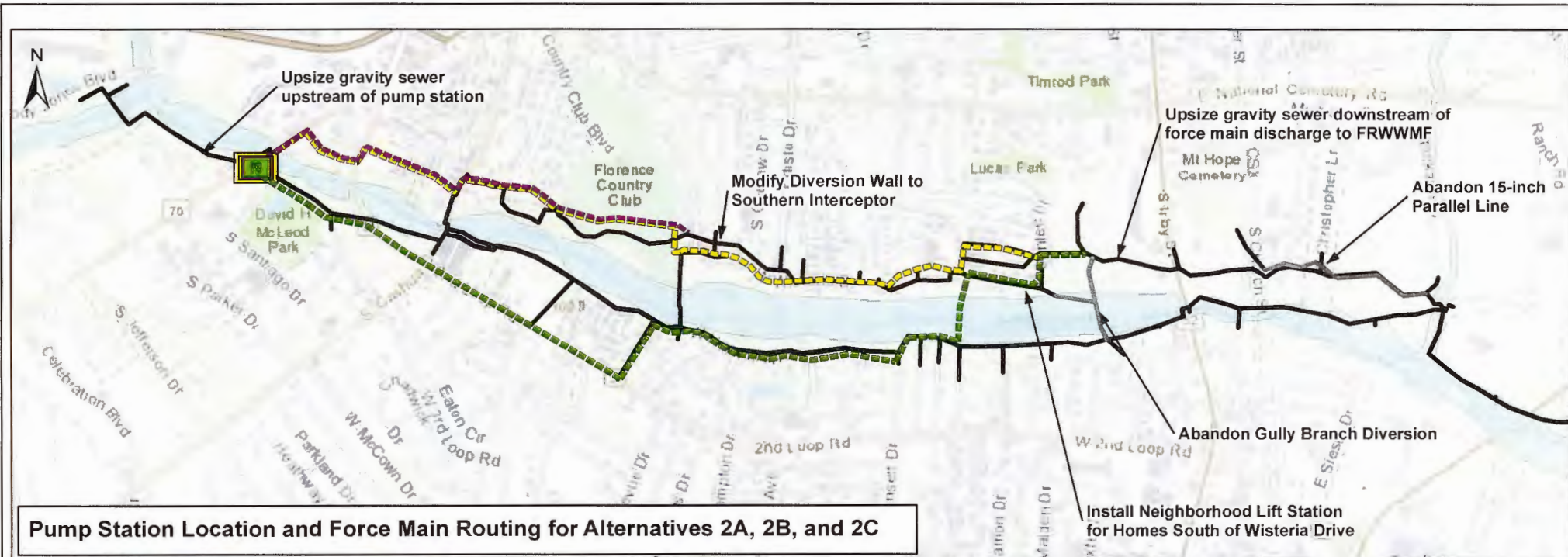

Table 1. Alternative 2 Variations on Pump Station Location, Force Main Routing, and Length of Gravity Sewer Replacement

Alt	Pump Station Location/ Capacity	Force Main Route	Force Main Discharge	Force Main Length	Gravity Sewer Replacement Length
2A	US 76/ Palmetto Street 8.1 mgd	South side of Jeffries Creek along Second Loop Road and existing interceptor; crosses Jeffries Creek at the end of South Rollins Avenue; north side of Jeffries Creek along Wisteria Drive to northern interceptor.	Northern interceptor downstream of Gully Branch	3.9 miles	2.5 miles
2B	US 76/ Palmetto Street 8.1 mgd	Crosses Jeffries Creek at US 76; north side of Jeffries Creek along Holly Circle to Woodland Drive and Fairway Drive, continuing across the Florence Country Club golf course and along Wisteria Drive to northern interceptor.	Northern interceptor downstream of Gully Branch	3.2 miles	2.5 miles
2C	US 76/ Palmetto Street 8.1 mgd	Crosses Jeffries Creek at US 76; north side of Jeffries Creek along Holly Circle to Woodland Drive and Fairway Drive, continuing across the Florence Country Club golf course to northern interceptor.	Northern interceptor downstream of Florence Country Club	1.7 miles	3.8 miles
2D	Near Cypress Point Drive 10.1 mgd	Crosses Jeffries Creek near Cypress Point Drive; north side of Jeffries Creek across the Florence Country Club golf course and along Wisteria Drive to northern interceptor.	Northern interceptor downstream of Gully Branch	2.2 miles	3.3 miles
2E	Edisto Drive 11.1 mgd	Crosses Jeffries Creek at Edisto Drive; north side of Jeffries Creek along Wisteria Drive to northern interceptor.	Northern interceptor downstream of Gully Branch	1.4 miles	4.3 miles

The last segment of sewer downstream of where the northern interceptor joins with the southern interceptor just before the influent pump station is recommended to be replaced with a new 48-inch diameter pipe (or paralleled with a 24-inch pipe).

Due to some surcharging during peak flows, the section of 12-inch diameter sewer on the northern interceptor behind several homes near Fairway Drive is replaced with a new 15-inch diameter pipe in Alternatives 2A, 2B, and 2C. The section of 18-inch diameter sewer on the northern interceptor between Wisteria Drive and Oleander Drive is replaced with a new 24-inch diameter pipe for all Alternative 2 variations.

In addition to pipe replacement, the diversion wall at South Brunwood Drive (MH JFC-0640) is lowered slightly to divert more wet-weather flow to the southern interceptor and thus, avoid upgrades on the intermediate section of the northern interceptor. To reduce I/I from Jeffries Creek into the existing southern interceptor, it is recommended that manhole rims along the Jeffries Creek interceptors be raised above the 100-year flood water surface elevation.

It should be noted that the variations of this alternative with the pump station located at US 76/Palmetto Street (2A, 2B, and 2C) still result in some surcharging during peak wet-weather flows within the southern interceptor, as shown in **Figure 8**. However, surcharging is not predicted to be within 3 feet of the manhole rim and no overflows are predicted. Surcharging is eliminated with the pump located further downstream (and thus diverting more flow to the northern interceptor) for Alternatives 2D and 2E.

The southern interceptor is not replaced under Alternative 2. Since there is a high potential for I/I from Jeffries Creek along the existing southern interceptor, it is recommended that the condition of this pipe be assessed and pipe lining or other rehabilitation be performed as needed, as a follow-up phase to this alternative.

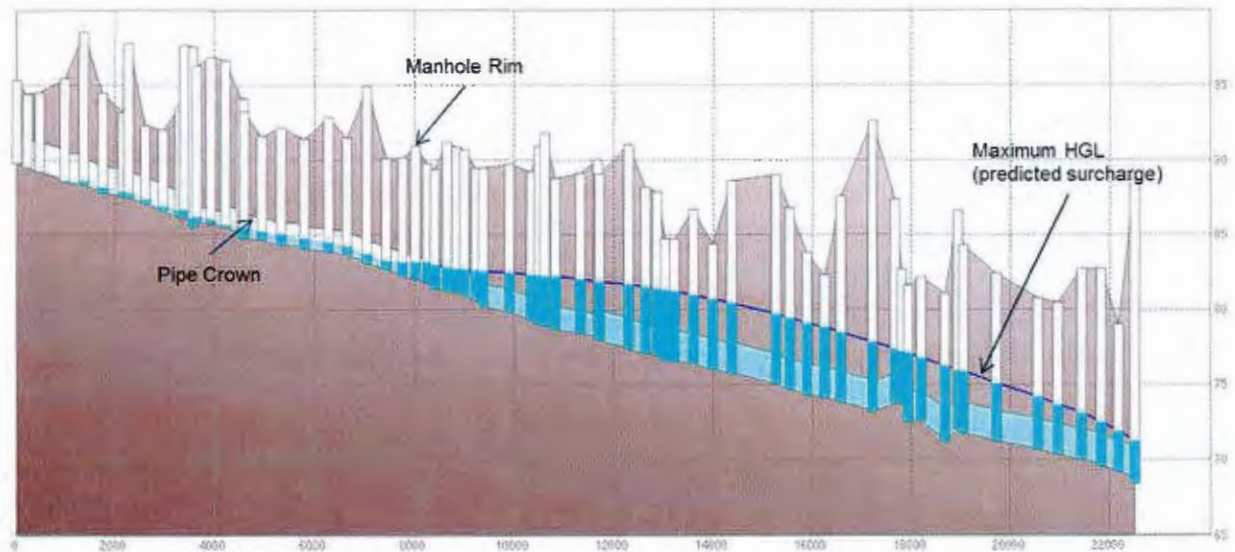

Figure 8. Hydraulic Profile of Southern Interceptor Downstream of New Pump Station during Peak Wet-Weather Design Flow (Alternatives 2A, 2B, and 2C)

Cost

Several sections of existing pipe in the upstream portion of the project are installed on piling piers. For these sections, it is assumed that the replacement pipe would need to be installed on new piling piers, although geotechnical investigation would be performed in the design phase of the project to confirm the required installation for the pipe. Creek crossings of Jeffries Creek are assumed to be performed using trenchless methods. Major road and railroad crossings are assumed to be installed using jack-and-bore methods. The new pump station is assumed to be a submersible pump station including three pumps with variable frequency drives. Alternative 2 costs do not include rehabilitation of the southern interceptor. The condition of this pipeline is unknown and should be assessed after Alternative 2 improvements are made. The total capital cost estimate for Alternative 2 variations is given in **Table 2**.

Table 2. Alternative 2 Capital Costs

Alternative	Capital Cost Estimate
2A	\$23,400,000
2B	\$21,900,000
2C	\$23,200,000
2D	\$22,900,000
2E	\$26,500,000

Non-Cost Factors

The main advantages of Alternative 2 include:

- Construction through environmentally sensitive areas along the southern interceptor is avoided.
- The replacement gravity sewer upstream of the new Jeffries Creek pump station can be installed deeper, which would eliminate the at-grade stream crossing near Woody Jones Boulevard and may possibly eliminate the need for installation on pilings.
- Some of the oldest sections of the Jeffries Creek interceptors – the 27-inch diameter VCP pipe installed in the 1950's and the pre-1950's parallel 15-inch diameter pipe on the northern interceptor – are replaced as part of this alternative.
- The Gully Branch interconnecting sewer between the northern and southern interceptors, which is located through an area of standing water, can be abandoned to reduce I/I from Jeffries Creek into the sanitary sewer.

The main disadvantages of Alternative 2 include:

- The new pump station has higher operation and maintenance costs than an all gravity sewer alternative.
- Long force main associated with the new Jeffries Creek pump station will require special attention to corrosion and odor control measures.
- The southern interceptor still experiences some surcharging during peak wet-weather design flow for Alternatives 2A, 2B, and 2C, but this is not a disadvantage for Alternatives 2D and 2E, which replace the interceptor at this surcharge location.
- Since there is a high potential for I/I from Jeffries Creek along the existing southern interceptor, it is recommended that the condition of this pipe be assessed and pipe lining or other rehabilitation be performed as needed, as a follow-up phase to this alternative. The cost estimate does not include the cost of this rehabilitation, which will be required in the future.

Preferred Alternative 2 Variation

Alternative 2E was selected as the preferred variation of Alternative 2 due to the availability of land at Edisto Drive for locating a pump station and because this alternative minimizes the length of the force main. Surcharging along the southern interceptor is also eliminated with Alternative 2E. The Alternative 2E improvements are shown in **Figure 9**.

5.3 Alternative 3 – Pump to FRWWMF

Alternative 3 involves pumping wastewater flow from the upstream portion of the Jeffries Creek interceptors to avoid gravity sewer replacement along the southern interceptor, similar to Alternative 2. However, the force main extends all the way to the FRWWMF.

As shown in **Figure 10**, a new pump station with firm capacity of 11.1 mgd is located at Edisto Drive and an 18-inch diameter force main is routed along the existing southern interceptor from the pump station to Irby Street. At Irby Street, the force main is routed to the south to avoid the wet, swampy conditions along the existing southern interceptor. The force main crosses Jeffries Creek behind the Freedom Florence ball fields and continues to the FRWWMF influent pump station. The total length of the new 18-inch diameter force main in Alternative 3 is 2.7 miles.

Other recommended improvements are the same as those in Alternative 2E:

- The gravity sewer on the southern interceptor upstream of the pump station is replaced with a new 30-inch pipeline from Woody Jones Boulevard to Cashua Drive, increasing to 36-inch diameter from Cashua Drive to Edisto Drive.
- The connection between the 18-inch diameter sewer on Cashua Drive and the northern interceptor at Fairway Drive is abandoned to direct flow south to the new pump station.
- The entire interconnecting sewer between the northern and southern interceptors at Gully Branch is abandoned and a small lift station and 4-inch diameter force main is installed to pump wastewater flow from several low-lying homes adjacent to Wisteria Drive back up to the northern interceptor.
- Due to surcharging, the section of 18-inch diameter sewer on the northern interceptor between Wisteria Drive and Oleander Drive is replaced with a new 24-inch diameter pipe.
- In addition to pipe replacement, the diversion wall at South Brunwood Drive (MH JFC-0640) is lowered slightly to divert more wet-weather flow to the southern interceptor and thus, avoid upgrades on the intermediate section of the northern interceptor.
- To reduce I/I from Jeffries Creek into the existing southern interceptor, it is recommended that manhole rims along the Jeffries Creek interceptors be raised above the 100-year flood water surface elevation.
- Although flow is not pumped to the northern interceptor, more flow is routed along the northern interceptor with the abandonment of the Gully Branch connection. To provide additional capacity for this flow, the northern interceptor section of parallel 15-inch and 27-inch diameter sewer downstream of Gully Branch is replaced with new single 36-inch diameter pipeline.

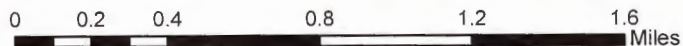
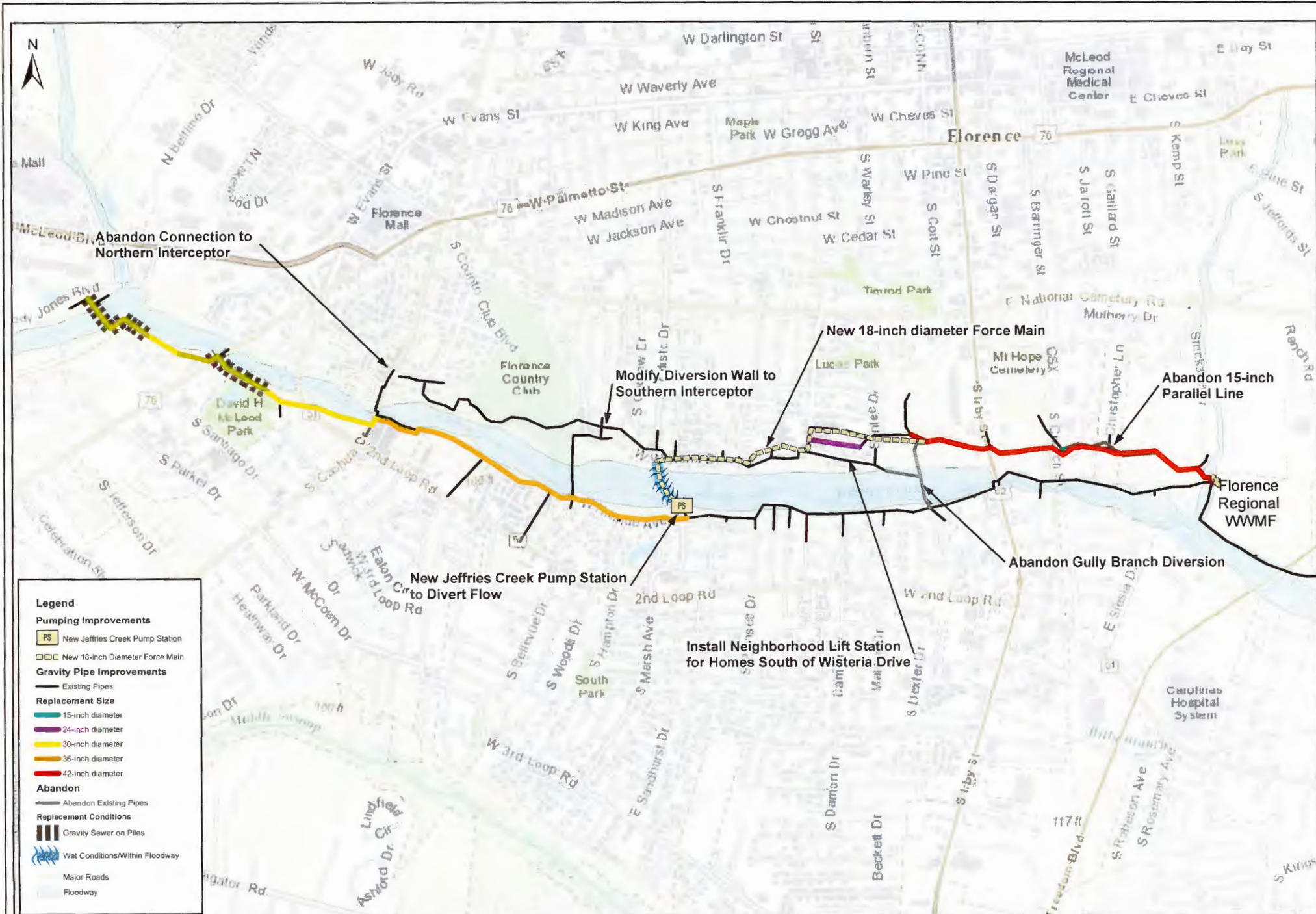
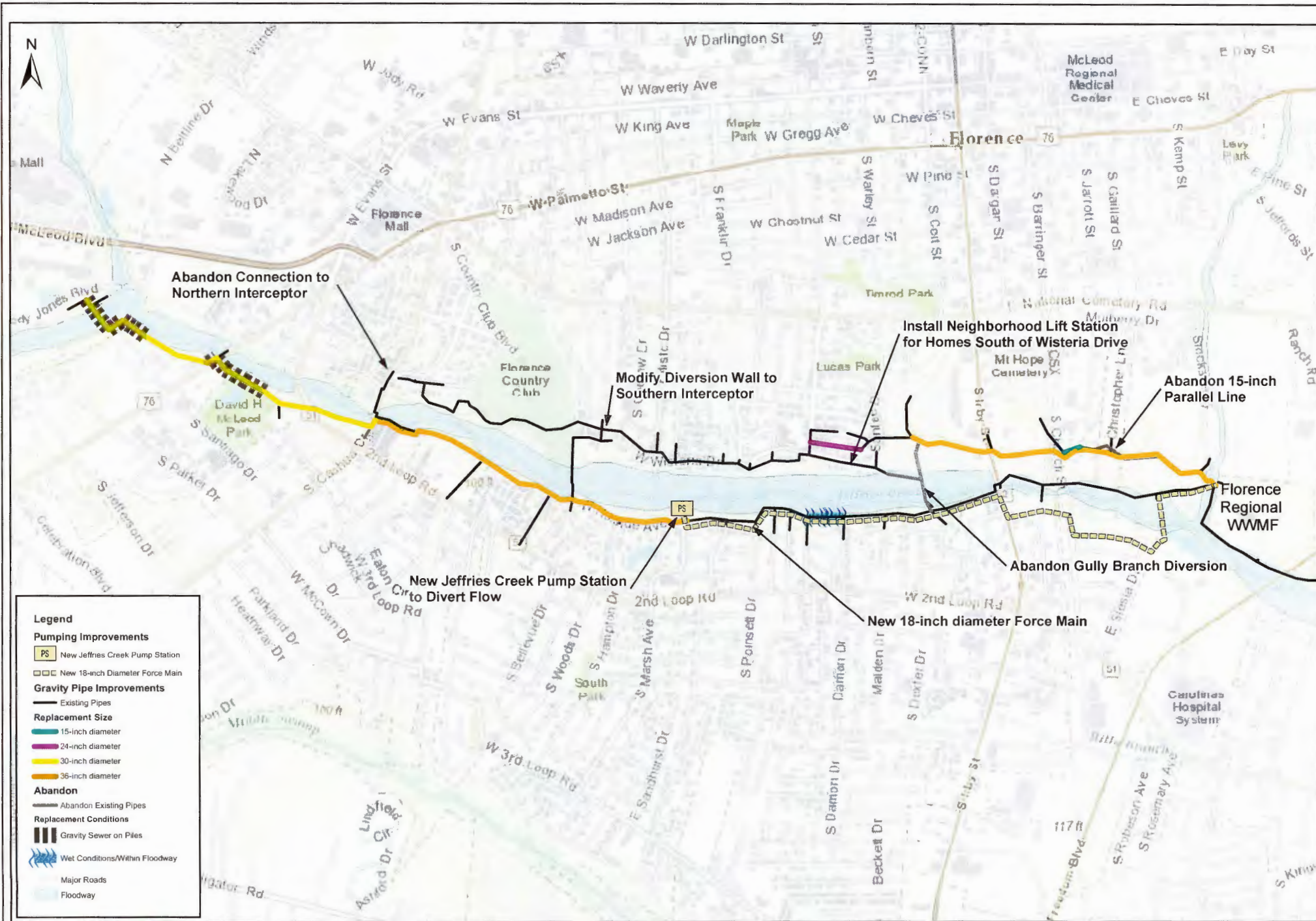

Figure 9
Alternative 2E - Preferred Option for Pumping to Northern Interceptor



Abandon Connection to Northern Interceptor

Modify Diversion Wall to Southern Interceptor

Install Neighborhood Lift Station for Homes South of Wisteria Drive

Abandon 15-inch Parallel Line

New Jeffries Creek Pump Station to Divert Flow

Abandon Gully Branch Diversion

New 18-inch diameter Force Main

Florence Regional WWMF

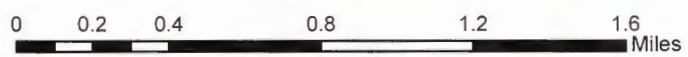

Figure 10
Alternative 3 - Pump to Florence Regional WWMF

Cost

Several sections of existing pipe in the upstream portion of the project are installed on piling piers. For these sections, it is assumed that the replacement pipe would need to be installed on new piling piers, although geotechnical investigation would be performed in the design phase of the project to confirm the required installation for the pipe. Creek crossings of Jeffries Creek are assumed to be performed using trenchless methods. Major road and railroad crossings are assumed to be installed using jack-and-bore methods. The new pump station is assumed to be a submersible pump station including three pumps with variable frequency drives. The total capital cost estimate for Alternative 3 is \$27.0 million.

Non-Cost Factors

When compared with the Alternative 1 pipe replacement only, Alternative 3 generally has the same advantages and disadvantages as Alternative 2. The main advantage of Alternative 3 over Alternative 2 is that a first phase (pump station and force main) could be constructed to convey flow all the way to the FRWWMF.

The main disadvantage of Alternative 3 as compared to Alternative 2 is the longer force main that will require special attention to corrosion and odor control measures.

6.0 Phasing and Evaluation of Preferred Alternatives

Alternatives 1B, 2E, and 3 were selected as the preferred alternatives and were further evaluated and phased to select the recommended alternative.

6.1 Preliminary Phasing

The improvements for each preferred alternative were split into three phases as follows:

- Phase 1 projects were selected to address capacity limitations and predicted overflows from the Gully Branch diversion and southern interceptor downstream of Edisto Drive.
- Phase 2 projects include all additional recommended improvements for both the northern and southern interceptors downstream of Cashua Drive.
- Phase 3 projects include recommended improvements upstream of Cashua Drive.

Figures 11, 12, and 13 show preliminary phasing for Alternatives 1B, 2E, and 3, respectively.

6.2 Alternatives Evaluation

The three preferred alternatives were scored and ranked based on cost and non-cost factors. The evaluation was primarily focused on the first phase of improvements for each alternative. The following nine factors were considered and scored from 1 to 5, with 1 being the least favorable and 5 being the most favorable.

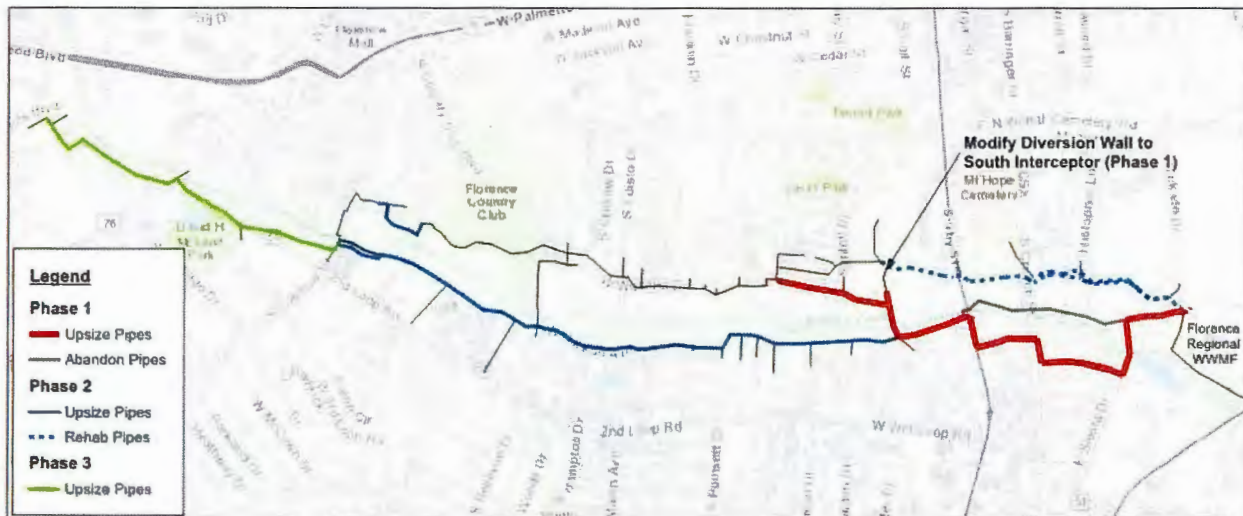

Figure 11. Alternative 1B Phasing

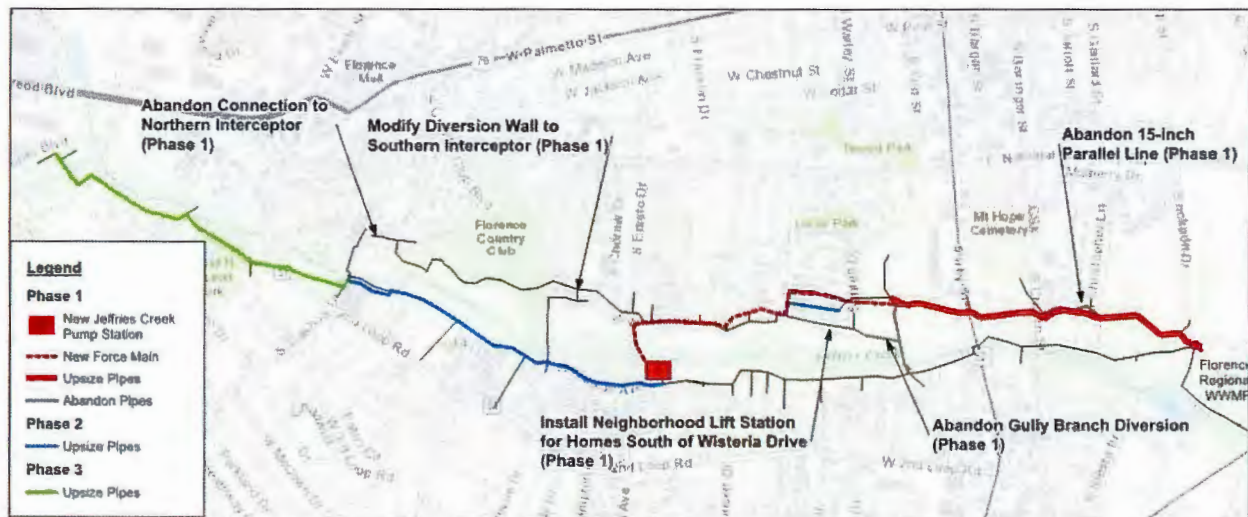

Figure 12. Alternative 2E Phasing



Figure 13. Alternative 3 Phasing

- **Regulatory Compliance** – This factor is scored based on the relative decrease in model-predicted SSO volume after phase 1 improvements are complete.
- **Capacity** – This factor is scored based on the remaining length of pipe that is predicted to experience surcharging after phase 1 improvements are complete.
- **I/I Reduction** – This factor is scored based on the length of pipe that is replaced under phase 1 improvements.
- **Phase 1 Capital Cost** – This factor is scored based on the capital cost for phase 1 improvements.
- **30-Year O&M Cost** – This factor is scored based on the pump station and force main operations and maintenance costs over a 30-year period for phase 1 improvements.
- **Overall Capital Cost** – This factor is scored based on the total capital costs for phase 1, 2, and 3 improvements.
- **Community Impact** – This factor is scored based on relative disruption of backyards/homes for the phase 1 improvements.
- **Environmental Impact** – This factor is scored based on relative disruption to the Jeffries Creek buffer area for the phase 1 improvements.
- **Alignment with Long-Term Solution** – This factor is scored based on relative percentage of the overall work for each alternative that is accomplished in phase 1, using the capital cost of phase 1 compared to the overall capital cost.

A workshop was held with CDM Smith and City staff to finalize the evaluation. Each factor was scored from 1 to 5, with 1 being the least favorable and 5 being the most favorable. Each factor was then given a weighing based on the importance to the overall score. The final evaluation matrix is given in **Table 3**. Alternative 2E was determined to be the most favorable alternative, with a total score of 35 out of 50 points.

Table 3. Alternatives Evaluation Matrix

Alternative		Alt 1B	Alt 2E	Alt 3
Description		Gravity Pipe Upsize	Pump to Northern Interceptor	Pump to FRWWMF
Phase 1 Capital Cost		\$15,400,000	\$15,000,000	\$9,100,000
Overall Capital Cost (Phase 1, 2, 3)		\$34,900,000	\$26,500,000	\$27,000,000
30-Year O&M Cost for Pumping & Force Main (Net Present Cost)*		\$0	\$1,450,000	\$1,650,000
Factor	Weight (%)	Score	Score	Score
Regulatory Compliance	15%	1	3	3
Capacity	10%	3	5	1
I/I Reduction	15%	5	3	1
Phase 1 Capital Cost	10%	3	3	5
30-Year O&M Cost	10%	5	1	1
Overall Capital Cost	10%	1	3	3
Community Impact	10%	1	4	1
Environmental Impact	10%	1	5	3
Alignment with Long-Term Solution	10%	3	5	1
Total Score (out of 50)		26	35	21

***Notes:**

Force main O&M includes: ARV inspection/ maintenance (24 man hours annually); ARV replacement every 10 years (1/2 of ARVs replaced); easement clearing every 5 years.

Pump Station O&M includes: Electrical costs based on horsepower and run time; operational labor based on 8 man hours per week; management labor based on 1-man hour per week; maintenance cost based on 1% of construction cost per year.

Interest rate = 3.0%; labor inflation = 2.6%; parts inflation = 2.4%; electrical power = \$0.07/kWh

7.0 Recommendations and Additional Considerations

Based on input from the City staff and evaluation of cost and non-cost factors, the final recommended alternative for the Jeffries Creek interceptor improvements is Alternative 2E. This alternative includes a new pump station near Edisto Drive to pump flow from the capacity-limited southern interceptor to the northern interceptor and improvements to increase the capacity of the northern interceptor.

7.1 Recommended Phase 1 Projects

Pending funding availability in the City's CIP, the recommended Phase 1 improvements may be further divided into two smaller projects as follows:

Phase 1A

- Install approximately 7,000 linear feet of new 42-inch diameter gravity sewer to replace the existing northern interceptor from Gully Branch to the FRWWMF.
- Abandon old 15-inch diameter parallel northern interceptor and connect flow to the new 42-inch pipe.
- Install a new lift station and approximately 700 linear feet of new 4-inch force main to pump flow from several homes at Wisteria Drive and Santee Drive to the northern interceptor.
- Abandon Gully Branch interconnection from the northern interceptor to the southern interceptor.

Estimated Capital Cost: \$8,000,000 (to be confirmed following preliminary design)

Phase 1B

- Construct new Jeffries Creek pump station along the southern interceptor near Edisto Drive (approximately 11 mgd).
- Install approximately 7,500 linear feet of new 18-inch diameter force main from the Jeffries Creek pump station to the northern interceptor.
- Modify northern interceptor diversion wall at Deberry Avenue to send additional flow to the southern interceptor for pumping.
- Abandon connection to the northern interceptor at Cashua Drive and Fairway Drive.

Estimated Capital Cost: \$7,000,000 (to be confirmed following preliminary design)

7.2 Additional Considerations

The following are additional recommendations that should be considered as the Jeffries Creek projects move into the design phase.

- The recommended improvement does not include pipe replacement along the southern interceptor due to difficulties and costs involved with constructing a new pipeline along the south side of Jeffries Creek. However, there is still a high potential for I/I from Jeffries Creek as well as structural failure along the existing southern interceptor, which is approaching 50 years old. After implementing the new Jeffries Creek pump station to remove a portion of the flow from the southern interceptor, it is recommended that the City perform CCTV inspection or other condition assessment to determine the condition of the existing interceptor. It is recommended that pipe lining or other rehabilitation be performed as needed to restore the condition and limit I/I entering the southern interceptor.
- The City does not have documented easements for the Jeffries Creek sewer interceptors. Obtaining easements for the existing Jeffries Creek interceptors will take a significant effort and may take quite some time to achieve based on available City funds and legal challenges on a property specific basis. However, it is recommended that City's ultimate goal should be to have permanent easements for its collection system. Portions of the southern interceptor

are also difficult to access. The City should aim to improve access for repairs and maintenance and also to reduce the risk and consequences of a line failure.

- The majority of the potential growth area in the City is located upstream of the proposed Jeffries Creek pump station. The evaluation performed for this study assumed baseline growth for sewer flows upstream of the modeled trunk sewer at an annual rate of 1.56 percent, resulting in a flow increase of approximately 0.3 mgd. However, the City has additional information regarding future development on the western side of the system. Therefore, up to date future flow projections and potential routing of flows for new developments in this area should be confirmed and refined during preliminary design of the Jeffries Creek pump station and pipelines.
- It is recommended that updated flow monitoring and the hydraulic model be used in the future to verify that the final project alignments convey flows as expected.





PEE DEE RIVER REGIONAL WATER TREATMENT PLANT
CONDITION ASSESSMENT AND EXPANSION

ENGINEERING REPORT

December 2020

DRAFT

Submitted by:

**CDM
Smith**

Table of Contents

Section 1 Introduction	1-1
1.1 Project Background	1-1
1.2 Overview of Existing Facilities	1-1
1.3 Organization of Report	1-1
Section 2 Condition Assessment	2-1
2.1 Methodology	2-1
2.1.1 Physical Facilities	2-1
2.1.2 Level of Priority	2-1
2.1.3 Functional Category	2-2
2.1.4 General Information and Properties	2-2
2.2 Condition Observations	2-3
2.2.1 Raw Water Pump Station No. 1	2-3
2.2.1.1 Process Equipment	2-4
2.2.1.2 Electrical Equipment	2-5
2.2.1.3 Building Architectural & Structural	2-5
2.2.1.4 Building Mechanical	2-6
2.2.1.5 Instrumentation & Control	2-6
2.2.1.6 Summary of Priority Projects	2-6
2.2.2 Raw Water Pump Station No. 2 and Reservoir	2-7
2.2.2.1 Process Equipment	2-7
2.2.2.2 Electrical Equipment	2-8
2.2.2.3 Building Architectural & Structural	2-8
2.2.2.4 Building Mechanical	2-8
2.2.2.5 Instrumentation & Control	2-9
2.2.2.6 Summary of Priority Projects	2-9
2.2.3 Treatment Process Train	2-9
2.2.3.1 Process Equipment	2-9
2.2.3.2 Electrical Equipment	2-10
2.2.3.3 Building Architectural & Structural	2-10
2.2.3.4 Instrumentation & Control	2-11
2.2.3.5 Summary of Priority Projects	2-11
2.2.4 Transfer Pump Station and Ground Storage Tank	2-11
2.2.4.1 Process Equipment	2-12
2.2.4.2 Electrical Equipment	2-12
2.2.4.3 Instrumentation & Control	2-13
2.2.4.4 Summary of Priority Projects	2-13
2.2.5 Finished Water Pump Station	2-13
2.2.5.1 Process Equipment	2-13
2.2.5.2 Electrical Equipment	2-14
2.2.5.3 Building Architectural & Structural	2-14
2.2.5.4 Building Mechanical	2-15
2.2.5.5 Instrumentation & Control	2-15

2.2.5.6 Summary of Priority Projects	2-15
2.2.6 Recycle Pump Station	2-16
2.2.6.1 Process Equipment	2-16
2.2.6.2 Structural	2-16
2.2.6.3 Instrumentation & Control	2-16
2.2.6.4 Summary of Priority Projects	2-17
2.2.7 Operations Building – Ground Level	2-17
2.2.7.1 Electrical Equipment.....	2-17
2.2.7.2 Building Architectural & Structural.....	2-18
2.2.7.3 Building Mechanical	2-19
2.2.7.4 Instrumentation & Control	2-20
2.2.7.5 Summary of Priority Projects	2-21
2.2.8 Operations Building – Basement Level	2-21
2.2.8.1 Process Equipment	2-21
2.2.8.2 Building Architectural & Structural.....	2-22
2.2.8.3 Building Mechanical	2-22
2.2.8.4 Instrumentation & Control	2-22
2.2.8.5 Summary of Priority Projects	2-22
2.2.9 Operations Building - Chemical Storage.....	2-23
2.2.9.1 Process Equipment	2-23
2.2.9.2 Electrical Equipment.....	2-25
2.2.9.3 Building Architectural & Structural.....	2-25
2.2.9.4 Building Mechanical	2-26
2.2.9.5 Instrumentation & Control	2-27
2.2.9.6 Summary of Priority Projects	2-27
2.3 Results.....	2-28
Section 3 Plant Expansion	3-1
3.1 Raw Water Pump Station No. 1	3-1
3.1.1 Process Equipment.....	3-1
3.1.2 Building Mechanical.....	3-2
3.1.3 Instrumentation & Control.....	3-3
3.1.4 Electrical.....	3-3
3.2 Raw Water Pump Station No. 2 and Reservoir.....	3-3
3.2.1 Process Equipment.....	3-3
3.2.2 Building Mechanical.....	3-5
3.2.3 Instrumentation & Control.....	3-5
3.2.4 Electrical.....	3-5
3.3 Treatment Process Train	3-5
3.3.1 Process Equipment.....	3-5
3.3.2 Instrumentation & Control.....	3-8
3.3.4 Electrical.....	3-8
3.4 Transfer Pump Station and Storage	3-9
3.4.1 Process Equipment.....	3-9
3.4.1.1 Transfer Pumps.....	3-9
3.4.1.2 Additional Clearwell Tank	3-10

3.4.2 Structural.....	3-12
3.4.3 Instrumentation & Control.....	3-12
3.4.4 Electrical.....	3-12
3.5 Finished Water Pump Station.....	3-13
3.5.1 Process Equipment.....	3-13
3.5.2 Building Mechanical.....	3-14
3.5.3 Instrumentation & Control.....	3-14
3.5.4 Electrical.....	3-14
3.6 Recycle Pump Station.....	3-15
3.6.1 Process Equipment.....	3-15
3.6.2 Instrumentation & Control.....	3-15
3.6.4 Electrical.....	3-15
3.7 Operations Building – Ground Level.....	3-15
3.7.1 Building Architectural & Structural.....	3-15
3.7.2 Instrumentation & Control.....	3-16
3.8 Operations Building – Basement Level.....	3-16
3.8.1 Building Mechanical.....	3-16
3.9 Operations Building – Chemical Facilities.....	3-17
3.9.1 Process Equipment.....	3-17
3.9.2 Building Mechanical.....	3-17
3.9.3 Instrumentation & Control.....	3-18
3.9.4 Electrical.....	3-18
3.10 Summary of Required Projects for Expansion.....	3-18
Section 4 Conclusions and Recommendations.....	4-1
4.1 Opinion of Probable Construction Cost.....	4-1
4.2 Recommendations.....	4-3

List of Figures

Figure 3-1 Raw Water Pump Station Combined Pump and System Curve Three Pump Operation.....	3-1
Figure 3-2 Raw Water Pump Station No. 2 Combined Pump and System Curve One Pump Operation.....	3-4
Figure 3-3 Tube Settler Installation Example (Image courtesy of Brentwood Industries, Inc.).....	3-7
Figure 3-4 Plate Settler Installation Example (Image courtesy of Meurer Research, Inc.).....	3-8
Figure 3-5 Transfer Pump Station Combined Pump and System Curve Two Pump Operation.....	3-9
Figure 3-6 Finished Water Pump Station Combined Pump and System Curve Three Pump Operation.....	3-13
Figure 4-1 Pee Dee Regional WTP Finished Water Demand Projection.....	4-4

List of Tables

Table 2-1 Existing Raw Water PS No. 1 VCT Pump Design Criteria	2-4
Table 2-2 Existing Raw Water PS No. 2 VCT Pump Design Criteria	2-7
Table 2-3 Existing Transfer Pump Design Criteria	2-12
Table 2-4 Existing Finished Water PS VCT Pump Design Criteria	2-13
Table 2-5 Existing Recycle Pump Station Pump Design Criteria	2-16
Table 2-6 Summary of Priority Projects	2-28
Table 3-1 Summary of Regulatory Requirements.....	3-6
Table 3-2 Design Criteria for New Clearwell Tank.....	3-10
Table 3-3 CT Requirements for Providing Disinfection in New Clearwell No. 2.....	3-11
Table 3-4 Clearwell Storage Remaining after CT Requirement and Filter Backwash	3-12
Table 3-5 Summary of Expansion Projects	3-18
Table 4-1 Summary of Condition Assessment Priority Projects.....	4-2
Table 4-2 Summary of Expansion Plan Projects	4-3

Appendices

Appendix A Design Life Table	
Appendix B Condition Assessment Spreadsheet	
Appendix C Condition Assessment Forms	
Appendix D Plant Expansion to 15 MGD and Review of State Regulatory Requirements Technical Memorandum	
Appendix E SC DHEC Operating Requirements and Filter Uprating Meeting Minutes	
Appendix F Selective Equipment Replacement Schedules	

Section 1

Introduction

1.1 Project Background

The City of Florence (the City) retained CDM Smith to evaluate and identify improvements to the Pee Dee Regional Water Treatment Plant (WTP) including replacement of equipment and systems that are at, or predicted to soon reach, the end of their intended service life and to expand the WTP permitted treatment capacity from 10.0 million gallons per day (MGD) up to 15.0 MGD permitted peak production capacity to the extent approvable by the State. The first phase of the study included a condition assessment of major equipment and systems at the WTP. The second phase of this study was an evaluation of facility replacement and/or expansion options to add up to 5 MGD to the facility's permitted treatment capacity. Expansion of the Pee Dee Regional WTP is proposed to be accomplished by up-rating the filters, as opposed to building new treatment process trains. In addition to the identified improvements needed, the State typically expects full-scale testing for up to a year with one train of the plant to demonstrate satisfactory performance at uprated flows. The assessment will guide the City in prioritizing and planning capital improvement projects and will include a condition assessment, recommendation of priority projects, and an opinion of cost for the priority projects.

1.2 Overview of Existing Facilities

The Pee Dee Regional WTP is a conventional treatment plant rated at 10.0 MGD with all filters in service at their current rated capacity. The plant was originally constructed in 2002. While the plant has undergone minor improvements to improve treatment performance and replace failing equipment, the plant is nearing 20 years old, and some equipment is at or near the end of its useful life. As of 2020, the plant is operated 16 hours per day (6:00 AM to midnight), 7 days per week.

Raw water is pumped from the Pee Dee River at the raw water intake and pump station approximately 3 miles from the WTP. Processes at the plant include reservoir storage and pumping, rapid mixing and flocculation, sedimentation, filtration, chlorine disinfection, storage, and finished water pumping. Numerous chemical feed and storage systems are required to support water production – ferric sulfate, polymer, sodium hypochlorite, sodium hydroxide, lime, and fluorosilicic acid. Additionally, copper sulfate is fed at the raw water reservoir as an algacide when needed. The systems and equipment necessary to feed potassium permanganate and aqua ammonia also exist on-site but have never been operated.

1.3 Organization of Report

This report is organized as follows:

- Section 1 – Introduction
- Section 2 – Condition Assessment

- Section 3 – Plant Expansion
- Section 4 – Conclusions and Recommendations

Section 2

Condition Assessment

CDM Smith conducted a condition assessment of the Pee Dee Regional WTP to identify the physical and operable condition and reliability of the equipment and facilities. This condition assessment is intended to document the physical condition, performance, operation and maintenance issues, and estimation of remaining service life of plant equipment and structures to provide information to prioritize rehabilitation or replacement needs.

This section provides an overview of the established procedures used for the assessments, reviews the observations and findings of the assessments, documents and summarizes the condition rating of the assets, provides prioritization of need based on the assessment, and descriptions of recommended improvements.

2.1 Methodology

The assessment consisted of non-destructive visual assessment methods, examination of maintenance records, and discussions with WTP operations and maintenance staff to determine the condition of the equipment, process, or system. The findings were documented and assigned both a level of priority and functional category.

2.1.1 Physical Facilities

The condition assessments categorize the facility into the following principal process areas:

- Raw Water Pump Station No. 1 (from Pee Dee River Intake)
- Raw Water Pump Station No. 2 and Reservoir
- Treatment Process Train
- Transfer Pump Station and Storage
- Finished Water Pump Station
- Recycle Pump Station
- Operations Building – Ground Level
- Operations Building – Basement Level
- Operations Building – Chemical Storage

2.1.2 Level of Priority

Levels of priority are used to categorize equipment and structure deficiencies within each process area. Priorities are ranked on a five-point scale, where “Class 1” indicates imminent failure and critical impact to plant operations and safety, while “Class 5” indicates that a correction should be

made but failure will not impact overall plant operations or safety. Descriptions of the levels of priority are presented below. Equipment and facilities with no noted deficiencies are not rated.

- Class 1 – A condition in which failure of the system, equipment or building components is imminent, and its failure would directly and significantly impact operations at the WTP, including treatment capacity, water quality, and safety
- Class 2 – A condition in which failure of the system, equipment or building component is imminent, and failure would result in loss of back-up capacity, or cause further damage, but not impact operations in terms of treatment capacity, water quality, or safety
- Class 3 – A condition of failure or imminent failure of the system, equipment or building component that will not impair operations or safety but may lead to deterioration that would increase repair costs
- Class 4 – An improvement that has not been made that would result in protecting the status quo with regard to water quality, water production quantity, or safety
- Class 5 – Any system, equipment, or building component that should be corrected or improved, and in which the failure does not impact water quality, water production quantity, or safety

2.1.3 Functional Category

The recommended improvement projects generated from the condition assessment were assigned a functional category as follows:

- O - Operational Improvements – Capital improvement projects that directly impact production or water quality
- N - Non-operational Improvements – Capital improvement projects that do not directly impact production or water quality
- M - Maintenance Improvements – Maintenance related improvements

2.1.4 General Information and Properties

In addition to the priority level and function category, CDM Smith observed and recorded other general information and properties about each asset as a part of the condition assessment. Data was taken from equipment nameplates, record drawings, construction submittals, and discussions with plant staff. Where applicable the following information was collected:

- Equipment Tag
- Environment (Indoors, Outdoors, Corrosive, etc.)
- Manufacturer, Model, and Serial Number
- Capacity and Speed
- Power, Amperage, and Voltage

- Approximate Age and Estimated Service Life Remaining
- Code Compliance

Estimated Service Life Remaining was based on the approximate age of the equipment, the typical industry estimation of service life (refer to Appendix A for standards used), and engineering judgement. Many items observed during the condition assessment, such as motors, variable frequency drives, air compressors, tanks, etc., are at or nearing the end of this estimated service life. Equipment may continue to function and operate as intended for many additional years, but items approaching, or already beyond, their estimated service life should be closely monitored and considered for potential replacement in the near future. This is especially important for process-critical equipment such as pumping and treatment train infrastructure.

Information gathered and presented regarding the code compliance of equipment and structures refers to current building and safety code standards. The Pee Dee Regional WTP was designed according to the code and design standards required at the time of its construction. In the intervening years between the plant's construction and this condition assessment, applicable codes may have been changed or updated. Making modifications to a structure or changing a piece of equipment may trigger the application of current code standards for a room or area that is currently considered to be code compliant.

2.2 Condition Observations

The following conditional assessment observations were made during the equipment inspection process and subsequent staff interviews. Refer to Appendix B for tabulated condition assessment observations; refer to Appendix C for individual condition assessment observation forms. Based on the condition assessment findings discussed below and input from the City, CDM Smith proposes several improvement projects for the City to consider as a part of their annual capital upgrades.

Assessments have been grouped by location and process area as described in Section 2.1.1. Assessments are further broken down by engineering discipline (process, electrical, etc.). At the end of each sub-section, a "Summary of Priority Projects" has been provided. The lists do not include all potential pursuable projects identified in the text, but rather a subset of priority projects. These lists were developed by CDM Smith in coordination with the City at a project workshop and in other subsequent communications.

2.2.1 Raw Water Pump Station No. 1

Raw Water Pump Station No. 1 is located adjacent to the Pee Dee River. The pump station is a circular cast-in place concrete structure consisting of three floors. The top floor of the pump station houses the pump motors, air compressors, and an electrical room. The intermediate floor of the pump station structure contains the individual discharge pipes and vertical air receiver tank for the compressed air system. The bottom floor contains the three intake raw water conveyance pipes and pre lube pump. The existing intake pipes and T-screens are located at varying river depths to provide mid and low-level suction locations in the river. The raw water pumps can direct flow to either the raw water reservoir or directly to the rapid mix basins.

2.2.1.1 Process Equipment

Intake Screens

Intake screens were not observable during the assessment since they are submerged. Plant staff noted that screens are inspected annually and that screen hardware has been recently replaced. The intake screens are therefore assumed to be in good condition.

Air Compressors and Receiver Tank

The air compression system was not running during the assessment. Visual observation of both the compressors and tank indicate they are in good condition. Plant staff stated that the system performed satisfactorily. The air compression system is approaching 20 years in service; typical design life for air compressors is 25 years. The compressors should continue to be monitored for signs of wear and aging that would warrant replacement.

Raw Water Pumps and Pipes

The pump station intake includes two 30-inch steel pipes. Each 30-inch steel pipe connects to a 30-inch tee which then connects to two intake T-screens. An existing 36-inch steel pipe was installed to provide a third future raw water conveyance pipe. This 36-inch pipe connects to a 36-inch tee, which then reduces to two 30-inch pipes with blind flanges for future installation of four additional T-screens.

The pump station contains three existing Model 22SNL Ingersoll-Dresser (IDP) (now manufactured by Flowserve) multi-stage centrifugal vertical turbine can (VTC) pumps which receive flow via individual 30-inch suction pipes connected to the common suction header and pump can. The existing VTC pump design criteria is described below in **Table 2-1**.

Table 2-1 Existing Raw Water PS No. 1 VCT Pump Design Criteria

Description	Value
Quantity of Installed Pumps	3 (2 duty, 1 stand-by)
Pump Type	Centrifugal Vertical Turbine Can Pump
Manufacturer/Model	Ingersoll-Dresser Pumps (IDP)/22SNL
Impeller Type	Semi-Open
Stage Count	3
Pump Rated Flow (gpm), ea.	4,000
Pump Rated Head (ft)	146
Motor Type	Vertical TEFC – Hollow Shaft
Motor Horsepower	200
Motor Phase/Hertz/ Voltage	3/60/460
Motor Speed (rpm)	900

The pump station includes space for a fourth future pump to be installed. The can for the fourth pump was previously installed and blind flanges on the common suction and discharge headers are present for future individual suction and discharge piping connections.

All pumps appeared to be in good working condition. WTP staff did not relay any performance issues. All pumps are approaching 20 years in-service, however, Raw Water Pumps No. 1 and 2

have been rehabilitated within the last ten years. Therefore, the rehabilitation of Raw Water Pump No. 3 is recommended as part of an improvements project.

Pre-Lube Pump

The pre-lube pump is not currently used at the pump station. Staff stated that the pump would not shut off after initiation and was taken offline. The working condition of the pump is therefore unknown. Due to the importance of a pre-lube system for preventing wear in the Raw Water Pumps, it is recommended that the pre-lube pump be replaced and/or its control logic investigated. In its current location on the bottom floor, it is in danger of being flooded. As the cost of the pump itself is insignificant to the cost of relocation, a shelf-spares pump should be provided for redundancy.

Sump Pump

Sump pump was not observed in operation but appeared to be in fair or good condition. The pump and sump are equipped with float switches for automatic operation. Similar to the pre-lube pump, the pump motor is in danger of flooding in its current location and purchase of a shelf-spares is recommended.

2.2.1.2 Electrical Equipment

The electrical equipment at the Raw Water Pump Station No. 1 includes three single-phase utility transformers mounted on a pole-platform system, an outdoor generator, an automatic transfer switch, a 480V 1600A MCC, and three Raw Water Pump Station variable frequency drives (VFD). The utility transformers and generators are located outdoors, all other electrical equipment is located in the electrical room, B-103.

The electrical equipment visual inspection did not reveal any significant issues. However, given that the VFDs are near the end of their expected useable service life, it is a recommended improvements project to replace the existing pump VFDs. The generator enclosure was not accessible, though the exterior showed some buildup of lichen and moss on the air vents; these should be periodically inspected and kept clear to allow adequate air flow.

2.2.1.3 Building Architectural & Structural

Architectural

The building includes an elevated Pump Room and Electrical Room over a concrete structure, connected by a stairwell. The upper level is a split-face CMU veneer cavity wall construction with an insulated low-slope membrane roofing system with low parapet and aluminum coping.

Overall, the building exhibits conditions expected for a building approaching twenty years of use. The exterior envelope, including veneer and louvers display discoloration and staining. There is cracking and adhesion failure noted in control joints. It was observed that the exterior access stair railing is not compliant with current stair railing code requirements. The roof could not be inspected due to lack of access; however, given the age of the roofing system, it is recommended that the roofing system be replaced as a part of the improvements projects.

The interior of the upper level exhibits corrosion and coating failure at the pump pads and some slight water intrusion evidence at the skylights and monorail door. The lower level and stair

exhibit extensive water damage and ponding with visible algae and mold, as well as efflorescence at the CMU walls. The water damage also resulted in extreme corrosion of the steel doors and frames and associated door hardware.

Structural

The previously discussed water damage has resulted in deterioration of the base of the CMU walls, which surround the stairs. Unattached grating supports and loose toeboard was observed at the second stair landing from top. Random shrinkage cracks were also observed on the slab and wall surfaces. Some of the cracks in the wall surface exhibit leakage. Light corrosion was observed in the roof joists

2.2.1.4 Building Mechanical

HVAC

The HVAC equipment at the Raw Water Pump Station No. 1 includes roof mounted exhaust fans and supply fan, electric unit heaters, and split-system air conditioning units. Outside air for the upper level is provided by intake air louvers with motor operated dampers.

The split-system air conditioning units were recently replaced and in good condition. The roof mounted exhaust fans could not be observed (no roof access). EF-26 did not appear to be running, and the fan could not be activated via thermostat control. Per record drawings, EF-27/SF-3 were designed to run continuously. They were not observed to be running even though they were on at the MCC. It was observed that many of the electric unit heaters were off at their local disconnects. It was also observed that the motor operated dampers associated with the intake louver could use maintenance/adjustment. Given the age of the equipment, the replacement of the existing electric unit heaters, exhaust fans and supply fan in Raw Water Pump Station No. 1 is proposed as an improvements project for future reliability.

Plumbing

The plumbing equipment at the Raw Water Pump Station No. 1 includes drain waste and vent piping, washdown hose stations, wall hydrants, and a sump pump.

The plumbing visual inspection did not reveal any significant issues.

2.2.1.5 Instrumentation & Control

PLC-1 is located in the electrical room at the pump station. The original OIT has been replaced with a desktop monitor that is placed on the top of the PLC enclosure. The original OIT cutout on the door to the PLC enclosure is open. While the electrical room is a heated and cooled space, dust and potentially rodents could enter to the control panel and cause intermittent wiring issues. Replacement of the PLC-1 OIT is a recommended improvements project.

2.2.1.6 Summary of Priority Projects

The following is a summary of projects identified with their priority and category:

1. Rehabilitate Raw Water Pump No. 3 and pre-lube pump (Class = 2, Category = O)
2. Replace PLC-1 OIT (Class = 3, Category = N)
3. Replace VFDs (Class = 2, Category = O)

4. Replace supply fan, exhaust fans, and unit heaters (Class = 3, Category = N)
5. Replace roof (Class = 3, Category = N)

2.2.2 Raw Water Pump Station No. 2 and Reservoir

Raw Water Pump Station No. 2 and the Raw Water Reservoir are located on the southern portion of the Pee Dee Regional Water Treatment Plant site. The pumps are located outdoors on a concrete slab between a storage canopy and electrical building. The Reservoir consists of an HDPE liner over compacted fill. It is surrounded by a 20-foot berm, which also acts as an access road.

2.2.2.1 Process Equipment

Raw Water Pumps

The pump station is comprised of two existing Model 24VTSH Fairbanks Morse (now manufactured by Fairbanks Nijhuis) single-stage centrifugal vertical turbine can (VTC) pumps which receive flow from the adjacent raw water reservoir via a 48-inch ductile iron pipe connected to the reservoir outlet structure. The existing VTC pump design criteria is described below in **Table 2-2**.

Table 2-2 Existing Raw Water PS No. 2 VCT Pump Design Criteria

Description	Value
Quantity of Installed Pumps	2 (1 duty, 1 stand-by)
Pump Type	Centrifugal Vertical Turbine Can Pump
Manufacturer/Model	Fairbanks Morse/24VTSH
Impeller Type	Enclosed
Stage Count	1
Pump Rated Flow, ea. (gpm)	11,000
Pump Rated Head (ft)	30
Motor Type	Vertical TEFC – Hollow Shaft
Motor Horsepower	125
Motor Phase/Hertz/ Voltage	3/60/460
Motor Speed (rpm)	591

Each pump has individual 24-inch discharge piping with check and butterfly valves, which then connect to a below grade 36-inch discharge header which conveys flow to the treatment modules at a connection point upstream of the existing venturi flow meter. The station includes space for a third future pump. During the original construction project, the pump can and below grade suction and discharge piping were previously installed with blind flanges for future connections.

Both pumps are in fair condition with no performance issues noted from staff. Grating over the access port to the shaft coupling is missing in several spots and vegetation was observed to be growing near and around the shaft. The growth did not appear to impair pump function, but it should be cleared away and the grating over the openings replaced. The pumps are approaching 20-years of service and have not been rehabilitated. It is a recommended improvements project that the pumps be serviced and rehabilitated to ensure future reliability.

2.2.2.2 Electrical Equipment

The electrical equipment at the Raw Water Pump Station No. 2 includes two 800A MCCs, one 480-208/120V transformer, one 208/120V panelboard, and two reservoir pump VFDs. Additionally, there is space reserved for an additional future reservoir pump VFD.

The electrical equipment visual inspection did not reveal any significant issues. However, given that the VFDs are near the end of their expected useable service life, it is a recommended improvements project to replace the existing pump VFDs.

2.2.2.3 Building Architectural & Structural

Architectural

The building is a single-story Electrical Building with split-face CMU veneer cavity wall construction and an insulated low-slope membrane roofing system with low parapet and aluminum coping. Adjacent to the building is a pre-engineered metal canopy for equipment storage.

Overall, the building exhibits conditions expected for a building approaching twenty years of use. The exterior envelope, including veneer, displays discoloration and staining. There is cracking and adhesion failure noted in control joints. There is damage to the aluminum coping along one section of the roof edge. The canopy exhibits some discoloration and chalking of steel coating, with some minor evidence of rust. The roof could not be inspected due to lack of access; however, given the observed damage to the coping and the age of the roofing system, it is recommended that the roofing system be replaced as a part of the improvements projects summarized below in Section 2.2.2.6.

The interior of the Electrical Room displays stained ceiling panels, indicating roof leaks along the wall and roof joint. There is extensive staining of the floor indicating past water infiltration issues, potentially from the AHU. The double personnel door needs to be adjusted to remove the gaps between the panels. Previous repainting of the interior appears to be incompatible with the control joints and cracking and peeling of the paint is visible.

Structural

The storage canopy was observed to have coating loss. The anchor bolts were also observed to have corrosion and the grout under the canopy column baseplates was deteriorated. Cracks were observed in the slab surrounding the pumps and, in the pump, can concrete. The joint sealant in the slab surfaces was also observed to be deteriorating. Stair-step cracking was observed in the CMU walls of the electrical building, above the south-facing door. Evidence of previous roof leakage was also observed. Recoating of the existing canopy and anchor bolts is recommended as an improvement project.

2.2.2.4 Building Mechanical

HVAC

The HVAC equipment at the Raw Water Pump Station No. 2 includes split-system air conditioning units.

The air conditioning units are in fair condition, but near the end of their useful lives. AHU-2's condensate line was leaking on the floor of the electrical room. The overflow was draining through the corroded overflow box, this indicates the primary condensate drain is clogged. Therefore, it is recommended that the air handling units in Raw Water Pump Station No. 2 be replaced to improve future pump station HVAC system reliability.

2.2.2.5 Instrumentation & Control

PLC-6 is located in the electrical building and is in great condition. Field instrumentation at the lagoon, the raw water pumps and the recycle pump station are in good condition. Field devices have surge protection that are located outdoors and sunshields.

2.2.2.6 Summary of Priority Projects

The following is a summary of projects identified with their priority and category:

1. Rehabilitate both Raw Water Pumps (Class = 2, Category = O)
2. Replace VFDs (Class = 2, Category = O)
3. Replace HVAC equipment (Class = 3, Category = N)
4. Roof replacement (Class = 3, Category = N)
5. Canopy rehabilitation (Class = 3, Category = M)

2.2.3 Treatment Process Train

The WTP's main treatment process train is adjacent to the Operations Building. The plant follows a conventional treatment scheme with rapid mix, flocculation, sedimentation, and filtration. Processes are connected by a network of open channels.

2.2.3.1 Process Equipment

Rapid Mixers

All four rapid mixers are in good working condition. The mixer shafts and impellers were not observable during the assessment, but staff stated that they had not encountered any problems with them.

Flocculators

Similar to the rapid mixers, the flocculators are in good condition but shafts and impellers were not observable. They are assumed to be in good condition.

Sludge Collectors

Each sedimentation basin contains a chain-and-flight and cross-collector system for sludge removal. The equipment in all three basins is operable but nearing the end of its useful life. Discussions with plant staff suggested that there is a desire to replace the existing chain-and-flight sludge collection system in entirety for future reliability, making it a recommended improvements project.

Filters

All six filters are in good condition. Filter media (GAC and sand) has been replaced within the last 2-4 years. The filter backwash troughs and associated hardware show signs of aging. Troughs are

visibly bowed, and staff noted that many are loose, causing them to slide during backwash. The troughs should be replaced to ensure continued performance of the filter backwash system.

Process Valves

Mud, gate, and butterfly valves are used throughout the treatment train to direct and isolate flows.

The 24-in influent water mud valve on the north end of the treatment area cannot be closed. The shaft/stem system for the 12-in mud valve in Flocculation Basin 2C is broken and should be replaced. Mud valves throughout the rapid mix and flocculation basins are severely corroded and inoperable. All mud valves should be replaced as part of an improvements project and alternate construction materials shall be investigated for highly corrosive environments.

Staff noted that most slide gates functioned well, but that when shutting down portions of the train the pressure differential often caused them to pop out of place. This is a safety hazard for staff when isolating portions of the process train. Replacement of slide gates and seating is a recommended improvements project, and alternate gate configuration or types should be investigated to prevent this problem from occurring moving forward.

Based on discussions with plant staff during the Condition Assessment Workshop, it was determined that selective replacement of slide gates and mud valves should be considered. Refer to **Appendix F** for a gate and valve replacement schedule.

2.2.3.2 Electrical Equipment

Power is supplied to the treatment process train through a combination of electrical equipment, including switchgear, MCCs, and panelboards. Some equipment, such as the flocculators and rapid mixers are fed from MCC-mounted VFDs that may be approaching their end of service life. Refer to Appendix B - Condition Assessment Spreadsheet for list of electrical equipment and condition rating.

2.2.3.3 Building Architectural & Structural

Structural

The treatment process train was observed from the top slab only, except for Sedimentation Basin No. 1 which was drained and allowed for a limited interior observation of the concrete. Based on the observations further discussed below, it is a recommended improvements project to recoat the concrete in the rapid mix, flocculation, and sedimentation basins.

Rapid Mix

Spalled concrete was observed around the gates exiting the rapid mix chambers and channels. The expansion joint sealant was also observed to be deteriorated. The ladders to the filter area are recommended to have self-closing gates for fall protection.

Flocculation

Random shrinkage cracks were observed in the slabs covering the flocculation tanks. Pattern cracks having the appearance to follow the reinforcement layout and spacing were also observed in these slabs. Cracking along the expansion joint was observed, and the sealant was

deteriorating. The railing around the slab openings adjacent to the rapid mix area, which steps up, was observed to be too low in accordance with current code requirements.

Sedimentation Basins

Shrinkage cracks and pattern cracking were observed along the elevated walkway surfaces. In some locations, efflorescence was emanating up through the pattern cracks on the walkway surfaces. It is likely that the undersides of the slab surfaces are coated and not allowing water to migrate through the concrete. The toeboards were observed to be wavy along the guardrail. It is likely that insufficient expansion joints were provided in the toeboard.

Sedimentation Basin No. 1 was entered at the southeast corner and observations of the wall surfaces were limited to that area. Deterioration of the surface paste of the concrete surface was observed. The approximate surface loss is estimated to be 1/8-inch. The concrete surface beneath the deteriorated surface were hard when struck with a hammer.

Filters

Shrinkage cracks were observed, and all joint sealant was observed to be deteriorated. Cracks in the concrete curbs continue down into the filters and some spalling appears to be taking place. The coated surfaces inside the filters were observed above the water line to be deteriorated and have cracks propagated through the coating from the concrete. The condition below the water line could not be observed but likely in worse condition than above the water line.

2.2.3.4 Instrumentation & Control

The instrumentation on the sedimentation basin influent channels consists of an ultrasonic level sensor and transmitter with a high level float. The ultrasonic level transmitter is located outdoors under a sunshield with 120 VAC and analog surge protection.

Each filter has an ultrasonic level sensor and transmitter along with a capacitance probe. The ultrasonic level transmitter is located outdoors under a sunshield with 120 VAC and analog surge protection.

All field devices are operational, however, several of the ultrasonic level transmitters appear to be original and should be replaced when no longer operational.

2.2.3.5 Summary of Priority Projects

The following is a summary of projects identified with their priority and category:

1. Replace sedimentation basin chain and flight system (Class = 2, Category = O).
2. Replace mud valves and isolation slide gate valves in the rapid mix, flocculation, and sedimentation basins (Class = 3, Category = O).
3. Re-coating of rapid mix, flocculation, and sedimentation basins (Class = 3, Category = M).

2.2.4 Transfer Pump Station and Ground Storage Tank

The Transfer Pump Station is located on the northern end of the filter gallery on the basement level. The pumps pull from the adjacent enclosed wetwell and pump settled water to the clearwell. Clearwell No. 1 is a 2-million-gallon pre-stressed concrete tank located on the western

edge of the plant site. The clearwell is used for finished water storage and disinfection. It also serves as the backwash water source for the filters.

2.2.4.1 Process Equipment

Transfer Pumps

The pump station is comprised of three Model 12MFC21 Ingersoll-Dresser Pump (IDP) (now manufactured by Flowserve) dry-pit vertical centrifugal solids handling pumps which receive flow from an adjacent wetwell via individual ductile iron suction piping. The existing transfer pump design criteria is described below in **Table 2-3**.

Table 2-3 Existing Transfer Pump Design Criteria

Description	Value
Quantity of Installed Pumps	3 (2 duty, 1 stand-by)
Pump Type	Dry Pit Vertical Centrifugal Solids Handling
Manufacturer/Model	Ingersoll-Dresser Pump (IDP)/12MFC21
Impeller Type	Enclosed
Stage Count	1
Pump Rated Flow, ea. (gpm)	5,250
Pump Rated Head (ft)	57
Motor Type	Vertical TEFC – Hollow Shaft
Motor Horsepower	100
Motor Phase/Hertz/ Voltage	3/60/460
Motor Speed (rpm)	900

Each pump has individual 12-inch discharge piping with check and butterfly valves, which then connect to a common 36-inch discharge header which conveys flow to the clearwell. The station does not include space for a future fourth pump, but the wetwell and initial portion of the suction piping were designed to allow for replacement of the existing pumps with larger higher flow output pumps.

One of the pumps was out-of-service at the time of assessment due to an unknown issue with the bearings or motor. The other two pumps are in good working condition. None of the pumps have ever been rehabilitated, and all are approaching 20 years of service. It is recommended that all pumps are serviced and rehabilitated. There is also very limited means for plant staff to feasibly replace and/or bring in new pump components. Improvements to the facilitate pump removal and replacement in full is desired by plant staff.

2.2.4.2 Electrical Equipment

The electrical equipment in the Transfer Pump Station includes three transfer pump VFDs located in Electrical Room No. 1.

The electrical equipment visual inspection did not reveal any significant issues. However, given that the VFDs are near the end of their expected useable service life, it is a recommended improvements project to replace the existing pump VFDs.

2.2.4.3 Instrumentation & Control

The ultrasonic level sensor and transmitter as well as the visual level indicator on Clearwell No. 1 are in good condition and functional.

2.2.4.4 Summary of Priority Projects

The following is a summary of projects identified with their priority and category:

1. Rehabilitate all Transfer Pumps (Class = 2, Category = 0)
2. Replace Transfer Pump VFDs (Class = 2, Category = 0)

2.2.5 Finished Water Pump Station

The Finished Water Pump Station is located to the west of the Operations Building and Treatment Process Train in an enclosed building. The building contains a pump room and an electrical room.

2.2.5.1 Process Equipment

Finished Water Pumps

The station contains three existing Model 23EKM Ingersoll-Dresser (IDP) (now manufactured by Flowserve) multi-stage centrifugal vertical turbine can (VTC) pumps which receive flow from the clearwell via individual below grade 24-inch suction pipes connected to the common 36-inch suction header and pump can. The existing VTC pump design criteria is described below in **Table 2-4**.

Table 2-4 Existing Finished Water PS VCT Pump Design Criteria

Description	Value
Quantity of Installed Pumps	3 (2 duty, 1 stand-by)
Pump Type	Centrifugal Vertical Turbine Can Pump
Manufacturer/Model	Ingersoll-Dresser Pumps (IDP)/23EKM
Impeller Type	Enclosed
Stage Count	5
Pump Rated Flow (gpm)	3,500
Pump Rated Head (ft)	225
Motor Type	Vertical TEFC – Hollow Shaft
Motor Horsepower	300
Motor Phase/Hertz/ Voltage	3/60/460
Motor Speed (rpm)	900

Flow is conveyed through 16-inch individual discharge pipes which connect to a common 36-inch discharge header which then conveys flow to the distribution system.

The station includes space for a fourth future pump to be installed. The can for the fourth pump was previously installed and blind flanges on the suction and discharge piping are present for future piping connections.

All three pumps are in good working condition. As the pumps are approaching 20 years in-service, they should be rehabilitated to ensure continued performance, as further summarized below as an improvements project.

Sample Pump

The Finished Water Sample Pump is in good condition.

2.2.5.2 Electrical Equipment

The electrical equipment at the Finished Water Pump Station includes two 480V 1200A MCCs, one 480-208/120V transformer, three 208/120V panelboards (one rated at 480/277V), and three Finished Water Pump VFDs.

One section of Finished Water Pump #1 VFD has been recently replaced. The Finished Water Pump #3 VFD was found with doors open, presumably for servicing. Given that the original VFDs were installed at the same time, the fact that one has already experienced a failure could indicate the others may need to be replaced in the near future. It is a recommended improvements project to replace the existing pump VFDs.

The transient voltage surge suppressors (TVSS) installed at MCC-3A and MCC-3B indicate “reduced protection”. These devices protect the equipment from voltage surges – such as might be caused by lightning – and should be inspected and repaired.

2.2.5.3 Building Architectural & Structural

Architectural

The building is a single-story building with Electrical and Pump Rooms. It is split-face CMU veneer cavity wall construction with an insulated low-slope membrane roofing system with low parapet and aluminum coping. Roof access is provided by interior access ladder in the Pump Room.

Overall, the building exhibits conditions expected for a building approaching twenty years of use. The exterior envelope, including veneer, displays discoloration and staining. There is cracking and adhesion failure noted in control joints. Discoloration of the aluminum louvers is present along with visible insulation from the blades. The roof is a ballasted membrane roof, so inspection of the membrane surface at all locations was not possible. Some accumulation of sediment was observed, indicated slight ponding. The membrane along the parapet wall exhibits bubbling and delamination from the wall surface. It is recommended that the roof system be replaced in its entirety as part of the recommended improvements projects.

The interior of the Pump Room exhibits some discoloration and staining of the flooring around the floor drains. Interior painting throughout the building is in good condition, with some slight accumulation of dirt and dust present. However, previous repainting of the interior appears to be incompatible with the control joints and cracking and peeling of the paint is visible. Several doors need adjustment to closers; it was observed that doors don't fully close unassisted. There is some slight evidence of staining around the ceiling line, indicating existence of water infiltration along the roof and wall joint.

Structural

The split-face CMU was observed to be cracked in one location, under the southeast louver. Random shrinkage and pattern cracking was observed in the concrete floor slab surface. Water leakage from pump drains was also observed to enter the isolation joints around the concrete pump pads.

2.2.5.4 Building Mechanical

HVAC

The HVAC equipment at the Finished Water Pump Station includes roof mounted exhaust fans, electric unit heaters, and split-system air conditioning units. Outside air for the pump room is provided by intake air louvers with motor operated dampers.

The split-system air conditioning units were recently replaced and are in good condition. Roof mounted exhaust fan EF-1 was not observed to be operating. Roof mounted exhaust fan EF-2 was operating, but damper associated with the fan was not open. However, due to the age of the existing electric unit heaters and exhaust fans, a recommended improvements project would include the replacement of these units to ensure future Finished Water Pump Station HVAC system reliability.

Plumbing

The plumbing equipment at the Finished Water Pump Station includes drain waste and vent piping, washdown hose stations, wall hydrants, and storm water system.

The plumbing visual inspection did not reveal any significant issues.

2.2.5.5 Instrumentation & Control

PLC-4 is located in the electrical room within the Finished Water Pump Station building. The OIT located on the face of the PLC enclosure is not illuminating properly and is very difficult to read. It is recommended that the OIT on this unit be replaced as part of the recommended improvements projects.

The field instrumentation in the pump station (pH probes, chlorine analyzers, turbidimeters) are in good working condition.

The HACH 1720E turbidimeters are considered by HACH to be obsolete. While parts may still be readily available for several years, consideration should be made to start migrating to HACH's newer laser turbidimeter, the TU5. It is recommended that the existing turbidimeters and controllers be replaced as part of the improvements' projects.

HACH CL17 chlorine analyzers are not considered obsolete and thus are not required to be upgraded to newer technology at this time.

2.2.5.6 Summary of Priority Projects

The following is a summary of projects identified with their priority and category:

1. Rehabilitate all Finished Water Pumps (Class = 2, Category = 0)
2. Replace VFDs (Class = 4, Category = 0)

3. Roof replacement (Class = 1, Category = N)
4. HVAC replacement (Class = 3, Category = N)
5. Replace PLC-4 OIT (Class = 3, Category = N)
6. Replacement of turbidimeters (Class = 3, Category = 0)

2.2.6 Recycle Pump Station

The Recycle Pump Station is located to the north of the plant water reclamation lagoons. Pumps are located outdoors in a pre-cast concrete manhole. The pump station was originally configured to pump supernatant from the lagoons to the head of the plant. However, treatment residuals are now pumped to a gravity sewer that flows to the Florence Regional Wastewater Management Facility, instead.

2.2.6.1 Process Equipment

Recycle Pumps

The pump station contains three existing submersible pumps which receive flow from the water reclamation lagoons via a below-grade 12-inch pipe which connects the wetwell to the reclamation lagoons. Flow is conveyed through individual 8-inch discharge pipes which connect to a common 12-inch discharge header. The existing pump design criteria is described below in **Table 2-5**. The pump station includes space for a fourth future pump to be installed. The discharge piping for the fourth pump was previously installed.

Table 2-5 Existing Recycle Pump Station Pump Design Criteria

Description	Value
Quantity of Installed Pumps	3 (2 duty, 1 stand-by)
Pump Type	Submersible Non-Clog
Manufacturer/Model	Ingersoll-Dresser Pumps (IDP)/4MSX9A
Stage Count	1
Pump Rated Flow (gpm), ea.	400
Pump Rated Head (ft)	36
Motor Horsepower	7.5
Motor Phase/Hertz/ Voltage	3/60/460
Motor Speed (rpm)	1760

All three pumps are in good working condition with no issues noted by WTP staff. Pumps are approaching 20 years in service and are nearing the end of their anticipated useful service life

2.2.6.2 Structural

Minor surface loss of the precast concrete surfaces was observed in the recycle pump station.

2.2.6.3 Instrumentation & Control

The pump station control panel is located adjacent to the recycle flow meter vault. The control panel consists of selector switches, pilot lights and run time panel mounted meters. Within the recycle vault is the magnetic flow meter and the HACH Surface Scatter 7 turbidimeter.

The wet well level transmitter, the magnetic flow meter transmitter, and turbidimeter display are located under sunshield adjacent to the recycle vault. All instruments have 120 VAC and analog surge protection and are in good condition.

2.2.6.4 Summary of Priority Projects

No priority projects were identified for this area.

2.2.7 Operations Building – Ground Level

The Operations Building contains all administrative offices, the plant laboratory, operations center, bathrooms/locker rooms, conference rooms, kitchen, and staff break areas. It is the base of operations for staff on-site. The Filter Gallery is also located on the ground level of the Operations Building. It overlooks the filters and treatment train and houses the filter consoles.

2.2.7.1 Electrical Equipment

The electrical equipment associated with the Operations Building – including the general process and chemical areas – is primarily located in three electrical rooms and the generator room. Electrical Room No. 1, located west of the Chemical Storage portion of the Operations Building, includes the 480V main switchgear, the 480V MCC-1A and MCC-1B, one 480V power panel, four 208/120V power panels, and the switchgear batteries. The generator room is located adjacent to Electrical Room No. 1 and includes the 480V generator; most generator controls of electrical concern are located in the 480V main switchgear. Electrical Room No. 2 includes one 480V power panel, three 208/120V power panels, and one 480-208/120V transformer. The UPS room adjacent to the Control Room includes one 208/120V panelboard. The control room includes a fire alarm control panel and security alarm panel.

The WTP staff noted issues with generator/utility cycling during power outages that are initiated from the utility electrical system and result in transient voltages overloading some sensitive electronics. The primary source of these transients appears to be due to the return-to-utility settings of the system. This system appears to not have a significant delay between when the utility first reaches acceptable power quality measurements; as electrical utilities are dynamic systems; the power quality may take some time to stabilize. Without a requirement that the utility power quality be acceptable for a given amount of time (generally 5 minutes), the generator and utility may cycle on-and-off as the power quality reaches required thresholds. It is recommended that the generator controls be investigated and modified such that the utility is required to stay within acceptable power quality limits for a period of time before switching from the generator. As part of this recommended improvement project, the contractor should also check other control wiring, such as the mimic panel open/close indicators which do not appear to be functioning correctly.

The 480V switchgear batteries were found to be well below the recommended level of liquid shown on the individual cells. It is recommended that these cells be refilled to the appropriate level per the manufacturer's recommendations and be tested to confirm adequate performance.

The 480V MCCs demonstrate malfunctioning electrical demand metering as well as minor maintenance issues such as missing bolts and broken seals.

The electrical equipment in the Filter Gallery includes two 480V panelboards, one 480-208/120V transformer, and three 208/120V panelboards.

The electrical equipment visual inspection did not reveal any significant issues.

2.2.7.2 Building Architectural & Structural

Architectural

The building is single-story, comprised of split-face CMU veneer cavity wall construction with an insulated low-slope ballasted membrane roofing system with low parapet and aluminum coping. The overall building envelope contains the Administration and Operations areas, Education Center, Chemical Facilities, electrical and generator rooms, and below-grade Pipe Gallery, Transfer Pump Station, and wetwell. This section specifically addressed the architectural components of the building envelope for the entire structure and interior of the Administration, Operations and Education areas. Refer to subsequent sections for interior evaluations of the Chemical Facilities, Filter Gallery and Pipe Gallery areas.

Overall, the building exhibits conditions expected for a building approaching twenty years of use. The exterior envelope, including veneer, displays discoloration and staining. There is cracking and adhesion failure noted in control joints. Discoloration of the aluminum louvers is present and some staining and rust present at windows. Perimeter sealants for openings throughout exhibit cracking and shrinkage.

The roof is a ballasted membrane roof, so inspection of the membrane surface at all locations was not possible. Some accumulation of sediment was observed, indicated slight ponding. The membrane along the parapet wall exhibits bubbling and delamination from the wall surface. Some accumulation of trash and debris was observed. It is a recommended improvements project to replace the roof system in its entirety. Roof perimeter fall protection will need to be added for current code compliance at locations where serviceable equipment is within 10 feet of the roof edge. The roof access is from the mechanical mezzanine near the Maintenance Shop. The roof access ladder extension pole is not functioning, and the ladder should be replaced in its entirety.

It was observed that there is no permanent mezzanine access installed. A moveable access stair is present for use, but safety concerns are present, as it could be moved inadvertently while some one was on the roof or mezzanine, or if left in place could block egress from the Operations or Filter Gallery doors. It is a recommended improvements project to install a permanent ladder and landing with fall protection at the mezzanine access door.

The interior of the Administration, Education and Operations areas are in generally good condition. Water damaged and stained ceiling tiles are present in many locations, resulting from known roof leaks. Extensive water damage to the interior windowsill finish was observed in the Education area. The toilet room and locker room tile floors exhibit minor cracking and movement when walked on, which indicates some separation from the underlayment. The general condition of interior painting throughout is good, with only minor scuff marks and dirt present.

Laboratory casework exhibits extensive rust and discoloration from chemicals. It's recommended that the metal lab casework be replaced. Sample sinks were noted to be main source of extensive water splashing and accumulation. It is recommended to replace the sample sink with a

redesigned trough to minimize splashing. Multiple sinks have known plumbing issues, but the sinks are also damaged – including cracking and discoloration. The seamless flooring throughout is non-slip but is difficult to keep clean due to textured surfaced, as a result staining and discoloration was noted. Conversations with lab technician noted that there are concerns with equipment redundancy and storage. Per the above observations and discussions with plant staff, a main lab and BAC lab rehabilitation is proposed as part of the improvements' projects.

The maintenance shop space was observed to serve more as small parts storage, there was not extensive evidence of major repairs or equipment servicing being completed within the space. Discussion with plant staff indicated additional maintenance space configured for larger work areas and tool usage is desired.

The Filter Gallery serves as a connection between the Administration, Education and Chemical Facilities areas of the building.

In general, the interior finishes are in good shape. Flooring has been replaced, and there is some slight evidence of prior water infiltration and damage at the base of the wood doors along the corridor. Perimeter sealant of exterior openings is cracking and exhibits shrinkage. Door closers for exterior doors require slight adjustment to allow for them to fully close unassisted. A few damaged ceiling tiles were observed.

Structural

In the Pipe Gallery, actively leaking cracks were observed in the wall surfaces and some leakage around the expansion joint. The floor slab surfaces were observed to have random shrinkage cracks. Minor loss of coating on the west wall was also observed.

It was observed that the equipment mezzanine is being used for storage. The live load rating of this area is 100 psf and suitable for storage in accordance with building code requirements.

2.2.7.3 Building Mechanical

HVAC

The HVAC equipment at the Administration, Laboratory, and Operations Area includes split-system air conditioning systems, a rooftop air conditioning system, exhaust fans, supply fans, fin tube radiators, duct heaters, hot water unit heaters, and heating hot water loop. The filter gallery is served by the operations/administration area HVAC system.

The major HVAC equipment has been replaced recently for the education center, lab, and main operations portion of the building. The boiler is near the end of its useful life as indicated by plant staff and the boiler inspector. Additionally, the fume hood ventilation system should be verified to be functioning properly per ANSI/AIHA/ASSE Z9.5 and ANSI/ASHRAE 110. If the fume hood is not able to pass applicable tests with the current fan configuration, a lab exhaust fan should be provided in lieu of the existing roof mounted exhaust fan.

Selective replacement of HVAC equipment throughout the Operations Building is recommended. Refer to **Appendix F** for an HVAC replacement schedule. Equipment selection was based on condition and/or remaining useful service life.

Plumbing

The plumbing equipment at the Administration, Laboratory, and Operations Area includes drainage waste and vent piping, water closets, urinal, lavatories, water cooler, lab sinks, kitchen sinks, emergency fixtures, water heaters, showers, domestic hot and cold water, and stormwater systems.

It is recommended that flow sensors/alarms are installed on emergency fixtures. The gas water heaters GWH-1 & GWH-2 were observed to be in poor condition and near the end of their useful lives. The balance of the plumbing inspection did not reveal any significant issues.

2.2.7.4 Instrumentation & Control

The Operator Workstation in the control room consists of the original multiple screen workstation that is still used daily by operations. Operations stated that the number and size of the monitors is acceptable and the workstation itself comfortable.

The SCADA system hardware consists of a variety of components located in the UPS room adjacent to the Control Room. There is a 19-inch rack on the floor with three Dell PowerEdge 320 servers, with other 19-inch rack Ethernet switches mounted to the wall of the room, media (fiber to copper) converters on the walls and floor, wireless components (dial up modem – Pee Dee River Pump Station) and Cisco 810 routers, cellular telemetry system (distribution) mounted to the wall. While functional, troubleshooting the entire system would be challenging. It is a recommended improvements project to organize and appropriately label the existing instrumentation hardware in the UPS room.

The plant programmable logic controllers are all the Siemens SIMATIC S7-300 CPU with 128KB Memory, Siemens OSM TP62 10/100 Ethernet Switches connected in a ring configuration with fiber optic cables. Each PLC has two hot swappable PLCs, modular Input/output racks, analog surge suppression modules, and redundant power supplies. It appears that very little has been added to or removed from the original wiring of the plant.

The SIMATIC S7-300 and -400 series CPU's will be available as new through 2023 per the manufacturer website. Upon Siemens declaring these series of CPU's obsolete, parts will be available for an additional 10 years only.

Siemens offers migration solutions to upgrade aging CPUs to newer CPUs while either keeping the existing IO modules or replacing the IO modules with minimal downtime. The migration of the S7-300 series is not imminent but should start to be considered once Siemens announces the retirement of the S7-300 and -400 series.

Plant staff noted that they are currently unable to use their tablets while outside observing the main treatment process train as the WiFi does not extend far enough. Upgrading the plant WiFi infrastructure should be considered to allow for an expanded range of use for the tablets and improve system reliability and connectivity.

The filter consoles in the filter gallery are used as back up for backwashing filters and as a training tool for new operators. Operations normally initiate filter backwashes from the Operator

Workstation in the control room or by using a tablet, however, operations reports that there is very little maintenance for the filter consoles and they would like to keep them.

2.2.7.5 Summary of Priority Projects

The following is a summary of projects identified with their priority and category:

1. Generator controls (Class = 2, Category = M)
2. Main laboratory and BAC laboratory rehabilitation (Class = 3, Category = N)
3. Roof replacement (Class = 3, Category = N)
4. Mezzanine access and fall protection (Class = 3, Category = N)
5. HVAC replacement (Class = 3, Category = N)
6. UPS Room housekeeping (Class = 3, Category = M)
7. General electrical upgrades (Class = 1, Category = M)

2.2.8 Operations Building – Basement Level

The Pipe Gallery is located on the basement level of the Operations Building. It houses filter effluent, filter-to-waste, and backwash and air-scour piping, in addition to a majority of the plant's sample pumps and the air scour system for backwash. The Transfer Pump Station is also accessible from the Pipe Gallery.

2.2.8.1 Process Equipment

Air Scour Blower

The Air Scour Blower is nearing 20 years in-service but is in good working condition. WTP staff noted that water was infiltrating the pressure indicator and needed frequent bleed-outs. The cause of this is unknown however, as piping configuration should prevent this from occurring.

Gallery Valve Actuators

Plant staff stated that all valves were operational and in good condition. The valve actuators needed frequent repair or replacement. All actuators should be considered for replacement.

Sample Pumps

Sample Pump No. 1, Raw Water Sample Pump No. 2, Settled Water Sample Pump, Treated Water Sample Pump, and Composite Filtered Water Sample Pump are all located in the Pipe Gallery. All sample pumps are in good condition.

Sump Pump

The sump pump was not observed in operation. The pump and sump are equipped with multiple float switches but standing water was observed within the vault without triggering operation of the pump. Pump and float switches should be more thoroughly investigated to ensure system is operational.

2.2.8.2 Building Architectural & Structural

Architectural

The Pipe Gallery consists of sealed concrete surfaces, wall mounted sound-absorbing panels and is served by two stairwells from the Operations Building above.

Ponding of water was observed in both the Pipe Gallery and pump area. Some staining and discoloration of the concrete was present. Slight rust and corrosion were observed at the base of Stair B-135, but the general condition of the paint in the stair wells was good, with some accumulation of dirt and dust. The perimeter sealant of the doors serving the Pipe Gallery exhibited cracking and shrinkage.

2.2.8.3 Building Mechanical

HVAC

The HVAC equipment at the Operations Building-Pipe Gallery includes split-system air conditioning systems for ventilation and dehumidification.

Split-system AHU-3/ACCU-3 was not functioning in cooling/dehumidification mode at the time of the visit. The Pipe Gallery was slightly stagnant and humid. No condensation or corrosion was observed.

Selective replacement of HVAC equipment throughout the Operations Building is recommended. Refer to **Appendix F** for an HVAC replacement schedule. Equipment selection was based on condition and/or remaining useful service life.

Plumbing

The plumbing equipment at the Operations Building-Pipe Gallery includes drainage waste and vent piping, and washdown systems.

The plumbing visual inspection did not reveal any significant issues.

2.2.8.4 Instrumentation & Control

Instrumentation in the filter gallery is in good condition. The analyzers, differential pressure transmitters (for filter head loss and venturi flow measurement), chlorine analyzers, and turbidimeters are operational.

As mentioned previously, the HACH 1720E turbidimeters are considered by HACH to be obsolete and replacement with the newer TU5 model should be considered as part of an improvements project.

2.2.8.5 Summary of Priority Projects

The following is a summary of projects identified with their priority and category:

1. Replacement of turbidimeters (Class = 3, Category = O)
2. HVAC replacement (Class = 3, Category = N)

2.2.9 Operations Building - Chemical Storage

All chemical storage and feed systems are located in a separate wing of the Operations Building. An electrical room and generator room are also located in this wing.

2.2.9.1 Process Equipment

Caustic System

The caustic system consists of a 12,150-gallon bulk storage tank, 1,000-gallon day tank, two transfer pumps, and four feed pumps.

The bulk and day tanks were replaced in 2020 and are in good condition. Piping and valves within the bulk containment area were also replaced at the same time. Piping and valves in this area are in good condition but should be tightened as significant leakage and caustic buildup was observed. Transfer pumps and feed pumps are in poor condition, with significant corrosion and leakage observed. Full replacement of pumps, piping, valves, and appurtenances, excluding the bulk containment area, is recommended as a priority project.

Fluoride System

The fluoride system consists of a 6,000-gallon bulk storage tank, 100-gallon day tank, two transfer pumps, and two feed pumps.

The existing bulk and day tanks are both in good condition. As they are approaching 20 years in-service, they should be considered for replacement. The transfer pumps are approaching 20 years in-service. While still operational, they should also be considered for replacement due to their age. Fluoride Feed Pump No. 1 was originally a diaphragm pump, but it was replaced in 2020 with a peristaltic pump that is in good condition. Plant staff expressed desire to switch Feed Pump No. 2 out with a peristaltic pump to match Feed Pump No. 1

Aqua Ammonia System

The aqua ammonia system consists of a 6,000-gallon bulk storage tank, a vapor scrubber, and two feed pumps.

This system has never been used, and plant staff expressed the desire to remove or repurpose the system. The bulk storage tank is currently charged with chemical, but the product is aged, and efficacy is unknown. DHEC should be consulted to determine if system functionality will be required moving forward.

Lime System

The lime system consists of one 4,000-cubic-foot capacity lime silo, two 500-gallon slurry tanks with mixers, and five feed pumps.

During the condition assessment, the lime system was out-of-service as all feed pumps were being repaired/rebuilt. Due to their age, all feed pumps should be considered for replacement. The tank mixers were kept in-service to keep slurry within the tanks in suspension and are in good condition. The lime silo and slurry tanks both appeared to be in good condition. The volumetric feeders were not observed in operation but are assumed to be in good condition as staff did not make note of any problems.

Permanganate System

The permanganate system consists of two 3,000-gallon mixing tanks, a wand eductor system, and two feed pumps.

This system has never been used, and plant staff expressed the desire to remove or repurpose system. Storage tanks are in good condition and could be sold or donated. Functional status of the feed pumps is unknown, but they could be repurposed for use around the plant or used for spare parts.

Ferric System

The ferric system consists of two 12,250-gallon bulk storage tanks, 1000-gallon day tank, two transfer pumps, and three feed pumps.

The existing bulk tanks and day tank are in good condition. As they are approaching 20 years in-service, however, they should be considered for replacement. The transfer pumps are approaching 20 years in-service. While still operational, they should be considered for replacement due to their age.

Hypochlorite System

The hypochlorite system consists of two 15,000-gallon bulk storage tanks, a 2,000-gallon day tank, two transfer pumps, and four feed pumps.

The bulk and day tanks were replaced in 2020 and are in good condition. Hypo Tank No. 2 has not been charged with product since its replacement. Hypo Transfer Pump No. 2, which serves Hypo Tank No. 2, is new but has not yet been placed into service either. Hypo Transfer Pump No. 1 is nearing the end of its useful life and should be considered for replacement. Piping and valves within the bulk containment area were also replaced at the same time. As both transfer pumps are within the bulk containment area, they are at risk of flooding. Replacement with self-priming pumps should also be evaluated so that they can be moved out of the containment area. Three of the feed pumps are nearing 20 years in-service and may need to be replaced in the coming years due to their age. According to work order records provided by the plant, Hypo Feed Pump No. 4 was replaced within the last 5 years.

Polymer System

The polymer system consists of a liquid polymer batching system, two 2,000-gallon mixing and aging tanks, and three feed pumps. Each tank is equipped with one mixer. Polymer is delivered and stored in totes or drums on a designated concrete pad in the polymer area. Polymer is typically only fed during winter to promote coagulation and flocculation in colder water temperatures. The polymer system was not in use during the condition assessment.

The system was not observed in operation, but staff did not note any previous difficulties or issues with the system. The existing aging tanks and pumps appeared to be in good condition. All equipment is approaching 20 years in-service.

Chemical Sump Pumps

Each chemical system had a sump pump in the containment area (i.e. eight sump pumps in total). All sumps pumps must be manually turned on to prevent discharge of potentially hazardous

chemicals. None of the pumps were observed in operation, but they appeared to be in good condition. Staff stated that all sump pumps are functional.

Air Compressor

The air compressor system is used to supply air for the pneumatic valves in the lime feed system and sedimentation basin air lift pumps. The system was originally located in the Pipe Gallery, but the compressors were replaced in 2020 and the system relocated to the man hallway of the Chemical Storage wing. System was in good condition and functioning well.

2.2.9.2 Electrical Equipment

Refer to the Electrical Equipment discussion in Section 2.2.7.

2.2.9.3 Building Architectural & Structural

Architectural

The Chemical Storage section of the building contains dedicated storage rooms and/or containment areas for bulk storage tanks and feed pumps. The main Electrical Room and Generator Room are located at the west end of the building.

Overall, the building exhibits conditions expected for a building approaching twenty years of use storing corrosive and hazardous chemicals. Some improvements including the addition of removable skylights for tank removal, containment re-coating and door replacement were implemented recently for the Caustic, Fluoride and Sodium Hypochlorite Rooms.

Additional replacement of floor coatings is recommended in the Sodium Hypochlorite Room and in most feed pump or chemical storage areas. Extensive corrosion of the CMU base course in some spaces was observed as well as deterioration of the flooring system down to bare concrete.

The large storefront window systems throughout the containment areas exhibit some failure of window seals and perimeter joint sealants throughout for all exterior openings display signs of cracking and decay. Control joints throughout also exhibit cracking and loss of adhesion.

General condition of interior painting is satisfactory, but there are areas of extensive cracking and peeling as well as discoloration and staining and general buildup of dust and dirt.

Structural

As further discussed below, the replacement of CMU block in the chemical areas and recoating of the chemical areas is recommended as part of the improvements projects.

Caustic System

The metering pump area in the caustic room has severe deterioration of the coated surfaces and floor drain. The leakage is also traveling to the adjacent boiler room. The containment floor also does not appear to have positive drainage to the sump based on observations of residue deposits.

Fluoride System

The metering pump area in the fluoride system room has a severely deteriorated coating surface. The exposed metal roof surfaces also have minor corrosion.

Aqua Ammonia System

Evidence of previous roof leakage was observed in the aqua ammonia system room, which has led to coating failure of the concrete containment walls and discoloration of the painted CMU wall surfaces. Leakage through feed pipes has also resulted in severe toeboard deterioration and isolated deterioration of the coating system on the containment walls.

Lime System

The lime system silo support legs were observed to have coating loss. FRP grating was also observed to not be installed over a floor opening. Evidence of previous roof leakage was also observed, and unknown if actively leaking.

Permanganate System

The coating system in the permanganate system area was observed to be flaking in a few locations and standing water has also resulted in some coating loss.

Ferric System

The coated surfaces were observed to be deteriorated, most pronounced around the day tank and feed pumps. Leakage of hypochlorite through the adjoining CMU wall has also led to coating deterioration in the ferric system concrete containment walls and some damage to the CMU.

Hypochlorite System

The hypochlorite system metering pump leakage has resulted in severe deterioration of the coating around these pumps and deterioration of the CMU wall behind the pumps allowing leakage of the chemical into the adjacent ferric containment.

Polymer System

The coated surfaces appeared to be flaking in a few locations. It appeared to be limited to the top coat of the coating system.

Loading Area

Cracking in the CMU walls in the loading dock area was observed, mostly in the shared fire-rated wall separating the chemical systems.

2.2.9.4 Building Mechanical

HVAC

The HVAC equipment at the Operations Building – Chemical Storage includes roof mounted exhaust fans, hot water unit heaters, and split-system air conditioning units. Outside air for the ventilation systems is provided by intake air louvers with motor operated dampers.

The split-system air conditioning unit AHU-8/ACCU-8 was not functional, and back up emergency ventilation was being used. Air handling unit AHU-8 is badly corroded and not operational. Electrical room units AHU-9/10-ACCU9/10 are in fair condition but near the end of their useful lives. Most roof fans are in fair condition but nearing the end of their useful lives. The hot water unit heaters were observed to be in fair condition. All fans and controls should be tested to ensure they are functioning properly.

Selective replacement of HVAC equipment throughout the Operations Building is recommended. Refer to **Appendix F** for an HVAC replacement schedule. Equipment selection was based on condition and/or remaining useful service life. The Operations Building HVAC Replacement project presented in Section 2.3 encompasses equipment in all three areas of the building.

Code Updates

Although codes are not meant to be retroactive, codes are updated for health and safety and for best current design practices. Based on the International Mechanical Code, the current ventilation system controls do not meet the current requirements, although the general ventilation rates do meet and exceed the current ventilation rate requirements. Further building code evaluation can take place during final design.

Plumbing

The plumbing equipment at the Operations Building – Chemical Storage includes drain waste and vent piping, washdown hose stations, wall hydrants, emergency fixtures, and storm water system.

The freeze proof emergency shower outside the sodium hypo room was not functional, the valve was stuck, and unit would not function. The balance of the emergency fixtures were in fair condition, exhibiting some corrosion. It is recommended that flow sensors/alarms are installed on emergency fixtures as part of a priority project. Floor drains in many chemical rooms were in poor condition due to chemicals present.

2.2.9.5 Instrumentation & Control

PLC-5 is located in the hallway in the chemical area of the main plant down the hall from electrical room 143 and is in great condition. Level sensors/transmitters on bulk and day tanks as well as magnetic flowmeters on the discharge of the metering pumps appear to be operational. Analog and 120 VAC surge suppression has been provided on each device regardless of location (indoors or outdoors).

Field instrumentation in the chemical areas, except for the caustic room, is in very good condition. Pressure gauges on both the suction and discharge of all the chemical metering pumps appear to be not functional and are recommended to be replaced as part of the improvements projects.

2.2.9.6 Summary of Priority Projects

The following is a summary of projects identified with their priority and category:

1. Caustic room rehabilitation (Class = 1, Category = O)
2. Chemical area CMU replacement (Class = 3, Category = M)
3. Recoating of chemical areas (Class = 5, Category = M)
4. HVAC replacement (Class = 3, Category = N)
5. Eyewash/shower replacement and flow-switch addition (Class = 1, Category = N)
6. Pressure gauge replacement (Class = 4, Category = O)

2.3 Results

Table 2-6 presents a summary of the priority projects generated from the condition assessment findings, with their priority rating and functional category. A full list of equipment and their assessment rating is included in Appendix B - Condition Assessment Spreadsheet.

Table 2-6 Summary of Priority Projects

Discipline	Project	Level of Priority	Functional Category
Process Mechanical	Caustic Room Rehabilitation	1	O
Process Mechanical	Rehabilitation of Existing RWPS 1	2	O
Process Mechanical	Rehabilitation of Existing RWPS 2	2	O
Process Mechanical	Rehabilitation of Existing TPS	2	O
Process Mechanical	Rehabilitation of Existing FWPS	2	O
Process Mechanical	Replacement of Process Train Chain and Flights	2	O
Process Mechanical	Replacement of Process Train Valves and Gates	3	O
Building Mechanical	Finished Water Pump Station HVAC Replacement	3	N
Building Mechanical	Operations Building HVAC Replacement	3	N
Building Mechanical	RWPS 1 HVAC Replacement	3	N
Building Mechanical	RWPS 2 HVAC Replacement	3	N
Building Mechanical	Operations Building Eyewash/Shower Replacement & Flow-Switch Addition	1	N
Instrumentation and Controls	UPS Room Housekeeping	3	M
Instrumentation and Controls	PLC-1 and PLC-4 OIT Replacement	3	N
Instrumentation and Controls	Turbidimeter Replacement	3	O
Instrumentation and Controls	Pressure Gauge Replacement	4	O
Electrical	Generator Controls	2	M
Electrical	General Electrical Upgrades	1	M
Electrical	FWPS Replacement of VFDs	2	O
Electrical	RWPS 1 Replacement of VFDs	2	O
Electrical	RWPS 2 Replacement of VFDs	2	O
Electrical	TPS Replacement of VFDs	2	O
Architectural	RWPS 1 Roof Replacement	3	N
Architectural	RWPS 2 Roof Replacement	3	N
Architectural	FWPS Roof Replacement	3	N
Architectural	Operations Building Roof Replacement	3	N
Architectural	Main Lab and BAC Lab Rehab	3	N
Architectural	Chemical Area CMU Repair	3	M
Architectural	Operations Building Mezzanine Access and Fall Protection	1	N
Structural	Recoating of Chemical Areas	3	M
Structural	Recoating of the Process Train	3	M
Structural	RWPS 2 Canopy Recoating/Rehabilitation	3	M

Section 3

Plant Expansion

In conjunction with the condition assessment performed (see Section 2), CDM Smith has identified improvements necessary to expand the Pee Dee Regional WTP from the current 10.0 MGD up to 15.0 MGD permitted peak treatment capacity via uprating of the existing filters. This section details the necessary process, electrical, structural, mechanical, and instrumentation and control improvements necessary to support the expansion. As in Section 2, improvements have been grouped together by process area.

3.1 Raw Water Pump Station No. 1

3.1.1 Process Equipment

The existing raw water VTC pumps are rated for 4,000 gpm at 146 ft. TH each. The station is designed to operate in a two duty, one standby configuration, which equates to a pump station rated capacity of 8,000 gpm (11.52 MGD). The current installed firm capacity based upon the previously calculated maximum station system curve is 9,650 gpm (13.9 MGD).

CDM Smith reviewed the pump and system curves that were developed during the original design of the Pee Dee Regional WTP. **Figure 3-1** below depicts the combined pump and system curve for three pump operation.

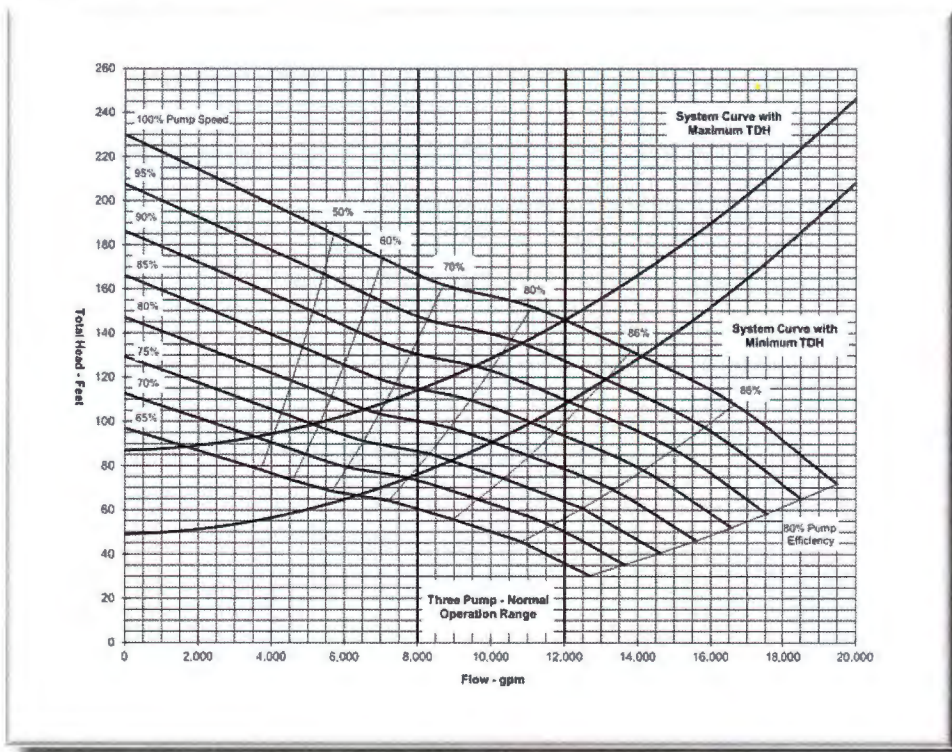

Figure 3-1
Raw Water Pump Station Combined Pump and System Curve – Three Pump Operation

By visual observation of the pump and system curve shown above, when utilizing three pumps, the existing pump station can pump up to 12,000 gpm (17.3 MGD) in maximum head system conditions. However, this estimated pumping capacity during three pump operation is based on the assumption that the pumps are in factory condition. The existing pumps utilize semi-open impellers, which require periodic routine maintenance to ensure the design pumping capacity and efficiency can be continually achieved.

As noted in Section 2 of this report, provisions were made in the original design to account for future plant capacity increases. These provisions include space for a future fourth VTC raw water pump, the addition of new T-screens connected to the steel raw water intake piping, and the ability to connect a second raw water main to the discharge header of the pump station. In order to maintain firm capacity and provide an increased plant flow of 15 MGD, a fourth pump would be installed in the raw water pump station. The existing T-screens have sufficient capacity to meet the increased flow without installation of new screen(s).

CDM Smith recommends conducting a flow test on the existing raw water pumps to identify current pumping capacities and to further verify the need for refurbishment and/or upgrade of the existing pumps. Prior to selecting a future fourth pump, or replacement of any of the existing pumps, CDM Smith recommends a full hydraulic analysis be conducted on the raw water pump station infrastructure. The hydraulic analysis should also include and review the impact of the addition of the second raw water pump station that was built in 2004 to maximize operational flexibility, optimize pumping efficiencies, and provide the most cost-effective solution for the plant upgrade. Additionally, the hydraulic analysis should consider if the second raw water main to the treatment plant is necessary. It is feasible to maintain acceptable velocity ranges (4-6 fps) within the existing single 30-inch raw water main routed from the station to the treatment plant with an increased pump station flow, but hydraulic modeling would need to factor in the results of the raw water pump station flow test to determine the impacts to system head conditions to make a firm conclusion.

3.1.2 Building Mechanical

HVAC

The HVAC equipment at the Raw Water Pump Station No. 1 includes roof-mounted exhaust fans and supply fan, electric unit heaters, and split system air conditioning units. Outside air for the upper level is provided by intake air louvers with motor operated dampers.

The existing split system air conditioning units were recently replaced and in good condition. For the expansion the unit's sizes will be verified to ensure they are adequate for and changes in the electrical load or pumping operating scheme.

The ventilation system needs to be verified that all fans are working (refer to the condition assessment report for general maintenance items for the ventilation systems). The ventilation system is assumed to be adequate, but an evaluation will be conducted to verify the sizing.

Plumbing

The plumbing equipment at the Raw Water Pump Station No. 1 includes drain waste and vent piping, washdown hose stations, wall hydrants, and storm water system.

No equipment upgrades required in these areas for the expansion.

3.1.3 Instrumentation & Control

The Raw Water Pump Station No. 1 communicates to the Water Treatment plant utilizing radio telemetry. PLC 1 is located in the pump station electrical room. The PLC has a hot-swappable processor and Input/Output (I/O) modules. There appears to be adequate spare I/O point on the existing modules to accept the fourth raw water pump.

Configuration would be required for both PLC-1 processors, the OIT associated with PLC-1, the redundant Ethernet switches, the raw water pump station radio telemetry unit and the operator workstation at the water plant Human Machine Interface (HMI) to add the fourth pump.

3.1.4 Electrical

The Raw Water Pump station's main power distribution equipment is MCC-1, rated 1600A and 480V. MCC-1 includes a section reserved for a fourth raw water pump – labeled "RWP-4". The maximum electrical demand recorded by the utility between June 2019 and May 2020 was 298kW, corresponding to approximately 450A of load assuming a power factor of 0.8; these calculations indicate sufficient capacity to support the fourth pump.

3.2 Raw Water Pump Station No. 2 and Reservoir

3.2.1 Process Equipment

The existing raw water pump station No. 2 VTC pumps are rated for 11,000 gpm (15.84 MGD) at 30 ft. TH each. The station is designed to operate in a single duty, one standby configuration, which equates to a pump station rated capacity of 11,000 gpm (15.84 MGD). The current installed firm capacity based upon the previously calculated maximum station system curve is 13,000 gpm (18.7 MGD).

CDM Smith reviewed the pump and system curves that were developed during the design of the raw water reservoir and pump station. **Figure 3-2** below depicts the combined pump and system curve for one pump operation.

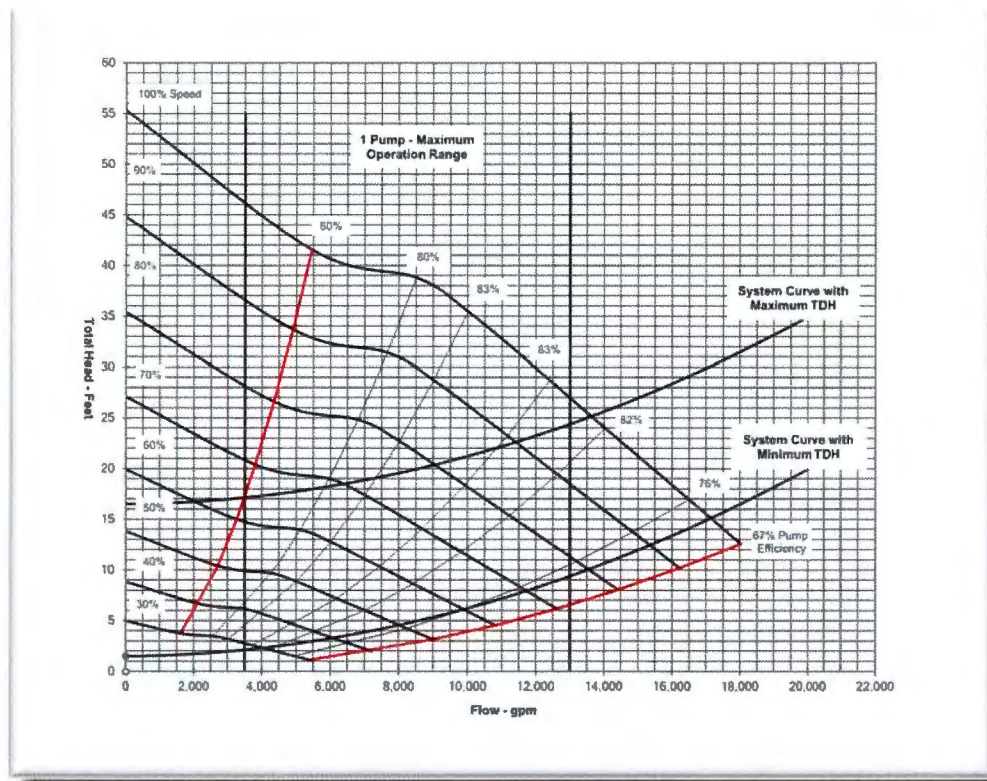

Figure 3-2
Raw Water Pump Station No. 2 Combined Pump and System Curve – One Pump Operation

By visual observation of the pump and system curve shown above, when utilizing a single pump, the existing pump station can pump up to 13,000 gpm (18.7 MGD) in maximum head system conditions. However, this estimated pumping capacity during one pump operation is based on the assumption that the pumps are in factory condition

As noted in Section 2 of this report, provisions were made in the original design to account for future plant capacity increases. These provisions include space for a future third VTC raw water pump. Considering that with a single pump in operation the Raw Water Pump Station No. 2 can pump up to 13,000 gpm (18.7 MGD) at maximum system conditions, it likely wouldn't be necessary to install the third future pump to achieve a total plant capacity of 15 MGD. The overall plant efficiency and flow balance including backwash volumes and frequency would need to be evaluated further to verify this. The consideration to add an additional pump at Raw Water Pump Station No. 2 is not as critical given that Raw Water Pump Station No. 1 provides redundancy to the system by being able to bypass the reservoir and pump directly to the plant. Continued use of the reservoir is encouraged, however, as it improves raw water quality by providing additional settling.

CDM Smith recommends conducting a flow test on the existing raw water pumps to identify current pumping capacities and to further verify the need for refurbishment and/or upgrade of the existing pumps. Prior to confirming the need for the third future pump, or replacement of any of the existing pumps, CDM Smith recommends a full hydraulic analysis be conducted on the raw water pump station infrastructure. The hydraulic analysis should also include the current and

future pumping operational strategy for both raw water pump stations to maximize operational flexibility, optimize pumping efficiencies, and provide the most cost-effective solution for the plant upgrade.

3.2.2 Building Mechanical

HVAC

The HVAC equipment at the Raw Water Pump Station No. 2 includes split system air conditioning units.

The existing air conditioning units are in fair condition, but near the end of their useful lives and there were issues with the condensate draining. With the expansion, the HVAC system sizing should be evaluated to ensure that current sizes are adequate for any additional heat load from the electrical gear associated with change in the Raw Water pumps operation. It is recommended that the air conditioning unit sizes will need to be increased to handle the increased heat load from an additional large pump VFD.

3.2.3 Instrumentation & Control

The Raw Water Pump Station 2 communicates to the Water Treatment plant utilizing Ethernet protocol over fiber optic cable. PLC 6 is located in the pump station electrical room. The PLC has a hot-swappable processor and Input/Output (I/O) modules. There is one spare I/O module slot in the I/O module rack however, there appears to be adequate spare I/O point on the existing modules to accept the third raw water pump, as deemed necessary based on the existing pump flow testing.

Configuration would be required for both PLC-6 processors, the OIT associated with PLC-6, redundant Ethernet switches and the operator workstation at the water plant Human Machine Interface (HMI) to add the third pump if required.

3.2.4 Electrical

The Raw Water Pump Station 2's main power distribution equipment includes MCC-3A and MCC-3B, both rated 800A and 480V, and each feeding one Raw Water Pump. MCC-3A includes a section reserved for a third raw water pump – labeled "RWP-3" along with multiple additional spares and spaces. The power quality meters installed at MCC-3A and MCC-3B were not operational at the time of CDM Smith's site visit, however, given the substantial number of spare feeder units and the space already reserved for a third pump, it is assumed that sufficient electrical capacity is available to support the expansion.

3.3 Treatment Process Train

3.3.1 Process Equipment

During the initial plant design (CDM Smith 1999), the existing rapid mix basins, flocculation basins, sedimentation basins, and filter units were grouped together as a contiguous 'treatment module.' The plant was designed with the intent to accommodate the expansion to 15 MGD with only the one original treatment module in service; expansion beyond 15 MGD would require construction of additional, identical treatment modules.

However, the expansion to a permitted capacity of 15 MGD will require regulatory exemptions and accommodations from the South Carolina Department of Health and Environmental Control (DHEC). A summary of the velocity, detention time, and loading rate requirements established by DHEC are listed in **Table 3-1**.

Table 3-1 Summary of Regulatory Requirements

Parameter	DHEC Requirement
Flocculation	
Basin flow-through velocity (fpm)	0.5 – 1.5
Effluent channel/pipe flow through velocity (fps)	0.5 – 1.5
Minimum detention time (min.)	30
Sedimentation	
Maximum basin flow-through velocity (fpm)	0.5
Minimum detention time (hrs.)	4.0
or Maximum tube settler application rate (gpm/sf) ^{1, 2}	2.0
or Maximum plate settler application rate (gpm/sf) ¹	0.5
Filtration	
Maximum influent channel/pipe flow through velocity (fps)	2.0
Maximum loading rate (gpm/sf)	4.0

¹ Neither tube settlers nor plate settlers are currently installed within the plant sedimentation basins.

² Square footage is based on 80% of the projected horizontal plate area

At its current permitted capacity of 10 MGD, the Pee Dee Regional WTP does not meet flocculation basin flow-through velocity, flocculation basin effluent flow-through velocity, or sedimentation basin max flow-through velocity per DHEC requirements. DHEC granted exceptions to these parameters during the initial plant design. At the expansion to 15 MGD, with only one treatment module online, the Pee Dee Regional WTP would also no longer meet the flocculation minimum detention time, sedimentation basin minimum detention time, or maximum filter loading rate per DHEC requirements.

Tube or plate settlers can be installed in the sedimentation basins to fulfill regulatory requirements for detention time with high-rate clarification requirements for loading rate. Filter loading rates above 4.0 gpm/sf may be approved by DHEC, following performance of a filter uprating study. Refer to the *Plant Expansion to 15 MGD and Review of State Regulatory Requirements Technical Memorandum* (CDM Smith, September 2020) in **Appendix D** for additional information and discussion.

CDM Smith and the City met with DHEC on October 16, 2020 to have a preliminary discussion on the plant expansion and filter uprating study (refer to **Appendix E** for meeting minutes). At the meeting, DHEC gave verbal approval of the reduced detention times in the flocculation basins and addition of tube or plate settlers to the sedimentation basin at 15 MGD. In order to move forward with the expansion design as set out in this section, formal confirmation from DHEC should be obtained. DHEC stated that approval for the filter uprating study is contingent upon uprating plan approval and having excess capacity (i.e., the plant has not reached 80% capacity for any monthly average). The filter uprating plan, design and construction schedule, and flow projections will be assembled and submitted as a part of a future authorization.

At this time, it is not anticipated that any other upgrades to existing process equipment (i.e., mixers, flocculators, chain and flight) will be required to support plant expansion (beyond what has been identified in the condition assessment in Section 2). Tube settlers or plate (lamella) settlers are therefore the only new process equipment expected in the treatment process train as a result of the plant expansion. Other advanced clarification technologies, such as Superpulsators shall be considered as a part of detailed design.

The installation of settlers serves to increase the effective solids settling area and reduce the distance in which a suspended particle must “fall”, allowing for higher flow rates through the basins in which they are installed. Both settler types are commonly used in the water and wastewater industries for advanced clarification. Settlers can be retrofitted within the plant’s existing sedimentation basins and will not interfere with the chain and flight system used for sludge removal. In addition to the tubes or plates, installation generally requires structural support, baffle walls, and an effluent launder system. Once a full hydraulic evaluation of the plant is done, it may be determined that basin walls should be raised to allow sufficient driving head through the sedimentation basins. Full consideration of all structural modifications will be performed as a part of detailed design. **Figure 3-3** shows a typical tube settler installation, and **Figure 3-4** shows a typical plate settler installation.

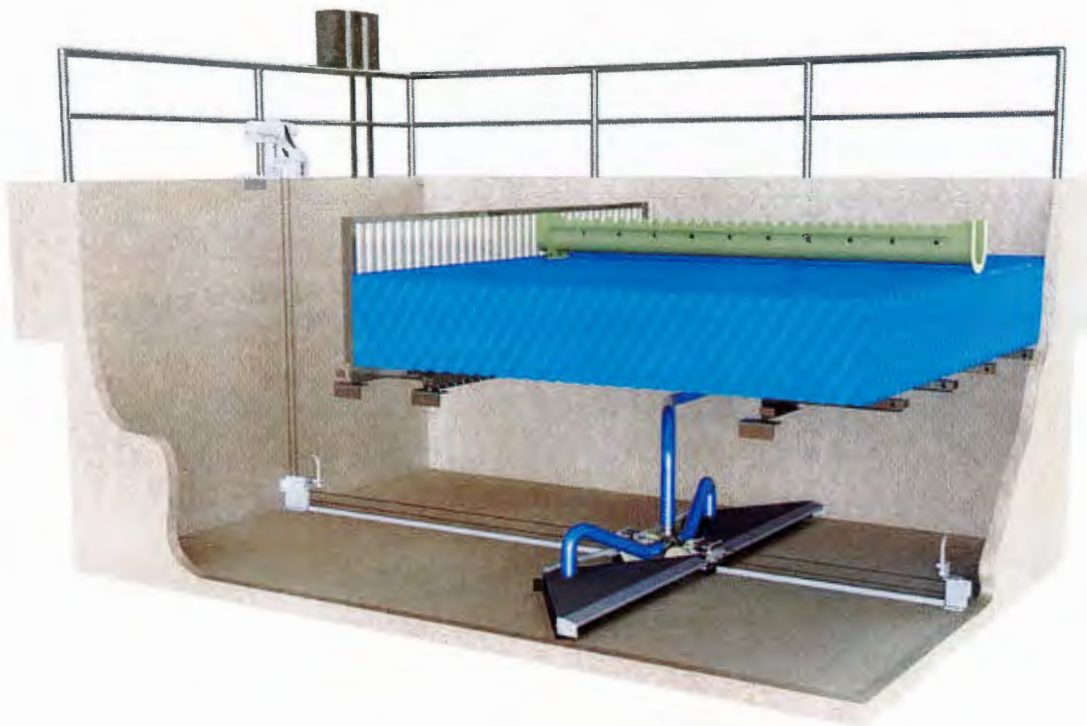

Figure 3-3
Tube Settler Installation Example (Image courtesy of Brentwood Industries, Inc.)

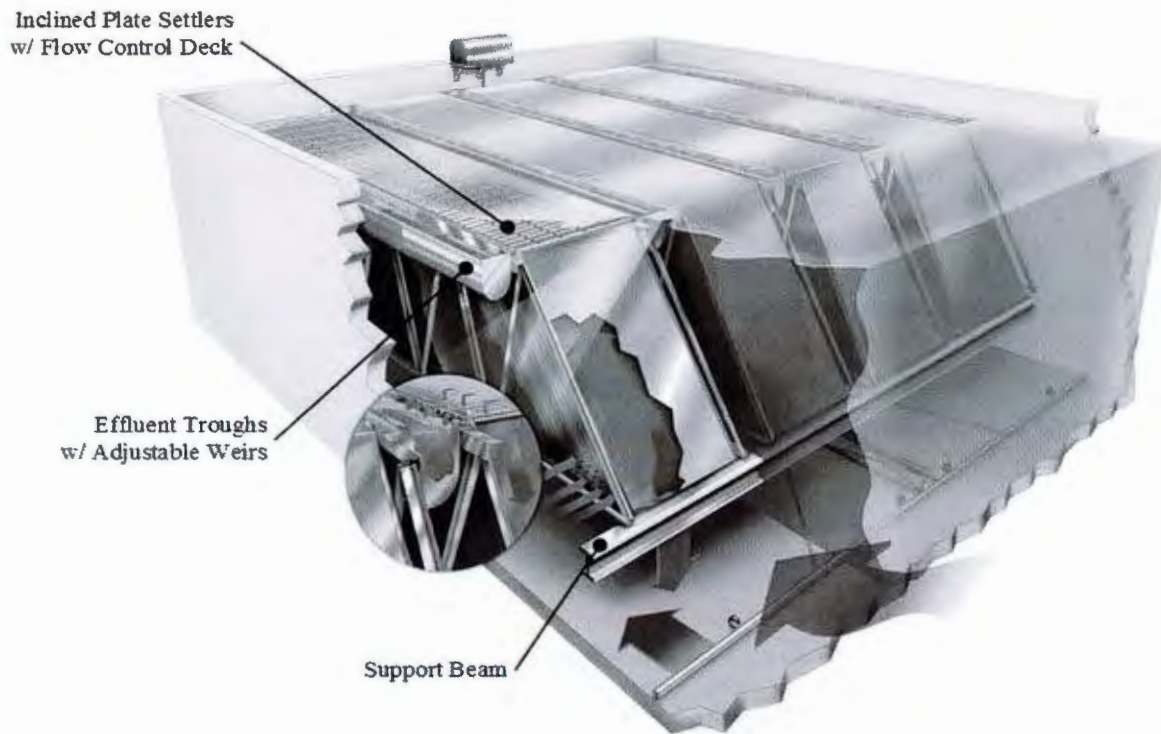

Figure 3-4
Plate Settler Installation Example (Image courtesy of Meurer Research, Inc.)

3.3.2 Instrumentation & Control

The Treatment Process Train PLC 2 communicates to the Water Treatment plant utilizing Ethernet protocol over fiber optic cable. PLC 2 is located in the electrical room 148 within the main treatment building. The PLC has a hot-swappable processor and Input/Output (I/O) modules. There are several spare I/O module slots in the I/O module rack however, there appears to be adequate spare I/O points on the existing modules to accept additional I/O.

Configuration would be required for both PLC-2 processors, the OIT associated with PLC-2, redundant Ethernet switches and the operator workstation at the water plant Human Machine Interface (HMI) to add any additional instrumentation or vendor provided equipment for the treatment train if required.

3.3.4 Electrical

Power is supplied to the treatment process train through a combination of electrical equipment, including switchgear, MCCs, and panelboards. While some of the panelboards have limited available spares and/or spaces, new subpanels could be installed as necessary to provide new circuits. New or upgraded electrical loads added to the process train would require confirming sufficient electrical capacity is available to power such loads.

3.4 Transfer Pump Station and Storage

3.4.1 Process Equipment

3.4.1.1 Transfer Pumps

The existing transfer pump station pumps are rated for 5,250 gpm (7.56 MGD) at 57 ft. TH each. The station is designed to operate in a two duty, one standby configuration, which equates to a pump station rated capacity of 10,500 gpm (15.12 MGD). The current installed firm capacity based upon the previously calculated maximum station system curve is 10,750 gpm (15.5 MGD).

CDM Smith reviewed the pump and system curves that were developed during the design of the of the original Pee Dee WTP. **Figure 3-5** below depicts the combined pump and system curve for two pump operation.

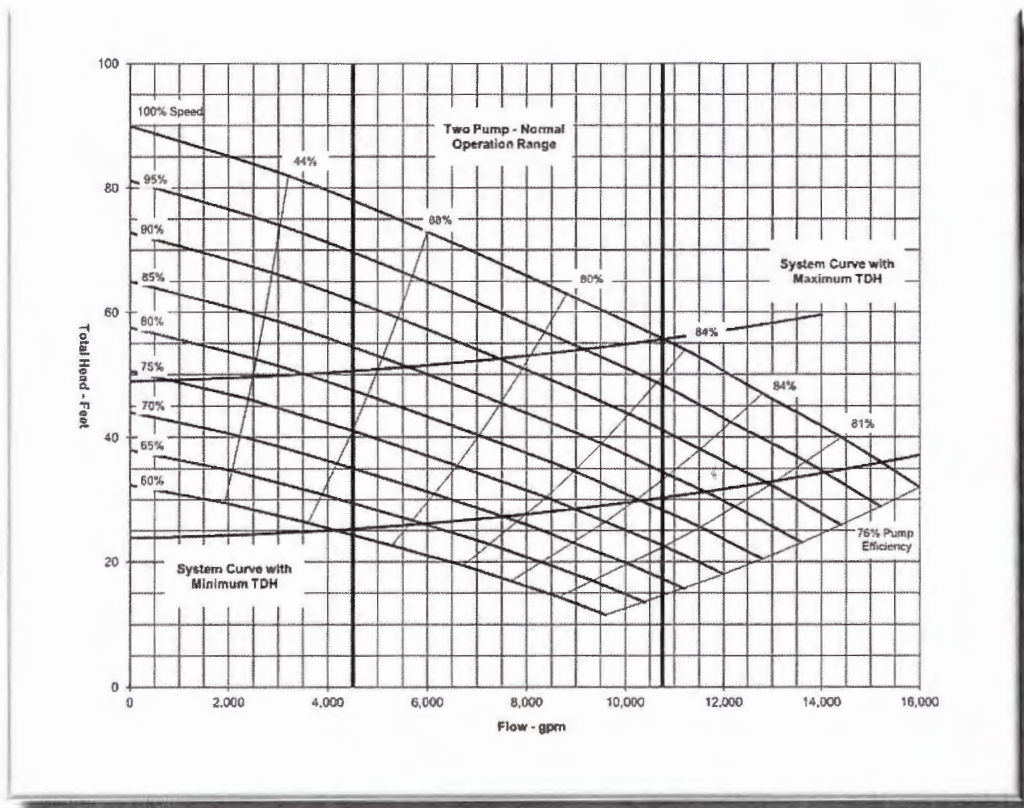

Figure 3-5
Transfer Pump Station Combined Pump and System Curve – Two Pump Operation

By visual observation of the pump and system curve shown above, when utilizing two pumps the existing pump station can pump up to 10,750 gpm (15.5 MGD) in maximum head system conditions. This is sufficient to meet the required flow rate for a filter capacity of 15 MGD. Pump flow tests should be conducted to ensure that this flow capacity is still achievable by the pumps. Should this capacity not be met, replacement of one or more of the existing pumps will be required; higher capacity pumps should be considered to provide a greater firm capacity at that time.

As noted in Section 2 of this report, the original design did not include space for a future fourth pump, but it appears provisions were made in the original design to account for future plant capacity increases. These provisions include a wetwell and initial suction piping size that could accommodate the installation of a new vertical dry pit solids handling pumps with increased pumping capacity.

The existing transfer pumps are not NSF 61 certified for the production of potable water. Replacement solids handling pumps are not commercially available with an NSF 61 certification; however, the pumps can be made with NSF compliant internal materials and coatings. Other pump types considered included vertical inline pumps and vertically mounted axially split case pumps. Vertically mounted axially split case pumps are an NSF 61 certified option, but this pump type would require significant piping layout and structural modifications. The proposed use of solids handling pumps was discussed with DHEC, and their use will likely be acceptable, however, this needs to be confirmed as the project moves forward. Reference **Appendix E** for meeting minutes with DHEC.

CDM Smith recommends a full hydraulic analysis be conducted on the transfer pump station infrastructure. The hydraulic analysis should also include the necessary piping and operational modifications that would be required for a new clearwell to be installed.

3.4.1.2 Additional Clearwell Tank

The plant's existing clearwell (1.92 MG volume) stores finished water prior to being pumped to the distribution system. In addition to providing storage volume for disinfection, the clearwell also serves as the backwash water source for the filters. Washwater is supplied through a 24-inch backwash header that originates near the finished water pump station.

The initial plant design allocated space for four identical 2 MG clearwell tanks – one for initial plant construction and three for future expansions. For the expansion to 15 MGD, it is recommended that one additional 2 MG clearwell tank is constructed to increase finished water storage capacity and redundancy for maintenance. This increased capacity meets the plant's operational needs including disinfection requirements and filter backwash supply at 15 MGD. Other water storage requirements, including Diurnal Equalization and Emergency demands, should be further evaluated during detailed design. Design criteria for the new tank is presented in **Table 3-2**.

Table 3-2 Design Criteria for New Clearwell Tank

Parameter	Value
Construction Material	Prestressed Concrete
Design Volume (MG)	1.92
Inner Diameter (ft.)	110
Maximum Side Water Depth (ft.)	27
Baffle Type	Shotcrete, circular

Disinfection Contact Time

EPA's Surface Water Treatment Rule (SWTR) and South Carolina Primary Drinking Water Regulations (Regulation 61-58) require at least 99.9 percent (3-log) removal and/or inactivation of *Giardia*, at least 99.99 percent (4-log) removal and/or inactivation of viruses, and at least 99 percent (2-log) removal of *Cryptosporidium*. As a conventional filtration plant, the Pee Dee WTP receives filtration credits of 2.5-logs for *Giardia*, 2-logs for viruses, and at least 2-logs for *Cryptosporidium*. This assumes that the plant's filter effluent continues to meet the turbidity level requirements set by the State (a monthly 95th percentile value of less than 0.3 NTU). As such, the Pee Dee Regional WTP's inactivation requirements for the disinfection process are 0.5-logs for *Giardia* and 2-logs for viruses.

Table 3-3 presents the design criteria used to calculate the minimum operating volume to achieve the required inactivation of *Giardia* and viruses. It should be noted that conservative values for pH, temperature, and chlorine residual are used to determine the CT requirement. Values were obtained from plant monthly operating report (MOR) data spanning January 2017 to May 2020. The CT requirement for *Giardia* controls the volume required.

Table 3-3 CT Requirements for Providing Disinfection in New Clearwell No. 2

Parameter	Value
Log Inactivation Required for <i>Giardia</i>	0.5
Log Inactivation Required for viruses	2.0
Maximum Clearwell pH	8.5
Minimum Water Temperature (°C)	6.0
Minimum Residual Cl ₂ Concentration (mg/L)	0.8
CT required for 0.5-log <i>Giardia</i> inactivation at 6.0 °C, pH = 9.0, 0.8 mg/L Cl ₂ (min-mg/L)	40.0
CT required for 2.0-log virus inactivation at 6.0 °C, pH = 9.0, 0.8 mg/L Cl ₂ (min-mg/L)	3.8
Design Flow (mgd)	15
Baffling Factor	0.4 ¹
Total Detention Time (min)	125.0
Minimum Clearwell Volume to meet CT Requirement (gal)	1,300,000

¹ Assumes perforated inlet baffle, serpentine or perforated intra-basin baffles, outlet weir or perforated launders.

The new clearwell will need to maintain approximately 1.30 MG of storage if used to meet the CT requirement with Clearwell No. 1 offline. Tracer testing must be performed on the new clearwell to determine the actual baffling factor.

Filter Backwash Supply

In addition to meeting disinfection requirements, the new clearwell must also be able to provide adequate backwash water, assuming Clearwell No. 1 is offline. The plant typically performs one backwash per day, with each backwash using up to 94,000 gallons of finished water. **Table 3-4** presents the remaining storage available in Clearwell No. 2 after the CT requirement is met and with storage reserved for up to three backwashes to be conservative.

Table 3-4 Clearwell Storage Remaining after CT Requirement and Filter Backwash

Description	Water Depth (ft)	Volume (MG)
Clearwell Design (Available Storage)	26.95	1.92
CT Requirement	18.31	1.30
One Backwash	1.32	0.09
Two Backwashes	2.64	0.19
Three Backwashes	3.96	0.28
Remaining Storage with One Backwash	7.32	0.52
Remaining Storage with Two Backwashes	6.00	0.43
Remaining Storage with Three Backwashes	4.68	0.33

3.4.2 Structural

As expressed by the plant staff during the condition assessment, the existing infrastructure in place for the installation and removal of the existing Transfer Pumps is insufficient to meet current needs. Current provisions include a 4'x4' access hatch adjacent to the existing Transfer Pumps with no installed lifting system in the building. The existing Transfer Pump footprint is understood to be larger than the existing 4'x4' hatch.

As part of upsizing the Transfer Pumps, it is proposed that the existing concrete deck above the Transfer Pumps be further reinforced with concrete columns and steel beams in order to cut out 6'x6' access hatches above each new Transfer Pump. A hoisting system such as a gantry crane or monorail shall be considered to lift the Transfer Pumps from the floor below through the new hatches and then removed from the building through the adjacent loading dock. The structural modifications and lifting system shall be further evaluated as part of detailed design.

3.4.3 Instrumentation & Control

The existing transfer pumps are connected to PLC-2. Please see Section 3.2.3 for recommendations regarding any additional I/O requirements to the existing raw water 2 pumps or any additional instrumentation.

The Finished Water Pump Station PLC 4 communicates to the Water Treatment plant utilizing Ethernet protocol over fiber optic cable. PLC 2 is located in the electrical room within the Finished Water Pump Station. The PLC has a hot-swappable processor and Input/Output (I/O) modules. There are several spare I/O module slots in the I/O module rack however, there appears to be adequate spare I/O point on the existing modules to accept additional clearwell level signals and any other instrumentation required.

Configuration would be required for both PLC-4 processors, the OIT associated with PLC-4, redundant Ethernet switches and the operator workstation at the water plant Human Machine Interface (HMI) to add any additional instrumentation or vendor provided equipment if required.

3.4.4 Electrical

The existing transfer pumps are powered from the MCC-1A and MCC-1B, each rated 1200A and 480V. Transfer Pumps No. 1 and No. 3 are fed from MCC-1A, while MCC-1B feeds Transfer Pump No. 2. The power quality meter installed at MCC-2A was not operational at the time of CDM

Smith's site visit, however, the meter at MCC-1A recorded a maximum current of 762A. Increasing the transfer pump sizes from 100HP to 125HP each corresponds to an additional load of approximately 70A on MCC-1A and 35A on MCC-1B. Provided the loading of MCC-1B is similar to that of MCC-1A, it is assumed that sufficient electrical capacity is available to support the expansion.

3.5 Finished Water Pump Station

3.5.1 Process Equipment

The existing finished water VTC pumps are rated for 3,500 gpm at 255 ft. TH each. The station is designed to operate in a two duty, one standby configuration, which equates to a pump station rated capacity of 7,000 gpm (10.08 MGD). The current installed firm capacity based upon the previously calculated maximum station system curve is 7,500 gpm (10.8 MGD).

CDM Smith reviewed the pump and system curves that were developed during the original design of the Pee Dee WTP. **Figure 3-6** below depicts the combined pump and system curve for three pump operation.

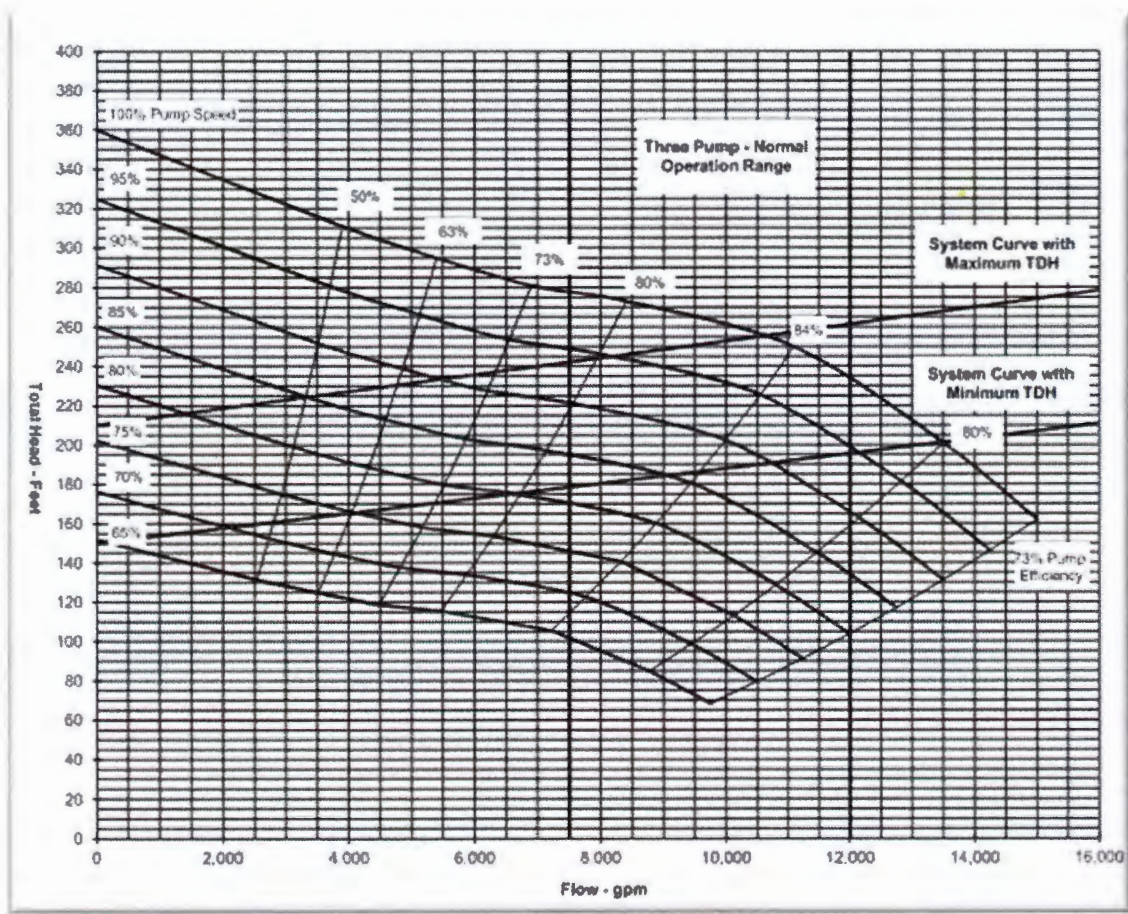

Figure 3-6
Finished Water Pump Station Combined Pump and System Curve – Three Pump Operation

By visual observation of the pump and system curve shown above, when utilizing three pumps, the existing pump station can pump up to 10,500 gpm (15.12 MGD) in maximum head system conditions. However, this estimated pumping capacity during three pump operation is based on the assumption that the pumps are in factory condition.

As noted in Section 2 of this report, provisions were made in the original design to account for future plant capacity increases. These provisions include space for a future fourth VTC finished water pump. In order to maintain firm capacity and provide an increased plant flow of 15 MGD, a fourth pump would need to be installed in the finished water pump station.

CDM Smith recommends conducting a flow test on the existing finished water pumps to identify current pumping capacities and to further verify the need for refurbishment and/or upgrade of the existing pumps. Prior to selecting a future fourth pump, or replacement of any of the existing pumps, CDM Smith recommends a full hydraulic analysis be conducted on the finished water pump station infrastructure. The hydraulic analysis should include any piping and operational strategy modifications that would need to be made should a second clearwell be constructed.

3.5.2 Building Mechanical

HVAC

The HVAC equipment at the Finished Water Pump Station includes roof-mounted exhaust fans, electric unit heaters, and split system air conditioning units. Outside air for the pump room is provided by intake air louvers with motor operated dampers.

The existing split system air conditioning units were recently replaced and in good condition. For the expansion the unit's sizes will be verified to ensure they are adequate for and changes in the electrical load or pumping operating scheme.

The ventilation system needs to be verified that all fans are working, refer to the condition assessment report for general maintenance items for the ventilation systems. The ventilation system is assumed to be adequate, but an evaluation will be conducted to verify the sizing.

Plumbing

The plumbing equipment at the Finished Water Pump Station includes drain waste and vent piping, washdown hose stations, wall hydrants, and storm water system.

No equipment upgrades required in these areas for the expansion.

3.5.3 Instrumentation & Control

The existing finished water pumps are connected to PLC-4. Please see Section 3.4.3 for recommendations regarding any additional I/O requirements for the addition of a second clearwell. There is adequate I/O space utilizing either existing I/O modules or adding additional I/O modules to accommodate the addition of a fourth finished water pump.

3.5.4 Electrical

The existing finished water pumps are powered from the MCC-2A and MCC-2B, each rated 1200A and 480V. Transfer Pumps No. 1 and No. 3 are fed from MCC-2A, while MCC-2A feeds Transfer Pump No. 2 and includes a reserved space for Transfer Pump No. 4. The power quality meters for

MCC-2A and MCC-2B recorded maximum demands of 601A and 523A respectively. As such, there is sufficient spare capacity to support the plant expansion.

3.6 Recycle Pump Station

3.6.1 Process Equipment

As discussed in Section 2.0 of this report, the Recycle Pump Station currently conveys process wastewater to the Florence Regional Wastewater Management Facility rather than recycling supernatant to the head of the plant. The initial plant design provided space for one additional recycle pump.

Based on an initial analysis performed by CDM Smith, the existing recycle pumps will provide sufficient capacity to handle the process wastewater generated at the plant's expansion to 15 MGD. It is not anticipated that installation of the fourth recycle pump will be required. However, further investigation and analysis using a larger dataset will be necessary as part of detailed design.

The plant currently has a permit to discharge 160,000 gpd of process wastewater to the Florence Regional Wastewater Management Facility. Based on the initial analysis performed, this permit will need to be revisited as current wastewater production is nearing the 160,000 gpd limit.

3.6.2 Instrumentation & Control

The existing recycle pumps are connected to PLC-6. Please see Section 3.2.3 for recommendations regarding any additional I/O requirements for adding an additional pump to the Raw Water Pump Station 2 or adding an additional recycle pump if required.

3.6.4 Electrical

The existing recycle pumps are powered from the Recycle Pump Control Panel, which is in turn fed from MCC-2B. As discussed above, there is sufficient spare capacity to support the plant expansion.

3.7 Operations Building – Ground Level

3.7.1 Building Architectural & Structural

As discussed in Section 2 of this report, plant staff indicated that the existing lab and BAC lab in the Operations Building was considered to be tight on space and equipment, particularly when the plant's groundwater staff is using the facility simultaneously. Based on discussions with the City, the existing lab office and office space adjacent to the lab office are not being used. As a part of the plant expansion, it is proposed that existing lab office and adjacent office space be repurposed as an expansion of the existing lab facility by approximately 300-square-feet. Further evaluation of the lab expansion features shall be considered as a part of detailed design.

Similar discussions with plant staff suggested that additional maintenance space, configured for larger work areas and tool usage was desired due to the limitations of the existing Maintenance Shop in the Operations Building. Based on discussions with the City, a new maintenance building could be considered on site. Upon preliminary evaluation of existing site utilities, there are three potential locations on site that could accommodate a new 1300-square-foot maintenance facility,

which would be approximately twice the size of the existing Maintenance Shop. The first potential location to be considered would be located on the area to the North of the existing Operations Building, adjacent to the northernmost plant road for garage access to the facility. Another potential location that could be considered would be across the existing Clearwell Tank No. 1, just North of the future Ozone Facility. Again, this location would also be located adjacent to the plant road just East of the existing Clearwell Tank No. 1 for garage access to the facility. The other location for consideration would be located southeast of the existing Operations Building along the easternmost plant road for garage access. This location would require relocation of some existing utilities. Further evaluation of the new maintenance facility location, size, and features shall be considered as a part of detailed design.

3.7.2 Instrumentation & Control

There are three (3) existing SCADA servers currently located in the UPS room adjacent to the control room. Configuration of the SCADA servers and data historian would be required when additional equipment or instrumentation is added to the plant.

The operator workstation HMI software (iFix) would be required to be updated to include any new process equipment as well as alarms and trends. Operator workstations in the control room as well as OITs in the lab area and three (3) SCADA tablets would also require updating with additional equipment or instrumentation.

No additional hardware (SCADA servers, operator workstations, displays) would be required for the plant expansion.

3.8 Operations Building – Basement Level

3.8.1 Building Mechanical

HVAC

The HVAC equipment at the basement level includes split system air conditioning systems for ventilation and dehumidification.

The existing split system AHU-3/ACCU-3 serves the pipe gallery and transfer pump area, this equipment sizing needs to be verified for any additional heat load or pumps. It is recommended to provide a split system dehumidification unit for space conditioning, sized for moisture removal and cooling of the transfer pumps.

Plumbing

The plumbing equipment at the basement level includes drainage waste and vent piping, and washdown systems.

No equipment upgrades required in these areas for the expansion.

3.9 Operations Building – Chemical Facilities

3.9.1 Process Equipment

CDM Smith has examined historical chemical consumption and dosage information to determine the required bulk storage, day storage, and metering pump capacities for an expansion from 10 MGD to 15 MGD.

South Carolina requires that water treatment plants provide storage for thirty days of chemical (i.e., bulk storage). At average dose and the future average flow, only the plant's existing Ferric bulk storage tanks and Caustic bulk storage tank fail to meet this requirement. At their existing sizes, they would provide 24 days and 28 days, respectively. During the October 16, 2020 meeting with CDM Smith, the City, and DHEC (refer to Section 3.3.1 and Appendix E for additional information), DHEC indicated that they would not likely require construction of additional bulk storage due to the plant's proximity to I-95 and ability to quickly receive additional supply. This should be formally confirmed as the project moves forward.

If additional storage is ultimately required, the permanganate storage and feed system, which has never been used, can be potentially removed (see Section 2 for further discussion) and this space can be repurposed to accommodate a new 12,000 gallon ferric bulk storage tank. The permanganate containment area abuts the existing ferric day tank storage and metering pump area. An additional transfer pump and associated piping, valves, and appurtenances will be required to accommodate placement of the tank and integrate it into the existing feed system.

There are no stated requirements for day tanks other than that they are provided for all liquid chemicals on-site. At average dose and the future average flow, all day tanks on-site will still provide a minimum of 24 hours of chemical supply. Additionally, all existing chemical metering pump flow capacities are sufficient to provide maximum chemical does at the maximum future plant flow of 15 MGD. No additional equipment is therefore required to accommodate the expansion.

Refer to the *Plant Expansion to 15 MGD and Review of State Regulatory Requirements Technical Memorandum* (CDM Smith, September 2020) in Appendix D for additional information and discussion.

3.9.2 Building Mechanical

HVAC

The HVAC equipment at the Operations Building – Chemical Facilities includes roof-mounted exhaust fans, hot water unit heaters, and split system air conditioning units. Outside air for the ventilation systems is provided by intake air louvers with motor operated dampers.

The ventilation system will be evaluated based on the amount and quantities of any new chemicals.

Plumbing

The plumbing equipment at the Operations Building – Chemical Facilities includes drain waste and vent piping, washdown hose stations, wall hydrants, emergency fixtures, and storm water system.

Reconfiguration of the emergency shower around new and existing chemical tanks will be evaluated for this expansion project. Floor drainage will be evaluated based on the layout of any new bulk chemical storage changes.

3.9.3 Instrumentation & Control

All Chemical systems are connected to PLC 5 located in the hallway adjacent to the chemical storage and feed rooms. PLC 5 communicates to the Water Treatment plant utilizing Ethernet protocol over fiber optic cable. The PLC has a hot-swappable processor and Input/Output (I/O) modules. There are several spare I/O module slots in the I/O module rack that can be utilized if additional ferric transfer pump signals or any other instrumentation is required.

Configuration would be required for both PLC-5 processors, the OIT associated with PLC-5, redundant Ethernet switches and the operator workstation at the water plant Human Machine Interface (HMI) to add any additional instrumentation or vendor provided equipment if required.

3.9.4 Electrical

Power is supplied to the chemical facilities through a combination of electrical equipment, including switchgear, MCCs, and panelboards. While some of the panelboards have limited available spares and/or spaces, new subpanels could be installed as necessary to provide new circuits. New or upgraded electrical loads added to the chemical facilities would require confirming sufficient electrical capacity is available to power such loads.

3.10 Summary of Required Projects for Expansion

Table 3-5 presents a summary of the capital projects required in order for the plant to expand and achieve a permitted capacity of 15 MGD. In addition to the capital projects, several engineering/operations studies and evaluations are required for expansion – a filter uprating study, a sedimentation basin unit settler pilot study (if necessary based on results of filter uprating study), flow testing of pumps, and a full plant hydraulic profile evaluation.

Table 3-5 Summary of Expansion Projects

Discipline	Project
Process Mechanical	RWPS 1 Raw Water Pump Addition
Process Mechanical	FWPS Finished Water Pump Addition
Process Mechanical	Sedimentation Basin Plate Settler Installation
Process Mechanical	New 2-MG Clearwell
Structural	TPS Access Modifications
Architectural	Laboratory Expansion
Architectural	New Maintenance Building

Section 4

Conclusions and Recommendations

Section 2 of the report presented the condition assessment findings for major equipment and systems at the Pee Dee Regional WTP. Section 3 presented the results of an evaluation focused on expanding the plant treatment capacity by up to 5 MGD by identification of replacement and/or expansion needs.

This Section of the report will help guide the City in prioritizing and planning capital improvement projects(s) by summarizing the conditions assessment results, expansion needs, recommendation of priority project(s), and an opinion of cost for the priority project(s).

4.1 Opinion of Probable Construction Cost

CDM Smith's Preliminary Opinion of Probable Construction Cost (OPCC) covers the projects identified in previous sections of this report. The OPCC estimates were developed in general accordance with guidelines established by the AACE (formerly Association for the Advancement of Cost Estimating International - AACEI) and is most accurately described as a Class 4 cost estimate. Class 4 cost estimates are appropriate for engineering designs between 1% and 15% complete, with expected variations ranging from -30% to +50%.

Table 4-1 summarizes the estimated cost for each project recommended in the Condition Assessment summary of the report (Section 2). The basic assumptions used during the cost calculations can be summarized as follows:

- Vendor quotes received for most equipment.
- Mechanical equipment installation cost is 25% of the equipment cost.
- Electrical work is approximately 25% of the direct cost excluding the cost of large concrete structures.
- Instrumentation work is approximately 10% of the direct cost excluding the cost of large concrete structures.
- Taxes are approximately 8% of the direct cost
- Subcontractor overhead/profit is approximately 25% of the electrical and instrumentation cost
- Bonds, permitting, insurance and mobilization are 8% of direct subtotal
- Field general conditions and contractor overhead/profit total is approximately 22%
- Construction contingency is 30%
- Note: Reduced contingency applied to selective projects noted in Table 4-1 below

Section 4 • Conclusions and Recommendations

- Design and Construction Engineering is 15%

It should be noted that each project OPCC should be escalated by 3% per year until the midpoint of project construction. This escalation has not been incorporated into the OPCC estimates in Table 4-1 and 4-2 below.

Table 4-1 Summary of Condition Assessment Priority Projects

Discipline	Project	Priority Level	Functional Category	OPCC
Process Mechanical	Caustic Room Rehabilitation	1	O	\$580,000.00
Building Mechanical	Operations Building Eyewash/Shower Replacement	1	N	\$80,000.00
Architectural	Operations Building Mezzanine Access and Fall Protection	1	N	\$90,000.00
Process Mechanical	Rehabilitation of Existing RWPS 1	2	O	\$180,000.00
Process Mechanical	Rehabilitation of Existing RWPS 2	2	O	\$260,000.00
Process Mechanical	Rehabilitation of Existing TPS	2	O	\$450,000.00
Process Mechanical	Rehabilitation of Existing FWPS	2	O	\$730,000.00
Process Mechanical	Replacement of Process Train Chain and Flights	2	O	\$1,650,000.00
Electrical	Generator Controls	2	M	\$20,000.00
Electrical	General Electrical Upgrades	2	M	\$40,000.00
Electrical	FWPS Replacement of VFDs	2	O	\$900,000.00
Electrical	RWPS 1 Replacement of VFDs	2	O	\$600,000.00
Electrical	RWPS 2 Replacement of VFDs	2	O	\$260,000.00
Electrical	TPS Replacement of VFDs	2	O	\$300,000.00
Process Mechanical	Replacement of Process Train Valves and Gates	3	O	\$1,880,000.00
Building Mechanical	Finished Water Pump Station HVAC Replacement	3	N	\$70,000.00
Building Mechanical	Operations Building HVAC Replacement	3	N	\$700,000.00
Building Mechanical	RWPS 1 HVAC Replacement	3	N	\$150,000.00
Building Mechanical	RWPS 2 HVAC Replacement	3	N	\$60,000.00
Instrumentation & Controls	UPS Room Housekeeping	3	M	\$30,000.00
Instrumentation & Controls	PLC-1 and PLC-4 OIT Replacement	3	N	\$30,000.00
Instrumentation & Controls	Turbidimeter Replacement	3	O	\$160,000.00
Instrumentation & Controls	Pressure Gauge Replacement	3	O	\$90,000.00
Architectural	RWPS 1 Roof Replacement*	3	N	\$290,000.00*
Architectural	RWPS 2 Roof Replacement*	3	N	\$120,000.00*
Architectural	FWPS Roof Replacement	3	N	\$320,000.00*
Architectural	Main Lab and BAC Lab Rehab	3	N	\$130,000.00
Architectural	Chemical Area CMU Repair	3	M	\$100,000.00
Architectural	Operations Building Roof Replacement	3	N	\$4,500,000.00*
Structural	Recoating of Chemical Areas	3	M	\$900,000.00*
Structural	Recoating of the Process Train	3	M	\$2,810,000.00*
Structural	RWPS 2 Canopy Recoating	3	M	\$70,000.00*
TOTAL				\$18,550,000.00

* Reduced contingency applied

Table 4-2 summarizes the estimated direct cost for each project recommended in the Expansion Plan section of the report (Section 3).

Table 4-2 Summary of Expansion Plan Projects

Discipline	Project	OPCC
Process Mechanical	RWPS 1 Raw Water Pump Addition	\$700,000.00
Process Mechanical	FWPS Finished Water Pump Addition	\$980,000.00
Process Mechanical	Sedimentation Basin Plate Settler Installation ¹	\$2,260,000.00
Process Mechanical	New 2-MG Clearwell	\$3,800,000.00
Building Mechanical	Operations Building HVAC Upgrades	\$140,000.00
Structural	TPS Access Modifications	\$290,000.00
Architectural	Laboratory Expansion	\$90,000.00
Architectural	New Maintenance Building	\$570,000.00
TOTAL		\$8,830,000.00

¹ Includes cost of plate settlers only, no other potential modifications

4.2 Recommendations

The Pee Dee Regional WTP has performed very well since its initial construction and startup nearly 20 years ago. Staff have maintained the equipment in a meticulous manner, maximizing useful life of equipment with minimal rehabilitation and replacement capital investment over the years. The focus of the study was to identify potential rehabilitation and replacement needs, and they are presented in Table 4-1.

The City must also balance the needs to rehabilitate the existing infrastructure with the needs to expand the Pee Dee WTP to meet future growth demands, as summarized in Table 4-2. The capital projects identified in the study total nearly \$27.4M, with approximately \$18.6M stemming from rehabilitation and/or replacement of existing equipment, facilities, and systems, and an investment of approximately \$8.8M to expand the plant to serve anticipated near-term demands.

The following bullets summarize the schedule for implementation of recommendations based on this study:

- Submit request for filter re-rating study by the Spring of 2021. Filter up-rating study requires 24/7 operation of the plant which can not start until FY 2022 (July 2021). The study will be 12 months in duration.
- Once the filter up-rating study is complete, the infrastructure and projects required to expand capacity by up to 5.0 MGD will be confirmed (i.e., as presented in Table 4-2 and/or other additional infrastructure required).
- The City will address rehabilitation and/or replacement needs as identified in Table 4-1 as capital and operations/maintenance budgets allow. Early projects targeted for completion with remaining FY21 budget potentially include addressing
 - Generator Controls, and
 - Selective Replacement of Process Train Slide Gates and Mud Valves

- Other priority projects the City has expressed interest in completing based on capital funding are:
 - Replacement of process train valves and gates
 - Recoating of treatment basins

The filter up-rating study must be completed prior to the Pee Dee Regional WTP approaching 80% treatment capacity. Several new developments are planned for the Pee Dee Regional WTP service area in the coming years. **Figure 4-1** presents the projected finished water demand through 2030 assuming similar growth (as compared to 2017-2019) for the existing service area, as well as new finished water demand from the following new users:

- Project Unknown: 1.0 MGD beginning April 2021
- Niagara Bottling Company: 1.0 MGD initial (July 2021), then 2.2 MGD (September 2023)
- Project Dark Star: 1.0 MGD beginning February 2022

When the plant begins 24/7 operation in July 2021, the City plans to increase its finished water production by 0.5 MG (and decrease its groundwater production correspondingly). Based on the finished water demands and schedule provided by the City the flow projections suggest the Pee Dee Regional WTP will reach 80% capacity in 2022.

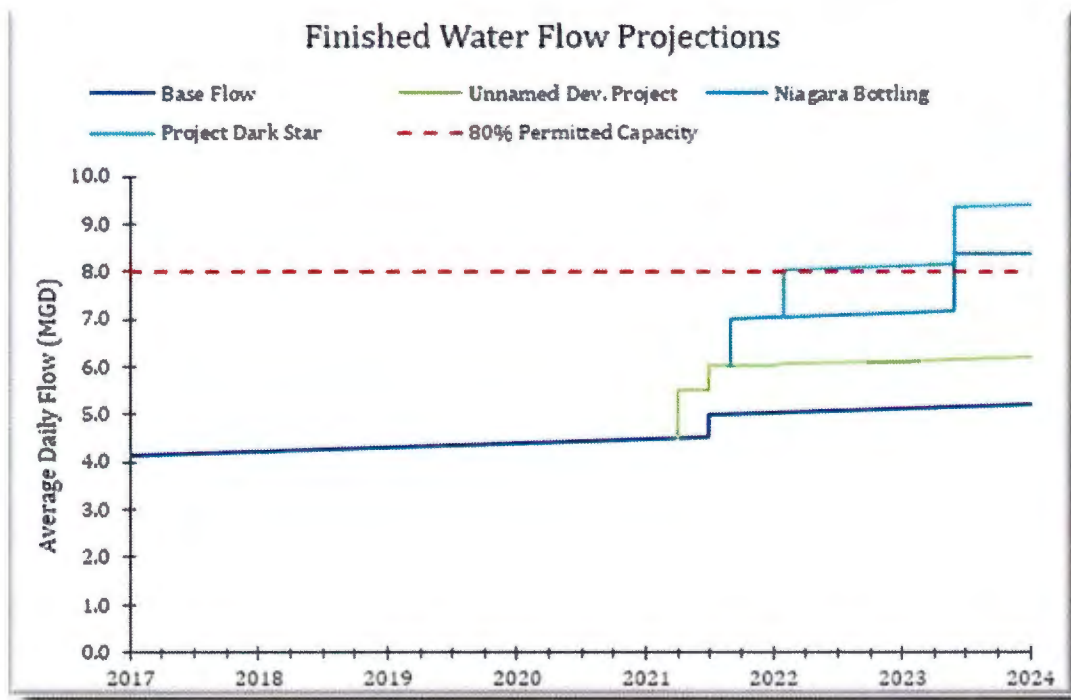

Figure 4-1
Pee Dee Regional WTP Finished Water Demand Projection

Appendix A

Design Life Table

This page intentionally left blank.

Purpose of this workbook:

This workbook provides a simple but structured way to calculate the remaining effective life of an asset. It is organized into 5 Steps, i.e. Load Data, Determine Modification Factors, Determine End of Asset Life, Determine Remaining Effective Life, and Validate and Record. The spreadsheet will automatically calculate the Remaining Effective Life and the Imminent Failure Mode based on the provided information. An override feature is also available to cancel the calculation whenever it is deemed incorrect.

How to use this Workbook:

Copy this workbook to your hard drive. Fill in basic asset information (Step 1) and the modification factors (Step 2). Estimate the time to failure due to Capacity, Level of Service and Financial Efficiency issues (Step 3). The spreadsheet will calculate the light yellow cells based on the inputted information. Any value inputted to the "Override Remaining Life" will be used as the final estimate. The reference for estimated design life is provided in the "Design Life Table" tab. Any adjustment/addition to the estimated design life should only be made in this tab.

Available Worksheets:

- Help** - Discusses and outlines the major components of this spreadsheet
- Calculation** - the main worksheet where all calculation of remaining effective life is conducted. Cells with a light yellow background indicate a calculated fields.
- Asset Count vs. PELC Chart** - this chart shows the distribution of asset by Percent Effective Live Consumed.
- Asset Condition vs. PELC Chart** - this chart shows the distribution of asset condition by Percent Effective Live Consumed.
- Design Life Table** - a summary of estimated design life compiled from many utility sources.
- Condition Score Description** - provides the description of asset physical condition, operational condition, reliability, availability, maintainability, and percent life consumed for each condition score

Definitions, operations:

- Refurb Year:** the year when the last refurbishment is conducted.
- Current Age (years):** Calculated by subtracting "Install Year" from "Current Year". The "Current Year" cell is located at the top of the Calculation table. If "Refurb Year" > "Install Year", then the current age is calculated by subtracting Refurb Year" from "Current Year".
- Condition Rating:** The current condition score of the asset in the scale of 1 (new) to 10 (fail).
- Estimated Design Service Life (years):** the expected life of an asset at the time of construction/acquisition, populated using information in the Design Life Table.
- Design Standard:** the standard used in the design process.
- Construction Quality:** the quality of construction used to build the asset.
- Material Quality:** the quality of material used to build the asset.
- Operational History:** the history of operational issues, maintenance and rehabilitation of the asset.
- Operating Environment:** the environmental condition in which the asset operates.
- External Stresses:** the external loading that may effects asset performance, especially for underground assets.
- Time to Capacity Failure (years):** the estimated time to asset failure due to Capacity issue.
- Time to Level of Service Failure (years):** the estimated time to asset failure due to Level of Service issue.
- Time to Efficiency Failure (years):** the estimated time to asset failure due to Business Efficiency issue.
- Time to Physical Failure (years):** the estimated time to asset failure due to Physical Mortality. It is calculated based on condition or age data.
- Imminent Failure mode:** the failure mode that is most likely to happen first, or, failure mode with the lowest time to failure estimate.
- Remaining Effective Life (years):** the lowest estimate of time to asset failure among the four possible failure modes.
- % Effective Life Consumed:** the ratio of current age over effective life, in percent.
- Override Remaining Life (years):** the estimated remaining life based on the direct observation by the utility's staff/expert. Whenever this cell has any value, it will override the current estimate of Remaining Effective Life.

This page intentionally left blank.

Asset Class	Design Life Standard Used	Utility 1	Utility 2	Utility 3	Utility 4	Utility 5	Utility 6	Utility 7
Actuator - Valve	25	25	25+	15	15	20	25	25
Air Handling Unit - Small wall mounted	25	30	25+	15	10	15+	15	25+
Air Handling Unit - Large (Supply, exhaust)	25	32	25+	20	20	25+	25+	25+
Analyzer	12	30	12	4	10	12		10
Auto Transfer Switch	25	N/A	25+	15	15	15		20
Barscreen - Bar and Rack	25	N/A	25+	20	25	25+	20	20
Blower / Compressor - Centrifugal	25	40	25+	15	25	25+	25+	NA
Blower / Compressor - Rotary Screw	25	30	25+	15	20	15	15	15+
Blower / Compressor - Rotary Vane	20	30	25+	15	N/A	15	15	20+
Boiler - Gas fired	27	N/A	25+	20	20	25+	25+	30
Boiler - Hot water	27	N/A	25+	20	25	25+	25+	NA
Boiler - Oil fired	27	N/A	25+	20	N/A	N/A	N/A	30
Burner - Waste gas	15	N/A	12	15	15	10	15	8+
Centrifuge	13	N/A	25+	10	N/A	N/A	N/A	NA
Chiller	25	25	25+	20	20	N/A	25+	15
Chlorinator	25	30	25+	15	N/A	20	25	15
Clutch - Electromagnetic/eddy current	27	30	25+	20	25	20	25	25+
Compressor - Reciprocating , Large Capacity	25	30	25+	15	15	20	15	25+
Compressor - Reciprocating, Methane gas	25	N/A	25+	15	20	20	N/A	15
Compressor - Reciprocating, All others	25	30	25+	15	20	20	15	NA
Controller	15	22	12	15	12	12		20+
Control Valve	25	25	25+	15	10	20	20	15
Conveyor	20	40	25+	25	30	30	N/A	20
Crane	30	40	25+	20	30	30+	25+	30+
Cyclone	20	N/A	25+	15	20	25+	25	15
Dryer - Air	25	20	25+	10	10	10	15	25
Ejector	20	N/A	25+	10	N/A	20	20	NA
Evaporator	20	30	25+	20	N/A	20	20	15
Feeder - Dry Chemical	15	30	10	10	N/A	N/A	N/A	10+
Filterpress	22	22	25+	N/A	25	20	N/A	20+
Fire alarm panel	12	N/A	12	10	10	N/A		15
Flow recorder	10	25	12	10	20	12		10+
Flowmeter - Magnetic	15	25	12	10	15	15		15
Flowmeter	12	25	12	10	15	15		12+
Gravity Belt Thickener	20	22	25+	N/A	N/A	20	N/A	20+

Asset Class	Design Life Standard Used	Utility 1	Utility 2	Utility 3	Utility 4	Utility 5	Utility 6	Utility 7
Gate - Slide	30	40	25+	25	20	20	25+	25
Gate - Sluice	30	40	25+	25	20	40	25+	25
Gear Reducer	25	35	25+	20	25	15	20	25
Generator - Co Generation	20	N/A	25+	10	30	N/A	N/A	NA
Generator - Standby, Diesel Engine	20	30	25+	10	30	20	N/A	20
Generator - Emergency Portable	20	30	25+	10	20	20	20	20
Grinder - Digested Sludge	17	25	25+	10	15	10	10	10
Grit Auger unit	20	N/A	25+	10	N/A	15	12	15
Grit Screening dewatering unit	20	N/A	25+	10	15	15	15	NA
Heat exchanger - air	15	N/A	N/A	15	15	15	20	NA
Heat exchanger - oil	15	N/A	N/A	15	20	20	20	NA
Heat exchanger - water	12	N/A	N/A	15	15	30	20	25
Hydraulic Lubrication system	25	N/A	25+	20	N/A	N/A	N/A	25
Hydraulic Operator	25	N/A	25+	20	20	20	20	25
Hydraulic Press	25	N/A	25+	20	N/A	25+	25+	25
Hydraulic System Skid	25	N/A	25+	20	20	25+	25+	25
Indicator - Flow level	12	N/A	12	10	10	12		10
Indicator - Pressure	12	N/A	12	10	10	10		10
Indicator - Temperature control	12	N/A	12	10	10	10		10+
Injector	15	N/A	12	12	N/A	15	15	10
Level control system	12	N/A	12	10	15	15		15
Mixer - Centrifugal	25	30	25+	20	25	15	20	25
Mixer - Static	25	40	25+	20	25	30	20	25
Motor - Greater than 5 HP	25	20	25+	20	15	20+		20+
Motor - Greater than 5 HP and low speed (500)	30	50	25+	20	15	20+		30
Motor Control Center	30	40	25+	15	20	20+		30
Odor Control unit	12	20	12	15	10	15	15	15+
Odor Reduction Tower	25	40	25+	5	15	N/A	10	NA
Panel - Bubbler	15	N/A	12	15	10	20		20
Panel - Lighting	25	30	25+	15	15	20		30
Panel - Local control	25	30	25+	15	20	20		25
Panel - Power distribution	25	30	25+	15	15	20		30
Panel - annunciator	15	N/A	25+	15	15	30		20+
Power Supply	20	30	12	12	15	20		15
Pressure vessel	25	N/A	25+	25	30	25+	25+	25

Asset Class	Design Life Standard Used	Utility 1	Utility 2	Utility 3	Utility 4	Utility 5	Utility 6	Utility 7
Programmable controller	15	20	12	7	10	10		10
Pump, centr. - Small circulating close coupled units	15	20		10	15	10	20	15
Pump, centr. - 60 MGD and above (Raw Sewage)	40	40	25+	20	25	40	25+	NA
Pump, centr. - Recessed Impeller type (WEMCO)	30	30	25+	N/A	25	25+	20	25+
Pumps - All others, centr.	27	30	25+	6		20	20	25
Pump - Chemical	10	40	12	10	10	15	15	10
Pump - Diaphragm	10	N/A	12	10	10	10	10	20
Pump - Hydraulic	20	40	25+	10	20	15	15	20
Pump - Lobe / Gear	15	N/A	25+	5	20	15	10	15
Pump - Metering	12	N/A	12	5	10	7	5	10+
Pump - Portable with trailer	15	N/A	12	10	N/A	25	25	20
Pump - Progressive Cavity	20	N/A	25+	10	10	15	12	20
Pump - Sump, 5 HP or Less	20	30	25+	5	20	5	10	10+
Pump - Sump, greater than 5HP	25	30	25+	10	20	20	15	25+
Pump - Vertical Turbine	25	30	25+	10	25	25+	15	25
RTU	10	N/A	12	7	8	12		10
Samplers	15	N/A	12	10	5	12		5+
SCADA	12	N/A	12	7	10	15		10
Scale - Truck	25	35	25+	N/A	25	20	N/A	NA
Scrubber systems	25	N/A	25+	15	20	15	7	25
Skimmer - Mechanical	20	N/A	25+	15	25	15		20+
Strainer - Water	25	30	25+	20	25	20	20	25
Switchgear	30	35	25+	20	20	25+		30
Tank - Chemical	25	30	25+	15	10	25+	15	25
Tank - collector drive unit	25	40	25+	20	25	20	25+	25+
Transformers	25	40	25+	15	20	25+		30
Transmitter - Flow level	12	N/A	12	12	5	10		10
Transmitter - Pressure	12	N/A	12	12	5	10		10
Turbidity meter	12	N/A	12	12	10	10		10
Uninterruptable Power Supply	12	20	12	12	10	12		15
Valves - 4" and smaller	25	25	25+	25	20	25+	25+	25
Valves - 4" and larger	20	25	25+	25	25	25+	25+	25
Variable Frequency Drive	12	20	12	20	10	12		12+
Vibration monitor	10	N/A	12	10	15	15	10	15

This page intentionally left blank.

Appendix B

Condition Assessment Spreadsheet

This page intentionally left blank.

Condition Assessment Summary

Priority Level Definitions

- Class 1** A condition in which failure of the system, equipment or building component is imminent, and its failure would directly and significantly impact operations at the WTP, including treatment capacity, water quality, or safety.
- Class 2** A condition in which failure of the system, equipment or building component is imminent, and failure would result in loss of back-up capacity, or cause further damage, but not impact operations in terms of treatment capacity, water quality, or safety.
- Class 3** A condition of failure or imminent failure of the system, equipment or building component that will not impair operations or safety but may lead to deterioration that would increase repair cost.
- Class 4** An improvement that has not been made that would result in protecting the status quo with regard to water quality, water production quantity or safety.
- Class 5** Any system, equipment or building component that should be corrected or improved, and in which the failure does not impact water quality, water production quantity or safety.

Category Definitions

- O** Operational Improvements - Capital improvement projects that directly impact production or water quality.
- N** Non-Operational Improvements - Capital improvement projects that do not directly impact production or water quality.
- M** Maintenance Improvements - Maintenance related improvements.

Discipline Codes

- | | |
|--------------------------|------------------------------|
| A Architectural | M Building Mechanical |
| E Electrical | P Process Mechanical |
| I Instrumentation | S Structural |

Notes

1. Expected Remaining Useful Service Life is based on a typical industry estimation of service life (refer to Appendix A for the values used) and/or engineering judgement. It is not necessarily indicative of the actual remaining service life.
2. Individual items presented in this spreadsheet may be grouped together in the report as a single construction package to assist the City with budget and schedule.
3. Refer to Condition Assessment Forms (Appendix C) for photos and comments

This page intentionally left blank.

MCC-2B	MCC-2B	18	Square D	Model 6	14540551-006	15-20 years			480V	1200
Main Switchgear Battery System		18	Hitran	SCR48-1-12	14327/419830-ZK	5 years			48VDC	12
MCC-1B	MCC-1B	18	Square D	Model 6	14540551-007	15-20 years			480V	1200
MCC-3A	MCC-3A	18	GE	E9000	0C60X0157L01	15-20 years			480V	800
MCC-3B	MCC-3B	18	GE	E9000	0C60X0157L02	15-20 years			480V	800
Emergency Shower/Eyewash (all)	ES/EW	19				5 years				
Feed Pump Nos. 1, 2, 3, & 4	CAUS # 1,2,3,4	19	Macroly	GD 6XNN8PM4NN	230889-13	0	104 gph	1750 rpm	180	3.7
Piping, Valves, and Appurtenances		19				6				
Transfer Pump Nos. 1 & 2		19	Walchem	MDH-F400FEG-D	110171374	1	35 gpm	3440 rpm	480	
		19								
VFD FWP-1	FWP-1	1	Rockwell	R2U5A04038-0001					480V	415
VFD FWP-2	FWP-2	18	Robicon							415
VFD FWP-3	FWP-3 VFD	18	Robicon							415
Generator		18	Cummins	1500DFLE-2596	C020346965-B				480V	1500K
VFD RWP-1	RWP-1 VFD	16	Robicon							
VFD RWP-2	RWP-2 VFD	16	Robicon							
VFD RWP-3	RWP-3 VFD	16	Robicon							
Reservoir Pump No. 1 VFD	Raw Water Pump 1	18	Cutler-Hammer	CP9000						
Reservoir Pump No. 2 VFD	Raw Water Pump 1	18	Cutler-Hammer	CP9000						
VFD TP-1	TP-1 VFD	18	Robicon							
VFD TP-2	TP-2 VFD	18	Robicon							
VFD TP-3	TP-3 VFD	18	Robicon							
High Service Pump Nos. 1, 2, & 3	FWP-1, -2, -3	19	Ingersoll-Dresser Pump	23EKM-5		6	3500gpm	900rpm	460	500
Pre-Lube Pump		19				6			480	20
Raw Water Pump No. 3	RWP-3	19	Ingersoll-Dresser Pump	22SNL-3	C89A12D140001	0	4000gpm	890rpm	460	350
Reservoir Pump Nos. 1 & 2		19	Fairbanks Morse	VTSH-AWF	901092-0	6	16500 gpm	591rpm	460	171
Sludge Collector Nos. 1, 2, & 3		19	USFilter	CSS Collector	18794-01	1			480	3
Transfer Pump Nos. 1 & 2	TP-1	19	Ingersoll-Dresser Pump	12MFC21A	E08 9111719-001 R-1	8		900rpm	460	200
Transfer Pump No. 3	TP-3	19	Ingersoll-Dresser Pump	12MFC21A	E08 9111721-001 R-2	8		900rpm	460	200
Caustic B-141										
Ferric B-142										
Fluoride B-143										
Sodium Hypo B-144										
Exterior										
Break Room										
Lab and Lab Storage										
Offices, Control, and Conference Rooms										
Roof										
Vestibules, Lobbies, and Corridor										
Exterior and Canopy										
Interior										
FIELD INSTRUMENTATION, CHEMICAL FACILITIES	Various	19	Various							
FIELD INSTRUMENTATION ANALYZERS AND GENERAL	Various	19	Various							
PLC-4	PLC-4	19	Siemens PLC	S7-400						
SCADA System		19	Dell Servers and other components							
PLC-1	PLC-1	19	Siemens PLC							
Air Cooled Condensing Unit	ACCU-3	18	Addison	RH-134E		0 years	13-tons		480 V/3Ø	
Air Handling Unit	AHU-3	19	Addison	HCH-134		0 years	13-tons		480 V/3Ø	
Air Handling Unit	AHU-8	5	Carrier			0 years	5-tons		480 V/3Ø	
Exhaust Fan	EF-19	19	Greenheck	CUBE-300-10-X		0-1 years	5,200 CFM		480 V/3Ø	
Exhaust Fan	EF-30	19	Greenheck	CUE-098-A-X		0-1 years	675 CFM		115 V/1Ø	
Exhaust Fan	EF-8	19	Greenheck	CUBE-101-3-X		0-1 years	1,000 CFM		115 V/1Ø	
Gas Boiler	BLR-1	19	Smith Cast Iron Boilers			0-1 years			115 V/Ø	
Gas Water Heater	GWH-1, -2	19	AO Smith			0-1 years			115 V/Ø	
Mud Valves, all	Various	19	Clow/M&H			6				
Slide gates, all	Various	19	HydroGate			6				
Generator/Electrical		19								
		19								
		19								
		19								
Storage Canopy		19								
Basin No. 1		19								
PLC-2	PLC-2, I-1, C-1	19	Siemens PLC							
Siemens S&S-300 CPU	PLC-1-6	19	Siemens	SIMATIC S7-300 and S7-400						
FILTER CONSOLES 1 - 6	FILTER CONSOLES 1 - 6	19	Revere Control System (PCSS)							
Exhaust Fan	EF-1	19	Greenheck	CUBE-400-30-X		0-1 years	13,000 CFM		480 V/3Ø	
Exhaust Fan	EF-2	19	Greenheck	CUBE-400-30-X		0-1 years	13,000 CFM		480 V/3Ø	
Air Cooled Condensing Unit	ACCU-6	19	Trane	TWP024C		0-1 years	2-tons		208 V/1Ø	
Air Cooled Condensing Unit	ACCU-7	19	Trane	TWP024C		0-1 years	2-tons		208 V/1Ø	
Air Cooled Condensing Unit	ACCU-8	19	Trane	TWY060B		0-1 years	5-tons		208 V/1Ø	
Air Cooled Condensing Unit	ACCU-10	19	Trane	TWY060B		0-1 years	5-tons		208 V/1Ø	
Air Cooled Condensing Unit	ACCU-9	19	Trane	TWY060B		0-1 years	5-tons		208 V/1Ø	
Air Handling Unit	AHU-10	19	Trane			0-1 years	5-tons		208 V/1Ø	
Air Handling Unit	AHU-6	19	Trane			0-1 years	2-tons		208 V/1Ø	
Air Handling Unit	AHU-7	19	Trane			0-1 years	2-tons		208 V/1Ø	
Air Handling Unit	AHU-9	19	Trane			0-1 years	5-tons		208 V/1Ø	
Duct Coil	DC-1	19	Heatcraft			0-1 years				
Duct Coil	DC-2	19	Heatcraft			0-1 years				
Duct Coil	DC-3	19	Heatcraft			0-1 years				
Duct Coil	DC-4	19	Heatcraft			0-1 years				
Duct Coil	DC-5	19	Heatcraft			0-1 years				

Exterior											
Lower Levels and Stair Well											
Upper Level – Pump Room											
Panel LP-2A	LP-2A	18	Square D	NQOD-E2	12145405510280001	20-25 years			208/120V	150.	
Panel LP-2B	LP-2B	18	Square D	NF	12145405510170001	20-25 years			480/277V	60.	
Panel PC/TC-3	PC/TC-3	18	Square D	NQOD		20-25 years			208/120V	60.	
Transformer TR-2A	TR-2A	18	Square D	30T3HBCU		20-25 years			480-208/120V		
Fire Alarm Control Panel		18	Silent Knight			5-10 years					
Security Alarm Panel		18	Simplex	4010		5-10 years					
Main Switchgear		18	Square D	Power-Zone 4	14540551-051	15-20 years			480V	3200.	
MCC-1A	MCC-1A	18	Square D	Model 6	14540551-008	15-20 years			480V	1200.	
Panel LP-1A	LP-1A	18	Square D	NQOD	12145405510300001	20-25 years			208/120V	400.	
Panel LP-1B	LP-1B	18	Square D	NQOD	12145405510340001	20-25 years			208/120V	100.	
Panel LP-1C	LP-1C-SUB	18	Square D	NQOD	12145405510330001	20-25 years			208/120V	150.	
Panel PC/TC-1A	PC/TC-1A	18	Square D	NQOD	12145405510220001	20-25 years			208/120V	60.	
Panel PP-4	PP-4	18	Square D	NF	12145405510160001	20-25 years			480/277V	100.	
Subpanel LP-1B	LP-1B SUB	18	Square D	NQOD	12145405511620001	20-25 years			208/120V	225.	
Subpanel LP-1C	LP-1C-SUB	18	Square D	NQOD	12145405511530001	20-25 years			208/120V	150.	
Subpanel PC/TC-1A	PC/TC-1A SUB	18	Square D	NQOD	12145405512370001	20-25 years			208/120V	60.	
Subpanel PP-4	PP-4 SUB	18	Square D	NF	12145405512060001	20-25 years			480/277V	100.	
Transformer TR-1A	TR-1A	18	Square D	112T3HBCU	14540551-046-01	20-25 years			480-208/120V		
Panel LP-1E	LP1E	18	Square D	NQOD	12145405510310001	20-25 years			208/120V	400.	
Panel LP-1F	LP1F	18	Square D	NQOD	12145405510320001	20-25 years			208/120V	125.	
Panel LP-1G	LP1G	18	Square D	NQOD	12145405510260001	20-25 years			208/120V	70.	
Panel PC/TC-2	PC/TC 2	18	Square D	NQOD	12145405510230001	20-25 years			208/120V	60.	
Panel PP-3	PP-3	18	Square D	I-Line	12145405510150001	20-25 years			480/277V	400.	
Subpanel LP-1E	LP-1E SUB	18	Square D	NQOD	12145405511480001	20-25 years			208/120V	400.	
Subpanel LP-1F	LP-1F SUB	18	Square D	NQOD	12145405511430001	20-25 years			208/120V	225.	
Transformer TR-1E	TR1E	18	Square D	112T3HBCU	1450551-046-02	20-25 years			480-208/120V		
UPS-Z	UPS-2	18	Liebert	16kVA, 53	U1AA016ADLFOX3Z	5-10 years			480V	23.	
Panel LP-1D	LP-1D	18	Square D	NQOD	12145405510290000	20-25 years			208/120	100.	
Panel PP-5	PP-5	18	Square D	NF	12145405510410000	20-25 years			480/277V	100.	
Transformer TR-1D	TR-1D	18	Square D	30T3HBCU		20-25 years			480-208/120V	30kV.	
Panel LP-UPS	LP-UPS	18	Square D	NQOD	12145405510250000	20-25 years			208/120V	50.	
UPS-1	UPS-1	18	Liebert	UP Station 53		0 years				136A (DC)	
Panel LP-1H	LP-1H	18	Square D	NQOD	12145405510270001	20-25 years			208/120V	150.	
Panel LP-1J	LP-1J	18	Square D	NF	1214540551850001	20-25 years			480/277V	100.	
Panel PP-1	PP-1	18	Square D	NF	12145405510190001	20-25 years			480/277V	225.	
Panel PP-2	PP-2	18				20-25 years					
Panel PP-UPS	PP-UPS	18	Square D	12145405510210001		20-25 years			480/277V	100.	
Subpanel LP-1J	LP-1J SUB	18	Square D	NF	12145405510180001	20-25 years			480/277V	100.	
Transformer TR-1H	TR-1H	18	Square D	45TQ36770	14540551-045	20-25 years			480-208/120V		
MCC-1 Generator									480V		
MCC-1 Utility Transformer									7-480/277V		
MCC-1	MCC-1	16	Square D	Model 6	14540551-007	15-20 years			480V	1600.	
MCC-1 ATS	Automatic Transfer Switch	16	Thompson		TS 893-1600A-480	15-20 years			480V	1600.	
Panel LP-3A	LP-3A	18	GE	AQF	AXF255B6L5	20-25 years			208/120V	225.	
Transformer TR-3	TR-3	18	GE	9T23Q9874G80	K 166341	20-25 years			480-208/120V		
PLC-5	PLC-5	19	Siemens PLC	57-300			See Siemens 57-300 assessment form.				
SCADA System		19	Dell Servers and other components								
Filter Consoles 1 - 6	PLC -3-1, PLC3-2, RIO 3-1, 3-2,	19	Siemens PLC								
PLC-6	PLC-6	19	Siemens PLC	57-300			See Siemens 57-300 assessment form.				
Air Cooled Condensing Unit	ACCU-1	2	Carrier	38AUDA12		10-15 years		10-tons	480 V/3Ø		
Air Cooled Condensing Unit	ACCU-2	2	Carrier	38AUDA12		10-15 years		10-tons	480 V/3Ø		
Air Handling Unit	AHU-1	2	Carrier	40RUA12		10-15 years		10-tons	480 V/3Ø		
Air Handling Unit	AHU-2	2	Carrier	40RUA12		10-15 years		10-tons	480 V/3Ø		
Electric Unit Heater	EUH-1	19	Indeeco	234-U11A-0390U		0-1 years		38.4 kW	480 V/3Ø		
Electric Unit Heater	EUH-2	19	Indeeco	234-U11A-0390U		0-1 years		38.4 kW	480 V/3Ø		
Air Cooled Condensing Unit	ACCU-4	2	Carrier	40RUA08		10-15 years		7.5-tons	480 V/3Ø		
Air Cooled Condensing Unit	ACCU-5	3	AAON	CFA-031-D-A-3		15 years		31-tons	480 V/3Ø		
Air Handling Unit	AHU-4	2	Carrier	40RUA08		10-15 years		7.5-tons	480 V/3Ø		
Air Handling Unit	AHU-5	3	AAON			15 years		31-tons	480 V/3Ø		
Exhaust Fan	EF-11	5	Greenheck	G-097-VG-4-X		10 years		700 CFM	115 V/1Ø		
Exhaust Fan	EF-12	5	Greenheck	G-097-VG-4-X		10 years		700 CFM	115 V/1Ø		
Exhaust Fan	EF-4	5	Greenheck	G-097-VG-4-X		10 years		400 CFM	115 V/1Ø		
Exhaust Fan	EF-5	5	Greenheck	G-097-VG-4-X		10 years		400 CFM	115 V/1Ø		
Gravity Hood	GH-2	19	Greenheck			1-2 years					
Gravity Hood	GH-3	19	Greenheck			1-2 years					
Roof Top Unit (Lab)	RTU-1	~5	AAON	RQ-006-3-J		10 years		6-tons	480 V/3Ø		
Air Cooled Condensing Unit	ACCU-11	2.5	Carrier	38AUDA12		10-15 years		10-tons	480 V/3Ø		
Air Cooled Condensing Unit	ACCU-12	2.5	Carrier	38AUDA12		10-15 years		10-tons	480 V/3Ø		
Air Handling Unit	AHU-11	2.5	Carrier	40RUA12		10-15 years		10-tons	480 V/3Ø		
Air Handling Unit	AHU-12	2.5	Carrier	40RUA12		10-15 years		10-tons	480 V/3Ø		
Electric Unit Heater	EUH-3	19	Indeeco	234-U11L-0200U		0-1 years		20 kW	480 V/3Ø		
Electric Unit Heater	EUH-4	19	Indeeco	234-U11L-0200U		0-1 years		20 kW	480 V/3Ø		
Electric Unit Heater	EUH-5	19	Indeeco	234-U11N-0100U		0-1 years		10 kW	480 V/3Ø		
Electric Unit Heater	EUH-6	19	Indeeco	234-U11N-0100U		0-1 years		10 kW	480 V/3Ø		
Electric Unit Heater	EUH-7	19	Indeeco	234-U11N-0100U		0-1 years		10 kW	480 V/3Ø		
Electric Unit Heater	EUH-8	19	Indeeco	234-U11N-0100U		0-1 years		10 kW	480 V/3Ø		
Chemical Sump Pump No. 7		19				0					
Chemical Sump Pump No. 5		19				0					
Chemical Sump Pump No. 2		16				0		600.		30.	

Condition Assessment Forms

This page intentionally left blank.

Appendix D

Plant Expansion to 15 MGD and Review of State Regulatory Requirements Technical Memorandum

This page intentionally left blank.



Memorandum

To: Mr. Michael Hemingway

From: Chris Kolkhorst, P.E.

Date: September 24, 2020

Subject: Pee Dee River Regional Water Treatment Plant
Plant Expansion to 15 MGD and Review of State Regulatory Requirements

Project Background

The Pee Dee River Regional Water Treatment Plant (WTP) is a conventional surface water treatment plant owned and operated by the City of Florence, South Carolina (the City). The plant began operation in 2002 with a permitted capacity of 10 million gallons per day (MGD). Since its initial construction, the plant has not had any facility expansions or major equipment upgrades. With few exceptions, all plant buildings, infrastructure, and equipment are approaching 20 years of service.

The City desires to evaluate, design, and construct improvements to the WTP, including replacement of aging equipment and systems, and to expand the WTP to a permitted peak production capacity of 15 MGD. CDM Smith has been tasked with conducting a condition assessment of major equipment and systems at the WTP and evaluating facility replacement and/or expansion options to add the additional 5 MGD to the permitted capacity.

The objective of this memorandum is to present the existing plant process design criteria and equipment capacities, identify equipment capacity requirements to meet a flow of 15 MGD, and provide any pertinent regulatory context.

Main Process Train

Table 1 presents the key design parameters of the main process train at the current permitted capacity of 10 MGD, at the proposed permitted capacity of 15 MGD, and at the proposed permitted capacity of 15 MGD with plate settlers installed in the sedimentation basins. Values in red text with light red highlight indicate a failure to meet the established state criterion.

Table 1 Design Parameters of Main Plant Processes

Parameter	State Requirement	10 MGD	15 MGD	15 MGD w/ Plates	units
1. Rapid Mix					
Min. Detention Time	None	30	20	20	sec.
2. Flocculation					
* Velocity, through basin	0.5 - 1.5	1.99	2.99	2.99	fpm
* Velocity, through effluent pipe	0.5 - 1.5	0.18	0.28	0.28	fps
* Velocity, through effluent channel	0.5 - 1.5	0.18	0.28	0.28	fps
Min. Detention Time	30	30.1	20.1	20.1	min.
Velocity Gradient, G	5 - 100	80	80	80	sec. ⁻¹
3. Sedimentation Basin					
Min. Detention Time	4	4.0	2.8	N/A	hrs.
* Max. Velocity, through basin	0.5	0.68	0.97	N/A	fpm
a. Plate Settlers					
† Max. Loading Rate	0.5	N/A	N/A	0.30	gpm/sf
4. Filters					
‡ Max. Loading Rate	4.0	3.87	5.80	5.80	gpm/sf
Max. Velocity, through influent channel	2.0	1.19	1.79	1.79	fps
Max. Velocity, through influent pipe	2.0	0.99	1.48	1.48	fps

* Exception letter obtained from DHEC during initial design of plant for these design parameters.

† The 0.30 gpm/sf plate loading rate is an example of a potential design loading rate that would meet State requirements.

‡ The City plans to perform a filter uprating study, per DHEC guidelines, to obtain approval for a max. loading rate of 6.0 gpm/sf

In order to expand the plant to a permitted capacity of 15 MGD, exceptions from DHEC will be required in addition to the already anticipated filter uprating. During the initial plant design, DHEC waived the flow-through velocity requirements for flocculation and sedimentation.

Pump Stations

Table 2 presents the existing required and actual firm pumping capacities of each existing pump station at the permitted capacity of 10 MGD and at the proposed capacity of 15 MGD. Firm capacity is defined as the throughput of all pumping units minus one. The Raw Water Pump Station, Reservoir Pump Station (also known as Raw Water Pump Station 2), and Finished Water Pump Station all have slots (space) reserved for an additional pump. Where a pump station's actual firm capacity fails to meet the required firm capacity at 15 MGD, the 15 MGD (PS Upgraded) column represents the capacities under a future condition where the vacant slots are filled by a pump that has capacity identical to the existing pumps. The Transfer Pump Station does not have a space reserved for a future pump. For this pump station, the stated actual capacity under the 15 MGD (PS Upgraded) column reflects the replacement of the existing pumps with new pumps of greater

capacity. Values in red text with light red highlight indicate that the actual firm capacity is not sufficient to meet the required firm capacity.

Table 2 Design Parameters of Pump Stations

Parameter	10 MGD	15 MGD (Existing PS)	15 MGD (PS Upgraded)	units
1. Raw Water Pump Station				
Firm Capacity Required	10.9	16.3	16.3	MGD
Firm Capacity Actual	13.9	13.9	17.3	MGD
2. Reservoir Pump Station				
Firm Capacity Required	10.9	16.3	16.3	MGD
Firm Capacity Actual	18.7	18.7	18.7	MGD
3. Transfer Pump Station				
Firm Capacity Required	10.9	16.3	16.3	MGD
Firm Capacity Actual	15.5	15.5	16.5	MGD
4. Finished Water Pump Station				
Firm Capacity Required	10.0	15	15	MGD
Firm Capacity Actual	10.8	10.8	15.12	MGD

Chemical Storage

Table 3 presents the days of chemical storage provided by the existing bulk tanks at the permitted capacity of 10 MGD and at the proposed permitted capacity of 15 MGD at the average chemical dose and average plant flow. Values in red text with light red highlight indicate a failure to meet the established state criterion.

Table 3 Days of Bulk Storage at Average Dose and Average Flow

Chemical	State Requirement	10 MGD	15 MGD	units
a. Sodium Hypochlorite	30	82	55	days
b. Coagulant (Ferric)	30	36	24	days
c. Caustic	30	40	28	days
d. Lime	30	77	52	days
e. Fluoride	30	565	390	days
f. Polymer	30	75	50	days

Table 4 presents the days of chemical storage provided by the existing day tanks at the permitted capacity of 10 MGD and at the proposed permitted capacity of 15 MGD at the average chemical dose and average plant flow. The WTP does not have day tanks for its lime or polymer feed systems. There are no identified storage deficiencies for the day tanks. The State does not have any stated requirements for day tanks.

Table 4 Days of Day Tank Storage at Average Dose and Average Flow

Chemical	10 MGD	15 MGD	units
a. Sodium Hypochlorite	5	4	days
b. Coagulant (Ferric)	2	1	days
c. Caustic	3	2	days
d. Lime	N/A	N/A	days
e. Fluoride	9	6	days
f. Polymer	N/A	N/A	days

Chemical Metering Pumps

Table 5 presents the existing chemical metering pump flow capacities and the required capacities to meet dosing requirements at the permitted plant capacity of 10 MGD and at the proposed permitted plant capacity of 15 MGD at the maximum chemical dose and maximum plant flow. The quantity (Qty.) column reflects the total number of pumps minus one, to allow for one standby pump for each chemical. Sodium hypochlorite and caustic each have two feed points, so the total number of pumps was divided by two before then subtracting one. There are no identified capacity deficiencies for the existing chemical metering pumps.

Table 5 Existing and Required Chemical Metering Pump Capacities at Maximum Dose and Maximum Flow

Chemical	Existing Pump Capacity			Capacity Required			
	Qty.	Capacity, each (gph)	Capacity, total (gph)	At 10 MGD (gph)	% Total Capacity	At 15 MGD (gph)	% Total Capacity
a. Sodium Hypochlorite (Pre-Disinfection)	1	104	104	35	34%	53	51%
b. Sodium Hypochlorite (Post-Disinfection)	1	104	104	35	34%	53	51%
c. Coagulant (Ferric)	3	104	312	107	34%	160	51%
d. Caustic (Pre-pH Adjust)	1	104	104	48	46%	72	69%
e. Caustic (Post-pH Adjust)	1	104	104	8	8%	12	12%
f. Lime	4	500	2,000	843	42%	1,265	63%
g. Fluoride	2	10	20	2	10%	3	15%
h. Polymer	2	147	294	34	12%	51	17%

cc:

Robbie Mott, City of Florence
 George Simon, CDM Smith

Appendix E

SC DHEC Operating Requirements and Filter Uprating Meeting Minutes

This page intentionally left blank. This page intentionally left blank.

SC DHEC Operating Requirements & Filter Upgrading Meeting

Minutes

Date:	October 16, 2020
Time:	11:00 AM
Location:	Pee Dee River Regional WTP – Education Center 2598 Florence Harlee Blvd, Florence, SC 29506
Project Name:	Pee Dee River Regional WTP Condition Assessment and Expansion
Project Location:	City of Florence, South Carolina

Attendees: Robbie Mott (City of Florence)
Michael Hemingway (City of Florence)
Richard Welch (SC DHEC – Columbia)
Kevin King (SC DHEC – Columbia)
Paula Brown (SC DHEC – Florence)
Karen Garris (SC DHEC – Florence)
Taylor Poston (SC DHEC – Florence)
Chris Kolkhorst (CDM Smith)
George Simon (CDM Smith – by phone)
Anish Luthra (CDM Smith – by phone)
Morgan Leger (CDM Smith)

Action items are in **bold** type.

Meeting Summary:

1. Chris Kolkhorst presented tables displaying calculations for the main process train, firm pumping capacity, chemical feed and storage, and finished water volumes at 10 MGD and 15 MGD as compared to the State requirements (see additional discussion items below).
2. He noted that DHEC previously allowed an exception for the flocculation basin flow-through velocities for the original plant operations in 2002. Calculations show that at 15 MGD, the flocculation detention time would be reduced from the required 30 minutes to 20 minutes. Mr. Kolkhorst also noted that advanced clarification technology (e.g., plate settlers, Superpulsators) would likely be necessary to meet clarification detention time requirements. A demonstration study for high-rate filtration (i.e., increasing from the current 4 gpm/sf loading rate to a 6 gpm/sf loading rate) performed in accordance with

DHEC guidelines would also need to be conducted and approved to operate at 15 MGD. DHEC did not foresee an issue with the reduced flocculation time.

3. Richard Welch stated that when a water treatment plant (WTP) has reached 80% of its design capacity (monthly average), DHEC typically requires the submission of a preliminary engineering report (preliminary design) and that DHEC requires that a high-rate filtration study to be performed prior to reaching or approaching that 80% capacity. DHEC will require 24-hour operation of the plant and the duration of the study is 12 months.
4. Michael Hemingway commented that, in addition to the upcoming bottling plant demand, there are potential economic development projects coming to the City that would increase water demand rapidly and atypically in contrast to population growth demands which occur more slowly. The City may also enter into an agreement with the Darlington County Water and Sewer Authority to provide supplementary water to their system. The City did not anticipate needing to transition to 24-hour operation of the plant to support bottling plant's initial 1 MGD start-up phase, but is considering returning to 24-hour operation in mid-2021 to support future projected demands and the commencement of a filter uprating study for a planned 5-mgd capacity expansion.
5. Chris presented a table displaying information on the existing pumps and future pump requirements at 10 MGD and 15 MGD. He discussed installing pumps into "future slots" to obtain firm capacity in the raw water pump stations and finished water pump stations. He acknowledged that the transfer pump station is currently equipped with dry-pit solids handling pumps and complete replacement with higher capacity pumps will be required to meet a 15 MGD firm capacity. The pump manufacturer has not pursued NSF 61 *certification* for their pumps, but the pumps are NSF 61 *compliant*. Changing pump type and manufacturer to achieve NSF *certification* will require extensive structural and mechanical modifications to the pump station in a very congested area with limited access.
6. Richard commented that DHEC had not seen this issue come up yet and therefore does not have a precedent established, but does not foresee this to be an issue. Richard asked for additional information clarifying the difference between NSF certified and NSF compliant.
7. George Simon responded that all pump metals and coating are NSF approved making them *compliant*. *Certification* requires a third-party reviewer to inspect materials and perform a leaching test on the pump. George added that for the Mills River WTP in Asheville, NC (which is nearly identical in design to the Pee Dee River Regional WTP), the North Carolina DEQ accepted pump NSF compliance. A copy of email correspondence between CDM Smith and NC DEQ regarding acceptability of NSF-*compliant* transfer pumps at the Mills River WTP is attached.
8. Chris presented another table displaying information on the existing and required bulk and day tank storage capacities at 10 MGD and 15 MGD. He affirmed that the existing bulk and day tanks meet requirements at 15 MGD, with the exception of the ferric chloride (coagulant) and sodium hydroxide (caustic) bulk storage tanks, which only provide a 24-day and 28-day supply, respectively.

9. Richard stated that due to the WTP's proximity to I-95 and ease of chemical acquisition, DHEC would not likely take issue with the existing tank volumes upon expansion to 15 MGD. He expressed, however, that Florence is in a "hurricane-prone" area and this may affect a formal decision.
10. Chris presented tables displaying day-tank chemical storage volumes and metering pump capacities. He confirmed there are no issues with the tanks or the ability to feed chemicals at an expanded 15 MGD capacity. In fact, the metering pumps will operate more optimally in the desired 40%-70% of capacity range, eliminating typical issues with metering pump "turn-down" at the low end of their range.
11. Chris discussed adding a redundant 2 MG pre-stressed concrete ground storage tank, acknowledging that while the capacity of plant will only be increasing by 50%, finished water storage will be increased by 100%, which will augment operational flexibility while still maintaining required CT volumes for disinfection.
12. Chris suggested putting together a combined schedule for a proposed filter uprating study, the anticipated design and construction durations for a 5-MGD expansion, and project Florence water demands for DHEC to evaluate. **The schedule will be sent to DHEC when the high-rate filtration study approach is submitted.**
13. George questioned what the duration and conditions of the filter uprating study need to be. DHEC stated that they can provide that information and a guidance document is available online.
 - a. Note, the referenced document can be found at the following link:
<https://scdhec.gov/sites/default/files/docs/Environment/docs/gdhrfs.pdf>
14. Michael and Robbie Mott discussed plant operating hours. Michael mentioned that transitioning to 24-hour operation will require additional operators, and that they can be added to the budget for the next fiscal year (which starts July of 2021). The current 16-hour operating schedule is a result of water demand, not funding.

This page intentionally left blank.

Appendix F

Selective Equipment Replacement Schedules

This page intentionally left blank.

Selective Slide Gate Replacement Schedule		
Size	Location	Quantity
42x48	Filter Influent Channel	1
30x30	Flocculator Basin Influent Channel	2
30x48	Flocculator Influent Channel	1
48x48	Rapid Mix Effluent Channel	2
16x16	Sedimentation Basin Effluent	3
30x36	Sedimentation Basin Effluent Channel	6
42x42	Sedimentation Basin Influent	6
12x12	Sedimentation Basin Influent	3
84x72	Sedimentation Influent Channel	2
24x48	Settled Water Channel	1
30x42	Settled Water Channel	2

Selective Mud Valve Replacement Schedule		
Size	Location	Quantity
4	RM Basin	2
4	Flocculator Influent Channel	2
4	Filter Influent Channel	2
24	Influent	2
12	Flocculator Basins	2
12	Sed Basins	3

Selective HVAC Replacement Schedule ¹		
Equipment Tag	Location	Quantity
EF-1	FWPS	1
EF-2	FWPS	1
EUH-1	FWPS	1
EUH-2	FWPS	1
GH-2	Operations Building - AHU	1
EF-20	Operations Building - Ammonia Room	1
HWUH-12	Operations Building - Ammonia Room	1
FTR-3	Operations Building - BAC Lab	1
EF-9	Operations Building - BAC Lab, Hood	1
BLR-1	Operations Building - Boiler Room	1
EF-16	Operations Building - Boiler Room	1
GWH-1, -2	Operations Building - Boiler Room	1
HWUH-6	Operations Building - Boiler Room	1
EF-10	Operations Building - Break Room	1
HWUH-7	Operations Building - Caustic Room	1
EF-18	Operations Building - Chemical Storage	1
EF-21	Operations Building - Chemical Storage	1
EF-24	Operations Building - Chemical Storage	1
HWUH-16	Operations Building - Chemical Storage	1
HWUH-18	Operations Building - Chemical Storage	1
HWUH-9	Operations Building - Chemical Storage	1
EF-15	Operations Building - Conference Room	1
FTR-7	Operations Building - Conference Room	1
FTR-8	Operations Building - Conference Room	1
AHU-6	Operations Building - Control Room	1
FTR-6	Operations Building - Control Room	1
EF-30	Operations Building - Corridor	1
HWUH-17	Operations Building - Corridor	1
EF-17	Operations Building - Cuastic Room	1
AHU-4	Operations Building - Education Center	1
DC-2	Operations Building - Education Center	1
FTR-1	Operations Building - Education Center	1
GH-3	Operations Building - Education Center	1
AHU-10	Operations Building - Electrical Room	1
AHU-9	Operations Building - Electrical Room	1
HWUH-11	Operations Building - Ferric Area	1
EF-19	Operations Building - Fluoride Room	1
HWUH-8	Operations Building - Fluoride Room	1
HWUH-15	Operations Building - Generator B-151	1
EF-26	Operations Building - Generator Room	1
SF-1	Operations Building - Lab	1
SF-2	Operations Building - Lab	1
EF-6	Operations Building - Lab Storage	1
EF-8	Operations Building - Lab, Fume Hood	1

Selective HVAC Replacement Schedule ¹		
Equipment Tag	Location	Quantity
FTR-2	Operations Building - Laboratory	1
EF-22	Operations Building - Lime Room	1
HWUH-13	Operations Building - Lime Room	1
ACCU-3	Operations Building - North Wall	1
ACCU-6	Operations Building - North Wall	1
ACCU-7	Operations Building - North Wall	1
FTR-4	Operations Building - Office B-117	1
FTR-5	Operations Building - Office B-118	1
AHU-5	Operations Building - Operations Area	1
DC-3	Operations Building - Operations Area	1
HWUH-10	Operations Building - Permanganate Area	1
AHU-3	Operations Building - Pipe Gallery	1
DC-1	Operations Building - Pipe Gallery	1
HWUH-19	Operations Building - Polymer Area	1
EF-13	Operations Building - Receiving	1
HWUH-5	Operations Building - Receiving	1
AHU-7	Operations Building - Shop	1
DC-4	Operations Building - Shop	1
EF-29	Operations Building - Shop	1
AHU-8	Operations Building - Sodium Hypochlorite Room	1
DC-5	Operations Building - Sodium Hypochlorite Room	1
EF-23	Operations Building - Sodium Hypochlorite Room	1
EF-3	Operations Building - Stair No. 1	1
HWUH-1	Operations Building - Stair No. 1	1
HWUH-3	Operations Building - Stair No. 1	1
EF-14	Operations Building - Stair No. 2	1
HWUH-2	Operations Building - Stair No. 2	1
HWUH-4	Operations Building - Stair No. 2	1
ACCU-10	Operations Building - West Wall	1
ACCU-8	Operations Building - West Wall	1
ACCU-9	Operations Building - West Wall	1
EF-25	RWPS 1	1
EF-27	RWPS 1	1
EF-28	RWPS 1	1
EUH-3	RWPS 1	1
EUH-4	RWPS 1	1
EUH-5	RWPS 1	1
EUH-6	RWPS 1	1
EUH-7	RWPS 1	1
EUH-8	RWPS 1	1
SF-3	RWPS 1	1
ACCU-1	RWPS 2	1
ACCU-2	RWPS 2	1
AHU-1	RWPS 2	1

Selective HVAC Replacement Schedule ¹		
Equipment Tag	Location	Quantity
AHU-2	RWPS 2	1

Note:

1. Refer to Appendix C - Condition Assessment Forms equipment properties (manufacturer, capacity, etc.) and condition rating.





First Tryon Advisors

SIMPLIFYING PUBLIC FINANCE

Utility Plan of Finance Discussion

City of Florence, South Carolina

Agenda

- 3 Financing Plan Overview
- 8 Timetable
- 10 Supporting Schedules and Information



Walter Goldsmith
President & COO

e wgoldsmith@firsttryon.com
t 704.926.2453
m 980.982.8583



Amy Vitner
Managing Director

e avitner@firsttryon.com
t 704.926.2457
m 980.294.1032

Financing Plan Overview

Situation Summary

Can growing needs be accommodated under existing rate structure?

- In 2023, the City issued \$33,500,000 to fund a portion of the \$537,500,000 water and sewer 10-year Capital Improvement Plan (CIP)
- Also in 2023, the City adopted the following annual rate increases to accommodate the CIP

Fiscal Year	Water	Sewer
2024	5.0%	5.0%
2025	10.0%	10.0%
2026	9.5%	9.5%
2027	9.5%	9.5%
2028	9.5%	9.5%
2029	2.0%	3.0%
2030	2.0%	3.0%

- Since 2023, the City’s project costs have grown to \$676,231,000, reflecting increased cost estimates as well as additional identified projects (see next page for detail increases)
- The City has asked if the previously adopted rates increases will be adequate to support the additional CIP costs
 - City’s rate consultant, Willdan, is updating their financial analysis, but early indication is yes– in the short term
 - City may need to consider additional rate increases once timing is determined for longer term projects
 - Analysis will be highly dependent on City’s FY2024 operating results

Phase II: Project Cost Detail

Project costs have increased significantly since 2023

- Project costs for Phase II have increased by \$77 million
- Total cost of Phase II is now \$305 million:
 - The City anticipates \$15 million of grant funding
 - The City has been approved for a \$24 million SRF Loan
 - The balance of \$266 million is expected to be financed with a revenue bond
 - First Tryon recommends Council approve a not to exceed borrowing amount of \$270 million
 - First Tryon recommends not issuing debt for the PFAS projects until timing is better understood

Projects	2023	2024	Change	Other Sources	2024 Revenue Bond Authorization
Surface Water Treatment Plant Expansion	143,000,000	210,000,000	67,000,000	15,000,000	195,000,000
Jeffries Creek Sewer Interceptor Phase I	45,000,000	45,000,000	-	24,000,000	21,000,000
PFAS	40,000,000	50,000,000	10,000,000	-	50,000,000
Total	228,000,000	305,000,000	77,000,000	39,000,000	266,000,000

- In addition to the Phase II costs increases above, the Wastewater Management Facility Expansion project has grown from \$180 million to \$250 million
 - Debt for this project is not anticipated to be issued until FY 2029
 - This is outside our 5-year projection period, but still important to continue to build revenues to be able to afford this future project

Projected Debt Service Requirements

Debt service remains in line with last year until 2030

- The red line represents projected annual debt payments based on the 2023 project cost estimates
- Starting in 2030, when the debt payments for the Wastewater Management Expansion commence, the City will likely need to identify additional revenues.

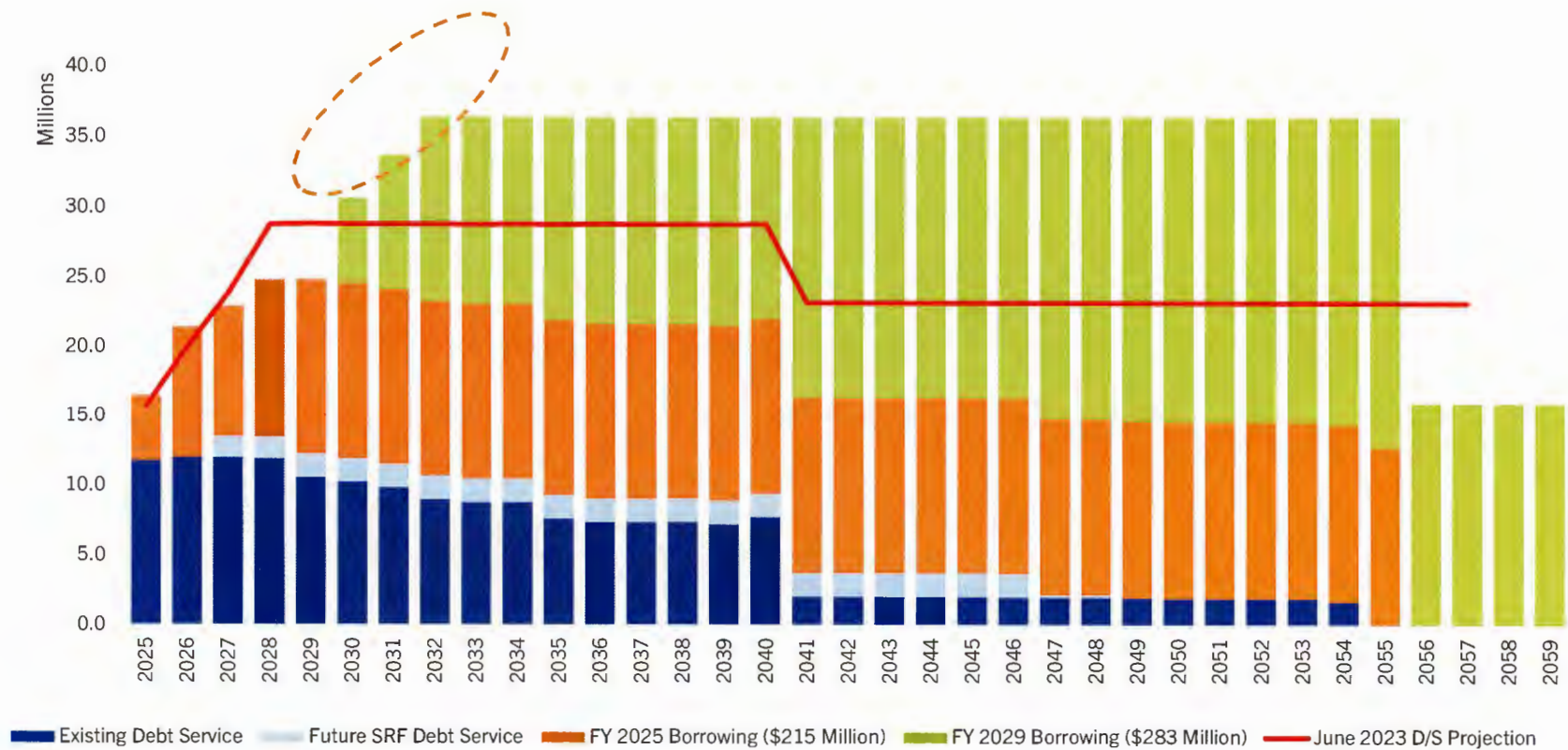

Timetable

Financing Calendar

Bonds sold in October 2024

Date	Task
August 12	City Council Meeting – First Reading
August/Sept	Documentation/Feasibility Review
September 9	City Council Meeting – Second Reading
September 16	Calls with Rating Agencies
October 9	Bond Pricing
October 30	Close Bond Issue

Supporting Schedules and Information

Capital Improvement Plan

As of June 2023

- Identified projects totaling \$537.5 million

- The Plan of Finance included three planned financings:
 - \$33.5 Million in Fall 2023 (FY 2024)
 - \$183 Million in FY 2025
 - \$230 Million in FY 2027

- The FY 2024 financing was completed in September 2023.
 - \$32.1 million of Revenue Bonds funded the \$33.5 million of projects described to the right.

- In addition, \$91 million of projects were considered to be funded through a combination of SCRIA, SRF, EDA, and Cash.

First Bond for Summer/Fall 2023 for Current Major Projects	
Project	Amount
Surface Water Treatment Plant Expansion (Planning/Design)	7,000,000
AESC Economic Development Project	18,000,000
Utility System Engineering Master Planning	4,000,000
Automated Water Meters for Billing	4,500,000
Total	33,500,000

Second Bond for Future Major Projects	
Project	Amount
Surface Water Treatment Plant Expansion (Construction)	143,000,000
PFAS (TBD)	40,000,000
Total	183,000,000

Third Bond for Future Major Projects	
Project	Amount
Wastewater Management Facility Expansion	180,000,000
Florence East Industrial Park (East Palmetto Sewer)*	50,000,000
Total	230,000,000

*Economic Development Related

Other Future Projects (SCRIA, SRF, EDA, Cash)	
Project	Amount
Jeffries Creek Sewer Interceptor Phase I	45,000,000
Timmonsville Pump Station & Force Main	25,000,000
Pye Branch Sewer Interceptor	5,000,000
Middle Swamp Sewer Interceptor	5,000,000
Woody Jones Sewer Interceptor	5,000,000
Police Cabin Lift Station Upgrade	6,000,000
Total	91,000,000

Projected Debt Service Requirements

As of June 2023

- The estimated maximum annual debt service associated with the June 2023 Plan of Finance was approximately **\$29 million**.

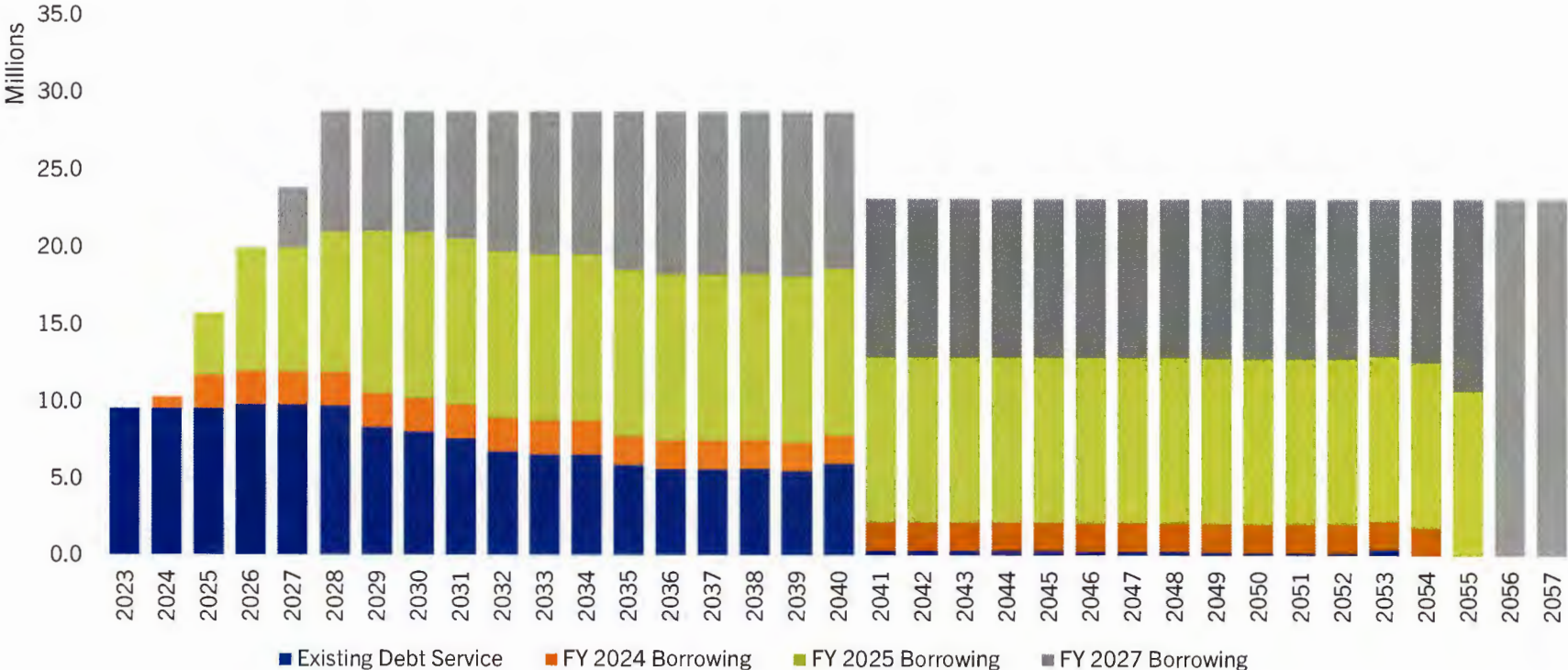

Forecasted Debt Service Coverage and Days Cash on Hand

As of June 2023

Description	2024	2025	2026	2027	2028	2029	2030
Revenues	\$50,975	\$56,715	\$65,470	\$72,151	\$79,595	\$82,247	\$85,728
Operating Expenses	25,429	26,700	28,035	29,437	30,909	32,454	34,077
Net Revenues Available for Debt Service	\$25,546	\$30,015	\$37,435	\$42,714	\$48,686	\$49,793	\$51,651
<u>Debt Service</u>							
Parity Debt	\$10,101	\$15,536	\$19,786	\$23,664	\$28,589	\$28,538	\$28,496
Subordinated Debt	605	605	605	605	605	605	605
Total Debt Service	\$10,706	\$16,141	\$20,391	\$24,268	\$29,193	\$29,143	\$29,101
Net Revenues After Debt Service	\$14,841	\$13,874	\$17,044	\$18,446	\$19,493	\$20,647	\$22,541
Capital Outlay	(5,631)	(3,237)	(1,757)	(51,257)	(1,257)	(1,257)	(1,257)
Revenues Over Expenditures	\$9,210	\$10,637	\$15,287	(\$32,811)	\$18,236	\$19,390	\$21,284
Ending Fund Balance	\$51,895	\$62,532	\$77,819	\$45,008	\$63,244	\$82,634	\$103,918
<u>Debt Service Coverage</u>							
Parity Debt	2.53	1.93	1.89	1.81	1.70	1.74	1.81
Total Debt	2.39	1.86	1.84	1.76	1.67	1.71	1.77
Days Cash on Hand	745 Days	855 Days	1,013 Days	558 Days	747 Days	929 Days	1,113 Days

Note: Dollar amounts in \$000s

Capital Improvement Plan

As of July 2024

Description	Fiscal Year Schedule	Total Capital Costs	FY 2025	FY 2026	FY 2027	FY 2028	FY 2029	FY 2030	FY 2031	FY 2032	FY 2033	FY 2034
WATER PROJECTS:												
Altitude Valves	FY 26	\$ 400,000	\$ -	\$ 400,000	\$ -	\$ -	\$ -	\$ -	\$ -	\$ -	\$ -	\$ -
Distribution System - Westward Growth	FY 32 - FY 40	8,331,000	-	-	-	-	-	-	-	2,777,000	2,777,000	2,777,000
Freedom Blvd	FY 27 - FY 31	10,000,000	-	-	2,000,000	2,000,000	2,000,000	2,000,000	2,000,000	-	-	-
SCADA - Distribution System	FY 25 - FY 27	2,000,000	500,000	500,000	1,000,000	-	-	-	-	-	-	-
Distribution System	FY 35 - FY 40	-	-	-	-	-	-	-	-	-	-	-
Florence East Industrial Park Elevated Water Tank	FY 26	7,000,000	-	3,500,000	3,500,000	-	-	-	-	-	-	-
Surface Water Treatment Plant	FY 24 - FY 27	210,000,000	40,000,000	45,000,000	45,000,000	45,000,000	35,000,000	-	-	-	-	-
PFAS	FY 28 - FY 29	50,000,000	-	-	-	25,000,000	25,000,000	-	-	-	-	-
AMI	Funded From 2023 Bonds	-	-	-	-	-	-	-	-	-	-	-
Distribution System 6" water main upgrades	FY 25 - FY 30	9,000,000	1,500,000	1,500,000	1,500,000	1,500,000	1,500,000	1,500,000	-	-	-	-
Groundwater Treatment Plant Rehabilitation & Maintenance Upgrade	FY 25 - FY35	29,000,000	2,000,000	3,000,000	3,000,000	3,000,000	3,000,000	3,000,000	3,000,000	3,000,000	3,000,000	3,000,000
Subtotal		\$325,731,000	\$44,000,000	\$53,900,000	\$56,000,000	\$ 76,500,000	\$ 66,500,000	\$ 6,500,000	\$ 5,000,000	\$ 5,777,000	\$ 5,777,000	\$ 5,777,000
SEWER PROJECTS:												
Pye Branch Gravity Sewer Rehabilitation	FY 29 - FY 30	\$ 4,000,000	\$ -	\$ -	\$ -	\$ -	\$ 2,000,000	\$ 2,000,000	\$ -	\$ -	\$ -	\$ -
Oakland Avenue/CSX/McLeod Sewer Rehabilitation	FY 29 - FY30	2,500,000	-	-	-	-	1,250,000	1,250,000	-	-	-	-
West Darlington Street Sewer Rehabilitation	FY 28	1,000,000	-	-	-	1,000,000	-	-	-	-	-	-
Police Cabin Lift Station	FY 26 - FY 27	6,000,000	-	3,000,000	3,000,000	-	-	-	-	-	-	-
Middle Swamp Interceptor	FY 30 - FY 35	5,000,000	-	-	-	-	-	1,000,000	1,000,000	1,000,000	1,000,000	1,000,000
Woody Jones - Hoffmeyer Road Sewer	FY 26 - FY 27	4,000,000	-	2,000,000	2,000,000	-	-	-	-	-	-	-
WWMF	FY 29 - FY 33	250,000,000	-	-	-	-	40,000,000	55,000,000	55,000,000	50,000,000	50,000,000	-
Jeffries Creek Interceptor Upgrade and Maintenance Rehabilitation	FY 25 - FY 28	45,000,000	500,000	15,000,000	15,000,000	14,500,000	-	-	-	-	-	-
East Palmetto Corridor	Economic Development Driven	-	-	-	-	-	-	-	-	-	-	-
Timmonsville - Florence Interceptor	FY 28 - FY 30	33,000,000	-	-	-	11,000,000	11,000,000	11,000,000	-	-	-	-
Subtotal		\$350,500,000	\$ 500,000	\$20,000,000	\$20,000,000	\$ 26,500,000	\$ 54,250,000	\$ 70,250,000	\$ 56,000,000	\$ 51,000,000	\$ 51,000,000	\$ 1,000,000
TOTAL WATER & SEWER		\$676,231,000	\$44,500,000	\$73,900,000	\$76,000,000	\$ 103,000,000	\$ 120,750,000	\$ 76,750,000	\$ 61,000,000	\$ 56,777,000	\$ 56,777,000	\$ 6,777,000

First Tryon Advisors

SIMPLIFYING PUBLIC FINANCE

WWW.FIRSTTRYON.COM

MSRB Registrant

DISCLAIMER: This communication was prepared by First Tryon Advisors, LLC ("First Tryon Advisors") and is for informational purposes only and should not be construed as an offer or solicitation to sell or buy any securities. This material does not provide tax, regulatory, accounting, or legal advice. Prior to entering into any proposed transaction, recipients should determine, in consultation with their own investment, legal, tax, regulatory and accounting advisors, the economic risks and merits, as well as the legal, tax, regulatory, and accounting characteristics and consequences, of the proposed transaction.

Any proposal included in this communication is confidential information of First Tryon Advisors and is solely for the benefit of the recipient(s), and the recipient(s) is (are) not authorized to sell, redistribute, forward or deliver this communication to any other person without the prior written consent of First Tryon Advisors.

The statements within this material constitute the views, perspective and judgment of First Tryon Advisors at the time of distribution and are subject to change without notice. First Tryon Advisors gathers its data from sources it considers reliable; however, it does not guarantee the accuracy or completeness of the information provided within this communication. The material presented reflects information known to First Tryon Advisors at the time this communication was prepared, and this information is subject to change without notice. First Tryon Advisors makes no warranties regarding the accuracy of this material.

Any forecasts, projections, or predictions of the market, the economy, economic trends, and equity or fixed-income markets are based upon current opinion as of the date of issue, and are also subject to change. Opinions and data presented are not necessarily indicative of future events or expected performance. Actual events may differ from those assumed and changes to any assumptions may have a material impact on any projections or performance. Other events not taken into account may occur and may significantly affect the projections or estimates. Certain assumptions may have been made for modeling purposes only to simplify the presentation and/or calculation of any projections or estimates, and First Tryon Advisors does not represent that any such assumptions will reflect actual future events. Accordingly, there can be no assurance that estimated projections will be realized or that actual performance results will not materially differ from those estimated herein.

First Tryon Advisors is registered as a municipal advisor with the Securities and Exchange Commission ("SEC") and the Municipal Securities Rulemaking Board ("MSRB"). Neither the SEC, MSRB, nor any other regulatory organization endorses, indemnifies, or guarantees First Tryon Advisors' business practices or selling methods.

FLORENCE CITY COUNCIL MEETING

DATE: August 12, 2024

AGENDA ITEM: Ordinance to Annex and Zone Phase II of Smith's Field, TMNs 00100-01-337 through -380, previously a portion of TMN 00100-01-093.

DEPARTMENT/DIVISION: Department of Planning, Research & Development

I. ISSUE UNDER CONSIDERATION:

A request to annex Tax Map Numbers 00100-01-337 through 00100-01-380 inclusive into the City of Florence and assign them the zoning designation of RG-3 (Residential General-3). The request is being made by the property owner.

II. CURRENT STATUS/PREVIOUS ACTION TAKEN:

On July 9, 2024, the Planning Commission held a public hearing regarding the annexation of these lots and voted unanimously, 6-0, to recommend the zoning designation of RG-3.

III. POINTS TO CONSIDER:

- (1) This request is being considered for first reading.
- (2) The property is being developed as a single family residential subdivision.
- (3) Phase I was annexed on May 8, 2023.
- (4) This is Phase II of three total phases.
- (5) City water and sewer services are being installed by the developer.
- (6) The development agreement approved by City Council in April, 2023, establishes that the properties are to be zoned RG-3 at the time of annexation.

IV. PERSONAL NOTES:

V. ATTACHMENTS:

- (1) Ordinance
- (2) Vicinity Map
- (3) Phase Map
- (4) Annexation Petition

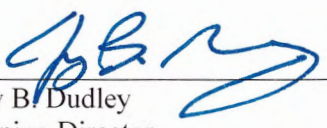
Jerry B. Dudley
Planning Director

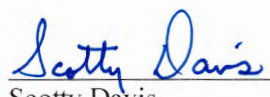
Scotty Davis
City Manager

ORDINANCE NO. 2024-_____

AN ORDINANCE TO ANNEX AND ZONE RG-3 PHASE II OF SMITH'S FIELD, TMNs 00100-01-337 THROUGH -380.

WHEREAS, a Public Hearing was held in Council Chambers on July 9, 2024 at 6:00 P.M. before the City of Florence Planning Commission, and notice of said hearing was duly given;

WHEREAS, application by Highgate LLC, owner of TMNs 00100-01-337 through -380, was presented requesting an amendment to the City of Florence Zoning Atlas that the indicated properties be incorporated into the City limits of the City of Florence under the provisions of Section 5-3-150(3) of the 1976 Code of Laws of South Carolina and given the zoning district classification of **RG-3**.

The properties requesting annexation are shown more specifically below:

Tax Map Number	Area (Acre)	Street Address
00100-01- 337	0.1646	2943 Suzanne Dr.
00100-01- 338	0.1716	2939 Suzanne Dr.
00100-01- 339	0.1716	2935 Suzanne Dr.
00100-01- 340	0.1716	2931 Suzanne Dr.
00100-01- 341	0.1716	2927 Suzanne Dr.
00100-01- 342	0.1716	2923 Suzanne Dr.
00100-01- 343	0.1716	2919 Suzanne Dr.
00100-01- 344	0.1716	2915 Suzanne Dr.
00100-01- 345	0.2559	2911 Suzanne Dr.
00100-01- 346	0.2863	2907 Suzanne Dr.
00100-01- 347	0.1934	835 Sharpe Dr.
00100-01- 348	0.1716	831 Sharpe Dr.
00100-01- 349	0.217	827 Sharpe Dr.
00100-01- 350	0.18	2902 Fincher Dr.
00100-01- 351	0.2046	2903 Fincher Dr.
00100-01- 352	0.4566	804 Sharpe Dr.
00100-01- 353	0.387	808 Sharpe Dr.
00100-01- 354	0.3203	812 Sharpe Dr.
00100-01- 355	0.3349	816 Sharpe Dr.
00100-01- 356	0.2087	820 Sharpe Dr.
00100-01- 357	0.1895	824 Sharpe Dr.
00100-01- 358	0.189	828 Sharpe Dr.
00100-01- 359	0.1884	832 Sharpe Dr.
00100-01- 360	0.1879	836 Sharpe Dr.
00100-01- 361	0.1873	840 Sharpe Dr.

EXECUTED ON ONE (1) ADDITIONAL PAGE

Tax Map Number	Area (Acre)	Street Address
00100-01- 362	0.2182	844 Sharpe Dr.
00100-01- 363	0.1904	848 Sharpe Dr.
00100-01- 364	0.1852	852 Sharpe Dr.
00100-01- 365	0.1747	856 Sharpe Dr.
00100-01- 366	0.4324	860 Sharpe Dr.
00100-01- 367	0.2793	864 Sharpe Dr.
00100-01- 368	0.2571	859 Sharpe Dr.
00100-01- 369	0.1489	855 Sharpe Dr.
00100-01- 370	0.1637	851 Sharpe Dr.
00100-01- 371	0.2324	847 Sharpe Dr.
00100-01- 372	0.15	2910 Suzanne Dr.
00100-01- 373	0.1708	2914 Suzanne Dr.
00100-01- 374	0.1716	2918 Suzanne Dr.
00100-01- 375	0.1716	2922 Suzanne Dr.
00100-01- 376	0.1716	2926 Suzanne Dr.
00100-01- 377	0.1716	2930 Suzanne Dr.
00100-01- 378	0.1716	2934 Suzanne Dr.
00100-01- 379	0.1716	2938 Suzanne Dr.
00100-01- 380	0.1651	2942 Suzanne Dr.

Any portions of public rights-of-way abutting the properties listed above are included in the annexation.

WHEREAS, Florence City Council concurs in the aforesaid application, findings and recommendations:

NOW, THEREFORE BE IT ORDAINED BY THE CITY COUNCIL OF THE CITY OF FLORENCE IN MEETING DULY ASSEMBLED AND BY THE AUTHORITY THEREOF:

1. That an Ordinance is hereby adopted annexing into the City Limits of the City of Florence the aforesaid properties and amending the Zoning Atlas to the aforesaid zoning classifications.
2. That this Ordinance shall become effective seven days upon its approval and adoption by the City Council of the City of Florence and posting of this amendment in the official Zoning Atlas.

EXECUTED ON ONE (1) ADDITIONAL PAGE

ADOPTED THIS _____ DAY OF _____, 2024

Approved as to form:

Benjamin T. Zeigler
City Attorney

Teresa Myers Ervin,
Mayor

Attest:

Casey C. Moore
Municipal Clerk

PC 2024-18

Vicinity Map - Smith's Field Phase II

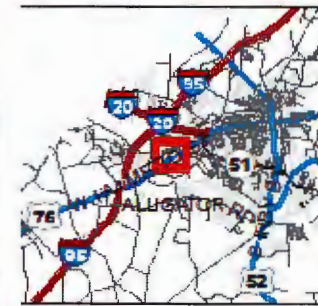

Legend

- City Limits
- Parcels
- Proposed Parcel



DISCLAIMER:
The City of Florence Department of Planning, Research, and Development data represented on this map is the product of computerization, as produced by GIS. It is provided for informational purposes only and the City of Florence makes no representation as to its accuracy. Its use without field verification is at the sole risk of the user.

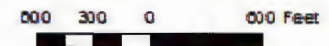

Date: 6/5/2024

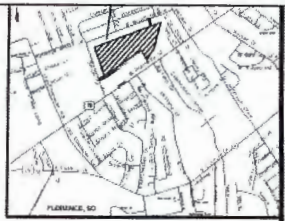
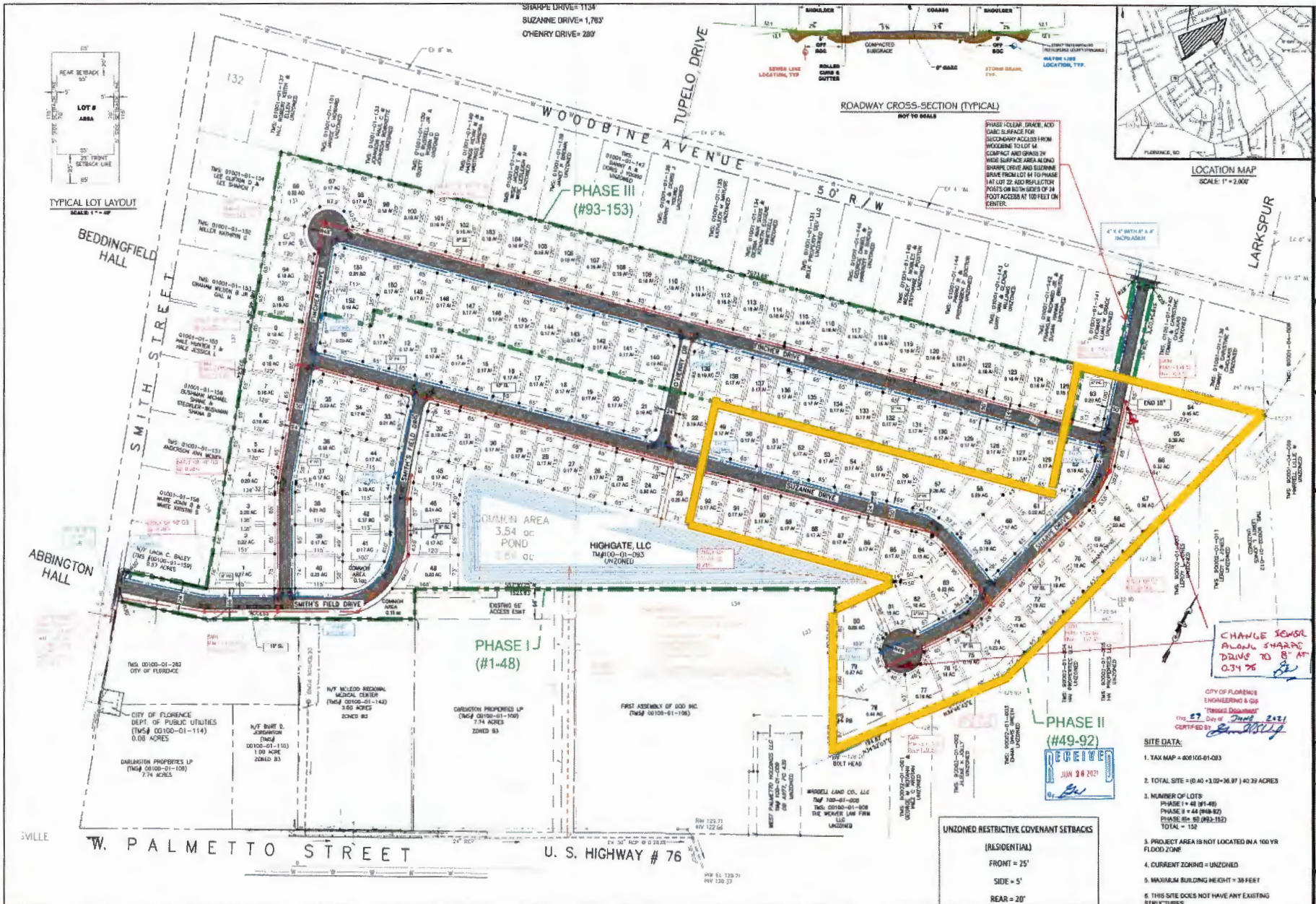

TYPICAL LOT LAYOUT
SCALE 1" = 10'

ROADWAY CROSS-SECTION (TYPICAL)
NOT TO SCALE

LOCATION MAP
SCALE: 1" = 2,000'

PHASE II LANE, GRADE AND CURB SURFACE FOR SUCCESSFUL ACCESS FROM WOODBINE TO LOT 14. COMPACT AND GRASS IN THIS SURFACE AREA ALONG SHARPE DRIVE AND SUZANNE DRIVE FROM LOT 14 TO PHASE II AT LOT 22. ADD REFLECTOR POSTS OR 80 TH SIZE OF 24 FOOT ACCESS AT 10 FEET ON CENTER.

CHANGE SEWER ALONG SHARPE DRIVE TO 8" AT 0.34 26

PHASE II (#49-92)
RECEIVED
JUN 28 2021

UNZONED RESTRICTIVE COVENANT SETBACKS
(RESIDENTIAL)
FRONT = 25'
SIDE = 5'
REAR = 20'

- SITE DATA:
- TAX MAP = 400100-01-033
 - TOTAL SITE = (0.40 + 1.02 + 36.97) = 38.39 ACRES
 - NUMBER OF LOTS:
PHASE I = 48 (#1-48)
PHASE II = 44 (#49-92)
PHASE III = 60 (#93-153)
TOTAL = 152
 - PROJECT AREA IS NOT LOCATED IN A 100 YR FLOOD ZONE
 - CURRENT ZONING = UNZONED
 - MAXIMUM BUILDING HEIGHT = 38 FEET
 - THIS SITE DOES NOT HAVE ANY EXISTING SETBACKS

NO. 1	DATE	PLAN SET REVISION DESCRIPTION
1		ISSUED FOR PERMIT
<p>DESIGNED BY: [Signature]</p> <p>CHECKED BY: [Signature]</p> <p>DATE: [Date]</p> <p>PROJECT: SMITH'S FIELD FLORENCE, SC</p> <p>CLIENT: HIGHGATE, ILLC.</p>		
<p>DESCRIPTION: SKETCH PLAN</p>		
<p>PROHIBITED: THIS DRAWING IS THE PROPERTY OF ROBERT L. WEAVER, P.E. NO PART OF THIS DRAWING IS TO BE REPRODUCED OR TRANSMITTED IN ANY FORM OR BY ANY MEANS WITHOUT THE WRITTEN PERMISSION OF ROBERT L. WEAVER, P.E.</p>		
<p>ENGINEER: ROBERT L. WEAVER, P.E. CITY ENGINEER AND LAND PLANNING FLORENCE, SC 29501 PHONE: 803 344 2200 FAX: 803 344 2200 www.rlw.com</p>		
<p>DESCRIPTION: SKETCH PLAN</p>		

Phase 2: Lots #49 to 92

STATE OF SOUTH CAROLINA)

PETITION FOR ANNEXATION

COUNTY OF FLORENCE)

Petition requesting Florence City Council to enact an Ordinance annexing the area described below, that area being the same property as shown by the map prepared by the City of Florence Planning, Research, and Development Department, attached and incorporated by reference herein:

The undersigned freeholder property owner(s) hereby respectfully certifies, petitions, and requests of the City Council of Florence as follows:

1. The petitioners are the sole owner(s) of real estate in the County of Florence, State of South Carolina which property lies adjacent and contiguous to the corporate limits of the City of Florence.
2. That the petitioner(s) desires to annex the property more particularly described below:
 Florence County Tax Map Number: 00100-01-093 (portion)
3. Annexation is being sought for the following purposes: City services
4. That the petitioner(s) request that the City Council of Florence annex the above described property in accordance with subsection 31 of 5-3-150(3) of the Code of Laws of South Carolina for 1976, such section allowing the annexation of an area without the necessity of an election and referendum.

To the Petitioner: The following information needs to be completed for submittal to the City of Florence and other government agencies for records prior to and after annexation.

Total Residents _____ Race _____
 Total 18 and Over _____ Total Registered to Vote _____

APPLICANT (S) (Please print or type):

Name(s): HighCafe LLC (John C Curl)
 Address: PO Box 4815 Florence, SC 29502
 Telephone Numbers: 843 669 2305 [work] 843 687 1313 [home] Cell
 Email Address: curljohn@outlook.com

Signature John C Curl Date 6/5/24

Certification as to ownership on the date of petition:	FOR OFFICAL USE ONLY
Date <u>6/5/24</u>	<u>az</u>

FLORENCE CITY COUNCIL MEETING

DATE: August 12, 2024

AGENDA ITEM: An Ordinance to annex and zone Commercial General (CG) 525 South Ebenezer Road, TMN 00074-01-334.

DEPARTMENT/DIVISION: Department of Planning, Research & Development

I. ISSUE UNDER CONSIDERATION:

Request to annex property located at 525 South Ebenezer Road, Tax Map Number 00074-01-334, into the City of Florence and assign it the zoning designation of Commercial General (CG). The request is being made by the property owner.

II. CURRENT STATUS/PREVIOUS ACTION TAKEN:

On July 9, 2024, the City of Florence Planning Commission held a public hearing on this matter, and voted unanimously, 6-0, to recommend the zoning request of Commercial General.

III. POINTS TO CONSIDER:

- (1) City water and sewer services are currently available; there is no cost to extend utilities.
- (2) A Public Hearing for zoning was held at the July 9, 2024 Planning Commission meeting.
- (3) City staff recommends annexation and concurs with Planning Commission's recommendation to zone the property Commercial General.

IV. PERSONAL NOTES:

V. ATTACHMENTS:

- (1) Ordinance
- (2) Vicinity Map
- (3) Annexation Petition



Jerry B. Dudley
Planning Director

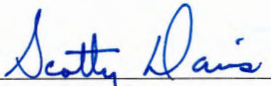

Scotty Davis
City Manager

ORDINANCE NO. 2024 - _____

**AN ORDINANCE TO ANNEX AND ZONE COMMERCIAL GENERAL
525 SOUTH EBENEZER ROAD, TMN 00074-01-334.**

WHEREAS, a Public Hearing was held in the Council Chambers on July 9, 2024 at 6:00 P.M. before the City of Florence Planning Commission, and notice of said hearing was duly given;

WHEREAS, application by MDI Management LLC, owner of TMN 00074-01-334, was presented requesting an amendment to the City of Florence Zoning Atlas that the aforesaid property be incorporated into the City limits of the City of Florence under the provisions of Section 5-3-150(3) of the 1976 Code of Laws of South Carolina and given the zoning district classification of **CG**:

The property requesting annexation is shown more specifically on Florence County Tax Map 00074, block 01, parcel 334 (10.297514 acres).

Any portions of public rights-of-way abutting the property described above will be included in the annexation.

WHEREAS, Florence City Council concurs in the aforesaid application, findings, and recommendations:

NOW, THEREFORE BE IT ORDAINED BY THE CITY COUNCIL OF THE CITY OF FLORENCE IN MEETING DULY ASSEMBLED AND BY THE AUTHORITY THEREOF:

1. That an Ordinance is hereby adopted annexing into the City Limits of the City of Florence the aforesaid property and amending the Zoning Atlas to the aforesaid zoning classifications.
2. That this Ordinance shall become effective in seven days upon its approval and adoption by the City Council of the City of Florence and posting of this amendment in the official Zoning Atlas.

ADOPTED THIS _____ DAY OF _____, 2024

Approved as to form:

Benjamin T. Zeigler,
City Attorney

Teresa Myers Ervin,
Mayor



Attest:

Casey C. Moore,
Municipal Clerk

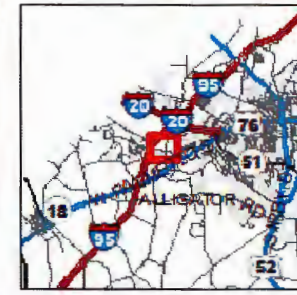
PC 2024-19
Vicinity Map - 525 S. Ebenezer Rd.



Legend

-  City Limits
-  Parcels
-  Proposed Parcel



DISCLAIMER:
 The City of Florence Department of Planning, Research, and Development data represented on this map is the product of compilation, as produced by others. It is provided for informational purposes only and the City of Florence makes no representation as to its accuracy. It is without field verification and is at the sole risk of the user.

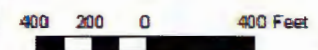

6/20/2024

STATE OF SOUTH CAROLINA)

PETITION FOR ANNEXATION

COUNTY OF FLORENCE)

Petition requesting Florence City Council to enact an Ordinance annexing the area described below, that area being the same property as shown by the map prepared by the City of Florence Planning, Research, and Development Department, attached and incorporated by reference herein:

The undersigned freeholder property owner(s) hereby respectfully certifies, petitions, and requests of the City Council of Florence as follows:

- 1. The petitioners are the sole owner(s) of real estate in the County of Florence, State of South Carolina which property lies adjacent and contiguous to the corporate limits of the City of Florence.
- 2. That the petitioner(s) desires to annex the property more particularly described below:
 Florence County Tax Map Number: 00074-01-334
- 3. Annexation is being sought for the following purposes:
- 4. That the petitioner(s) request that the City Council of Florence annex the above described property in accordance with subsection 31 of 5-3-150(3) of the Code of Laws of South Carolina for 1976, such section allowing the annexation of an area without the necessity of an election and referendum.

To the Petitioner: The following information needs to be completed for submittal to the City of Florence and other government agencies for records prior to and after annexation.

Total Residents X Race X
 Total 18 and Over X Total Registered to Vote X

APPLICANT (S) (Please print or type):

Name(s): MDI Management, LLC
 Address: 120 Fourth St. SW Hickory, NC 28102
 Telephone Numbers: 828 725 4838 [work] _____ [home]
 Email Address: Kathleen.perkins@alexlee.com

Signature John B. Engain Date 5/29/24

Certification as to ownership on the date of petition:	FOR OFFICAL USE ONLY
Date <u>6/6/24</u>	<u>AB</u>